

05/2022

VMA VERLAG  
Cologne /Germany



# EXTRUSION INTERNATIONAL

USA

CHOOSE  
THE FUTURE  
FOR YOUR  
CHILDREN



curious?



visit us at Stand 9B35



**FIMIC**  
ITALIAN.MELT.FILTER

www.fimic.it

## Stein Profile Stacker

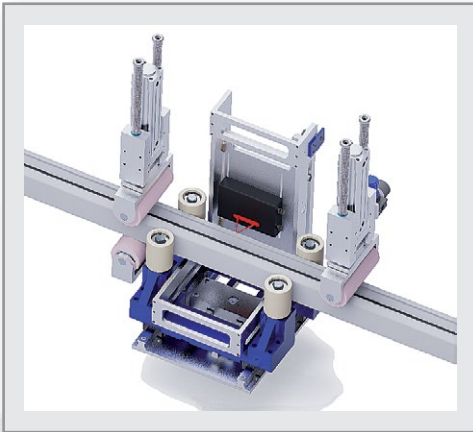

### Profile length measurement during extrusion

Measuring sensors are used to determine the length of individual profiles before a profile layer is formed.

The measured length can be used to check and correct the cutting device of the extrusion line or for documentation (quality assurance) of the produced profile lengths.

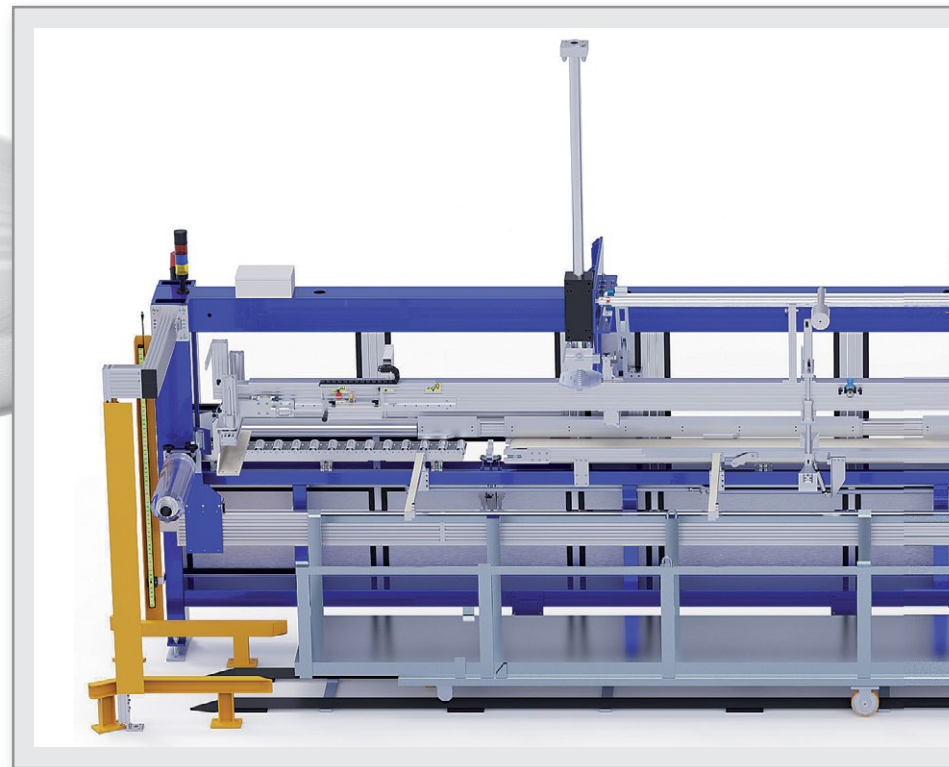
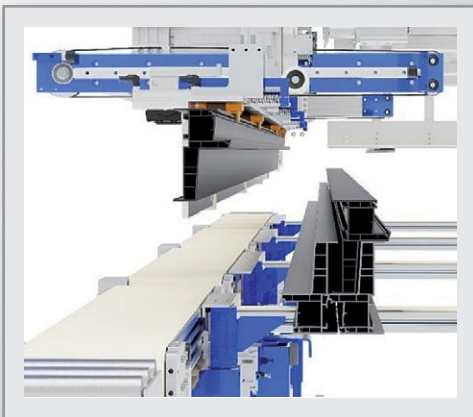

### Stacking of special profiles

Stein Maschinenbau offers technical solutions for stacking of heavy and large monoblock profiles.

Based on decades of experience, we can unusual profile geometries or special layer can be evaluated for their automated stacking.



### Cassette spreader

With the help of a cassette spreader it is possible to realise the same packing density of the manual packaging.



Made in  
Germany



19 - 26. 10. 2022  
Düsseldorf, Germany  
Hall 16, Stand F 15



## Stein Profile Stacker



### Weight determination during extrusion

With the help of special weighing units, individual profiles can be weighed before a profile layer is formed. The determined weight can be used to optimise the extrusion.

As a specialist in the field of special machine construction, we always find a solution!



### Cassette handling

The handling system allows empty cassettes to be fed into the automatic stacker and the filled cassettes to be pushed out.

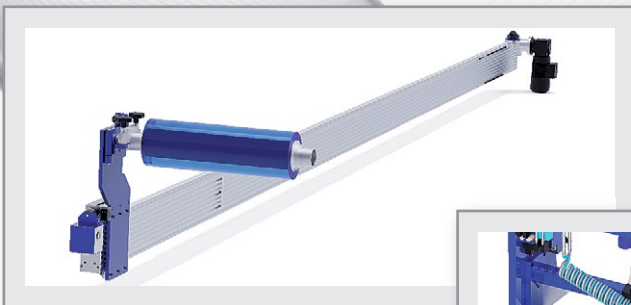

### Profile interlayer

Endlessly laid as a foil between the profile layers or with individual strips laid on the layer.

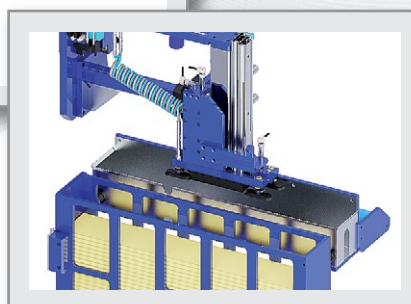

**STEIN Maschinenbau  
GmbH & Co. KG**

Wartbachstrasse 9  
66999 Hinterweidenthal/Germany  
Tel. (+49) (0)63 96-9215-0  
Fax (+49) (0)63 96-9215-25  
stein@stein-maschinenbau.de  
www.stein-maschinenbau.de

## MEDICAL TUBING EXTRUSION LINES

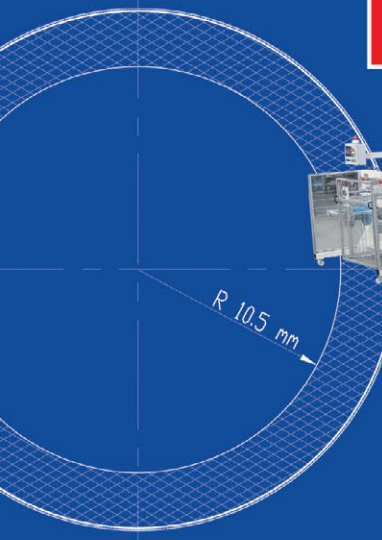
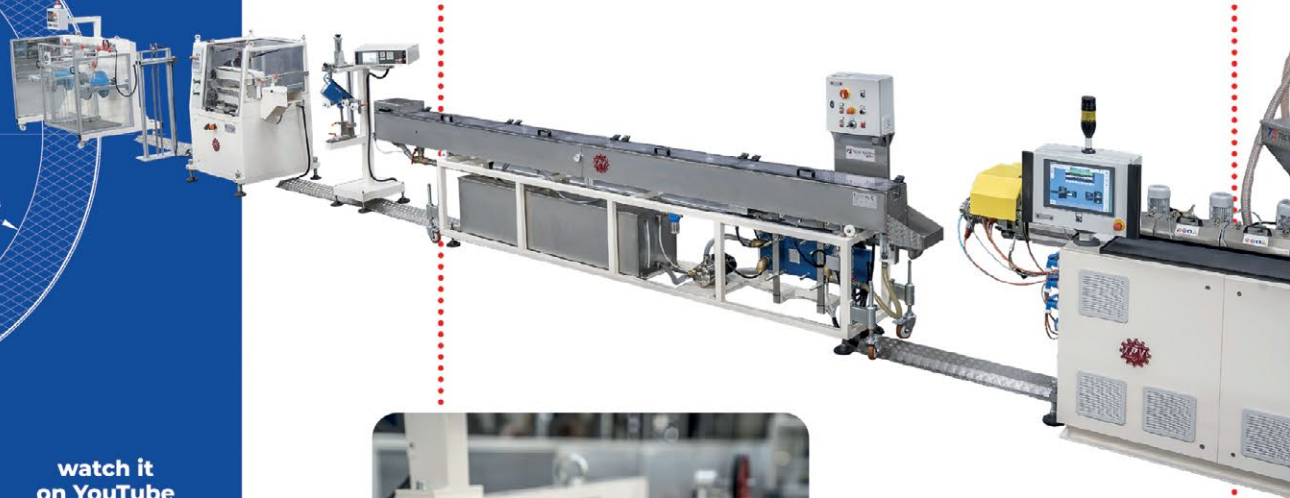

watch it  
on YouTube



These lines are suitable for smoothbore tubes with rigid or semi-rigid spiral also combining different polymers. Lines can be customized with special stainless steel water tank, special drying system, dedicated chiller and close-loop water circuit to prevent contamination. Lines are equipped with high-speed cutting units with discharge table.





Via Rosa Bardelli 2/B, 44011 Consandolo (FE) - Italy  
Tel. (+39) 0532 858 883/666 • Fax (+39) 0532 859 098  
[commerciale@tecnosystemfe.it](mailto:commerciale@tecnosystemfe.it)

**tecnosystemfe.it**

Our medical extrusion lines comply any stringent law about products and processes in medical tubing sector. Lines, completely customizable, can produce from single to multi-layer and radiopaque tubes in many different medical materials and are equipped with the most efficient dimensional and retroactive control systems to achieve the most accurate reports about dimensions and diameters of tubes.



## SPIRAL SMOOTHBORE MEDICAL PIPES EXTRUSION LINES

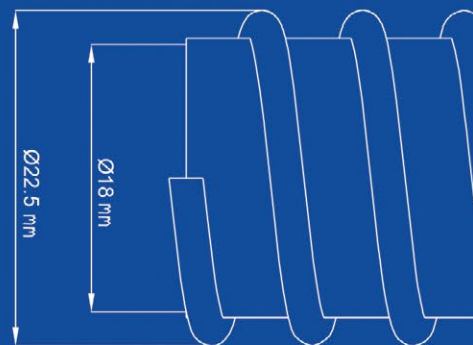
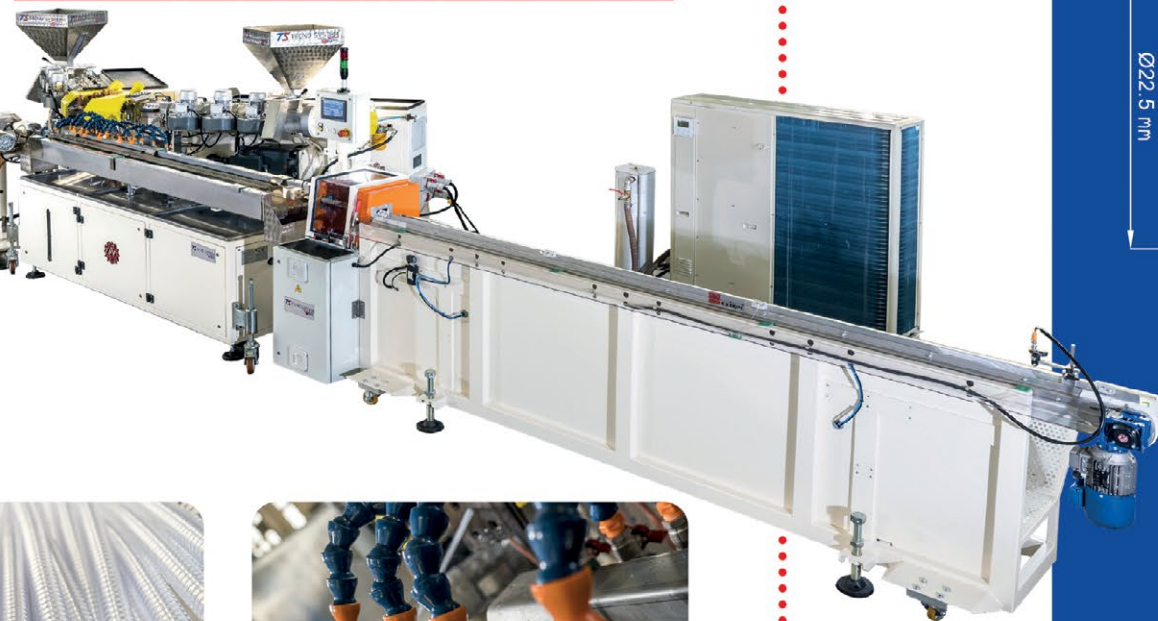

watch it  
on YouTube



Firms in this issue	6	A First Glimpse of the Topics, Activities and Highlights Provided at K 2022	42
Imprint	7	Innovative Series With More Than 12 New Machine Sizes	44
<b>Industry News</b>	8	Highlights and Innovations at K 2022	45
Calendar	8	Modular Automation Concept	46
German Plastics and Rubber Machinery Industry Currently Facing Major Challenges After a Good Previous Year	8	New Brand Advances the Circular Economy by Enabling Use of More Recycled Materials in End-Use Applications	47
NPE2024: The Plastics Show – Planning Team	9	„Inspire Beyond Measurement“	48
New Carbon Reduced Masterbatch	9	Innovative Degassing and Decontamination Technologies for Demanding Recycling Applications	50
Portfolio of Circular Base Chemicals Introduced	10	Measuring Technology: Innovative Technologies for a Sustainable Future	52
Two New License and Engineering Agreements for Confidential Client Signed	12	Shredding Solutions for Post-Consumer Plastic Recycling	55
Distribution Agreement for Brazil Signed	12	Intelligent & Smart Product Solutions for Inspection, Analysis and Classification of Gels & Contaminations	56
Successfully Certified	12	Two Innovations for the Circular Economy Live at the Booth	58
Packaging Made from Post-Consumer Recycled and Biomass Balanced Materials	13	Masterbatch and Compound Solutions	59
Facilitate the Use of Recycled Plastics	14	New Lines for Single and Double Output Pipes Offering Enhanced Performance	60
New Construction of State-Of-The-Art Test Lab for Plastics Recycling Applications	14	Less Energy, Less Material and Circularity for the Packaging and Carpet Industries	62
Portfolio with Catalysts and Absorbents for Plastics Recycling Introduced	16	High-Efficiency Technologies for the Processing and Recycling Plastics	63
Reclassification of Recyclability of Coextruded Polyethylene/Polyamide Film Structures	16	Technical Solution to One of the Biggest Challenges in the Processing of Recyclate	66
New Publication Grants Insight Into the Mechanical Recycling of PE/PA Multilayer Films	16	Sustainability Strategies for Packaging Stakeholders	68
Market Study: Plastic Pipes	17	New Anti-Fouling Additive for the PP and PE Polymerisation Process	69
New Chief Financial Officer	17	Efficient All-In-One Plastics Recycling Solutions	70
Certification Scheme for Plastics Recyclers Published	18	Weigh Scale Blenders (WSB) Series Added	71
New Flame Retardant Masterbatch Made of Post-Consumer Recycled Polypropylene	18	Leading Plastics Recycling Towards a Circular Economy	72
Used Machinery Trading with a Positive Contribution to the CO <sub>2</sub> Balance	19	Plastics Shredding Gets Even Smarter	73
New Technical Manager	20	Circularity Through Plastics Additives in the Spotlight	74
Reciprocating Head Introduced	20	Circular Economy and Sustainability	75
New Choices of Gravimetric Feeders	22	Expanded Product Portfolio and Material Supply Capabilities at K 2022	76
Quadruple Extrusion Line for PVC-U Pipes	23	Sustainable and Efficient Drive Concepts for the Plastics Industry	76
Expanded Line of Compostable Resins for Packaging and Single-Use Applications Launched	24	<b>Recycling – Case Study</b>	
PPS Delivers Increase Transmittance and Toughness in Laser Welding Applications	24	Recycling Pioneer Establishes Closed Loop for PET Food Packaging	78
Circular Economy Packaging	26	<b>Recycling</b>	
New Multi-Purpose TPV with 25% Recycled Content	27	Customized Recycling Machines for the Sustainable Processing of Plastic Waste	80
Agreement on the Production and Procurement of Pyrolysis Oil from Mixed Plastic Waste	28	<b>Recycling – Case Study</b>	
Market Study: Plastics	28	Company Foundation – With German Machines Into The Recycling Future	82
Industry News USA	30	<b>Material Handling</b>	
Agreement on the Production and Procurement of Polyrolysis Oil from Mixed Plastic Waste	30	Global Approach, Italian Roots	83
Investment in Indiana Recycling Expansion	31	<b>Measuring and Control Technology</b>	
„MEDD“ical Extrusion Aids Impossible	32	A Success Story – 50 Years of KÜNDIG CONTROL SYSTEMS	84
Production at World-Class Clarifier Plant Launched	32	<b>Hose Production Heads</b>	
Plastics Industry Association Bioplastics Innovation Award	33	Smart, Economical, and Sustainable Hose Manufacture	86
New Member of Moard of Directors	34	<b>Film Extrusion</b>	
Vice President, Treasury and Finance Appointed	34	Turnkey Extrusion Line for Encapsulation Film for PV Modules	88
Additional \$500 Million for Share Repurchase Program Authorized	34	Automation	
Clean-Up Event	35	Quality is our Priority	89
Global Sustainability Initiative Launched	35	<b>Processing</b>	
2022 Size and Impact Report: PLASTICS Moves to America's 6th Largest Manufacturing Industry	36	Compounding of Recycling Plastics Opens Up New Opportunities	90
New Nofia® FR Grade Introduced	36	<b>Pipe Extrusion</b>	
<b>K 2022</b>		The Largest PVC-O Pipe in the World – Molecor at K 2022	92
Official Special Show „Plastics Shape the Future“ Focuses on the Hot Topics Climate Protection, Circular Economy and Digitalization	38	<b>Plasma Technologies – From the Research</b>	
Plastics Expertise and Innovative PET Recycling for High-Quality Products	38	Recyclable Barrier Systems for Sustainable Packaging	94
Successful Extruder Now Also Available in Size 45	40	<b>Recycling</b>	
Pulsation-Free Passage Through the PVC Die	40	Closing the Plastic Cycle	96
Cutting-Edge Solutions in Rubber and Plastics Processing	41	<b>Pelletizing</b>	
		Energy-Saving Solution for Pelletizing of rPET/PET	98





78

As a plastic packaging manufacturer and EREMA customer in Denmark, Faerch is the first company in the world to successfully integrate the recycling of european post-consumer PET household pots, tubs and tray packaging into its own production process



80

For 25 years now, NGR has been one of the pioneers in the field of sustainable plastics recycling. The company develops and builds customized recycling machines for the sustainable processing of plastic waste



83

Subject-matter expertise, competence and innovation are the pillars that have guided the Moretto business for over 40 years in pursuing a fundamental goal: to satisfy customer requests, to exceed expectations, to be the ideal partner in the supply of automations for the plastics processing industry



88

BREYER's extrusion system "CellProtect" allows the production of low shrinkage EVA and POE encapsulation film at high production speed – Another benefit – no energy consuming annealing and no interlayer film makes the production economic and energy saving

As a market-leading company for adjustable calibration sleeves, CCA cares for the automation of plastic pipe production with long-term experience and know-how



89

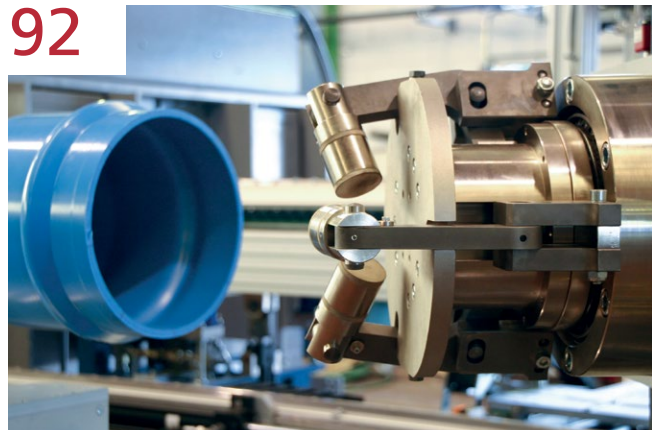

92

Molecor will be present at K 2022 with its latest innovations. Among them the DN1200 mm PVC-O pipe, the largest in the world and only manufactured by Molecor

## Index of Advertisers, companies and *fairs* referred in this issue

<b>A</b> ddex	30	Gamma Meccanica	25	Nordson	34
Avient	14	GINDUMAC	19	Novolex	31
<b>B</b> ASF	16, 28	Gneuss	50	<b>O</b> CS	56
battenfeld-cincinnati	40, 59	Green Dot Bioplastics	24	OMV Technologies	68
Baumüller	76	Guill Tool	17, 20, 31	<b>P</b> alsgaard	69
BB Engineering	38	<b>H</b> ellweg Maschinenbau	73	Pixargus	39
Bausano	60	Herbold Meckesheim	45, 82	Plas Mec	11
Beier	27	Hillesheim	19	PLASTICS	9, 31, 33, 35, 36
Bekum	44, 55	<b>I</b> KV-Aachen	74	Polyplastics	24, 76
BHS-Sonthofen	96	iNOEX	21, 48	Promix	45
BIO-FED	12	<b>K</b> 2022	30	<b>R</b> ecyClass	18
Borealis	10, 42	Kampf	61	Reifenhäuser	66
Brabender	75	Kautex	71	<b>S</b> ICA	23
Breyer	88	KIEFEL	46	SI Group	47
Brückner	49	KraussMaffei	58	Sikora	52, 67
BUSS	65	KÜNDIG	43, 84	Smart-Extrusion	37, Inside Back Cover
<b>C</b> CA	13, 89	<b>L</b> ab-Conference	Outside Back Cover	SML	41
Ceresana	17, 28	Lindner-Recyclingtech	70	Starlinger	73
Coperion	14, 29, 63	<b>M</b> AAG	77, 90	Stein Maschinenbau	Inside Front Cover+3
<b>D</b> avis-Standard	17, 32, 35, 51	Maguire	22, 71	<b>T</b> aitra	57
<b>E</b> CI	10	Meaf	62	Teknor Apex	27
Econ	98	Messe Düsseldorf	38	TOMRA	26
ENTEX	61	Milliken	32, 74	Troester	41, 86
EREMA	42, 53, 78	Modern Dispersions	59	<b>V</b> DMA	8
Erge	47	Molecor	63, 92	Viscotec	73
<b>F</b> aerch	78	Mondi	13	<b>W</b> EIMA	55
Feddersen	12	Moretto	83	Zumbach	15
FIMIC	Outside Cover, 72	motan-colortronic	7		
FRX	36	<b>N</b> anjing Lexun	23		
<b>G</b> abriel-Chemie	9, 18	NGR	20, 80		



## Follow the news in the world of extrusion!

Subscribe to digital magazines  
and Smart Extrusion weekly newsletter

- **Just** submit your **e-mail address**.
- Digital magazines and news updates **free of charge**
- No spam. Your data is safe



[www.extrusion-info.com/subscription](http://www.extrusion-info.com/subscription)





The Extrusion International Magazine  
is published bimonthly by VM Verlag GmbH.  
P.O.Box 501812, D- 50879 Cologne, Germany

**EDITORS**

Bettina Jopp-Witt (Editor-in-chief)  
Tel. +49 221 546 1539  
redaktion@vm-verlag.com

Dmitry Kosuch  
Tel. +7 996 730 0113  
d.kosuch@vm-verlag.com

**ADVERTISING SALES**

Martina Lerner  
Tel.+49 6226 971515  
lerner-media@t-online.de

Bella Eidlin  
Tel. +49 152 29907895  
b.eidlin@vm-verlag.com

Olga Kirchner  
Tel. +49 152 05626122  
o.kirchner@vm-verlag.com

**ADMINISTRATION**

Alla Kravets  
Tel. +49 2233 949 8793  
a.kravets@vm-verlag.com

**PRINTING**

maincontor GmbH  
Dr.-Gammert-Str. 13a, 63906 Erlenbach, Germany  
T.: +49 937294810811  
www.maincontor.de, info@frankhohmann.com

**SALES REPRESENTATIVES**

Quaini Pubblicita (Milano IT)  
Tel. +39 02 39216180  
info@quaini-pubblicita.it

China & Asia  
octavia@ringier.com.hk, Tel. +852-9648-2561  
maggieliu@ringiertrade.com, Tel. +86-13602785446

Tokyo PR Inc. (Japan)  
Tel. +81 (3) 3273-2731  
extrusion@tokyopr.co.jp

**Reprints, Translation etc**

No part of this publication may be reproduced, stored  
in a retrieval system, or transmitted, in any form or  
by any means, electronic, mechanical, photographic,  
recording or otherwise, without prior permission of  
the publisher.

[www.smart-extrusion.com](http://www.smart-extrusion.com)



**Drying has never  
been this efficient:  
ETA plus<sup>®</sup>**

 think materials management



**LUXOR A**

ETA plus<sup>®</sup> considerably reduces  
energy consumption and protects  
materials.

motan-colortronic gmbh - info@motan-colortronic.de  
[www.motan-colortronic.com](http://www.motan-colortronic.com)



### Chemical Recycling Europe Annual Conference (CRE)

13. - 14. 10. 2022

Brussels, Belgium

[www.chemicalrecyclingeurope.eu](http://www.chemicalrecyclingeurope.eu)

### 4TH EAST AFRICA INTERNATIONAL PPPEXPO AFRICA ETHIOPIA 2022

(Plastic, Printing and Packaging Exhibition)

18. - 20. 10. 2022

Addis Ababa, Ethiopia

[www.expogr.com/ethiopia/pppexpo/](http://www.expogr.com/ethiopia/pppexpo/)

### K 2022

19. - 26. 10. 2022

Düsseldorf, Germany

[www.k-online.com](http://www.k-online.com)

### wire South America TUBOTECH

25. - 27. 10. 2022

[www.wire-south-america.com](http://www.wire-south-america.com)

[www.tubotech-online.com](http://www.tubotech-online.com)

### INDIA ESSEN WELDING & CUTTING 2021

23. - 25. 11. 2022

Bombay, India

[www.india-essen-welding-cutting.com](http://www.india-essen-welding-cutting.com)

### Plast Eurasia

23. - 26. 11. 2022

Istanbul, Turkey

[www.plasteurasia.com](http://www.plasteurasia.com)

### ICE Europe 2023

14. - 16. 03. 2023

Munich / Germany

[www.ice-x.com](http://www.ice-x.com)

### Chinaplas 2023

17. - 20. 04. 2023

Shenzhen / PR China

[www.chinaplasonline.com](http://www.chinaplasonline.com)

### interpack 2023

04. - 10. 05. 2023

Düsseldorf, Germany

[www.interpack.de](http://www.interpack.de)

### PLAST 2023

05. - 08. 09. 2023

Milan, Italy

[www.plastonline.org](http://www.plastonline.org)

## German Plastics and Rubber Machinery Industry Currently Facing Major Challenges After a Good Previous Year

■ "German plastics and rubber machinery manufacturers can look back on the year 2021 with satisfaction, achieving a turnover plus of 12 per cent," said Ulrich Reifenhäuser, Chairman of the Plastics and Rubber Machinery Association in the VDMA, summarising the situation. "It didn't turn out to be a record year, as the impetus from the automotive sector in 2018 and 2019 was too strong for that, but we are more than satisfied with the order intake in 2021 as a whole (up 39 percent against the previous year)," Reifenhäuser continues.

Currently, the order books of companies are still reasonably well filled, but due to supply chain problems resulting from lockdowns and the Ukraine war, it is becoming increasingly difficult for companies to convert orders into turnover. Added to this are the rapidly rising prices for raw materials and energy. And finally, after the small interim peak in 2021, there is now a saturation effect in addition to a base effect. Both these factors mean that the new order volume is declining.

"In the first four months of the current year, new orders fell 17 per cent short of those of the same period last year," says Thorsten Kühmann, managing director of the trade association, explaining the reason for the many worries among plastics and rubber machinery manufacturers. "Availability of supplier parts is the predominant issue in the mechanical engineering sector, which, according to surveys, will become more acute again in the coming months before the sector can expect it to ease," Kühmann continues. The uncertainty in the world market as a result of the Ukraine war is doing the rest. For this reason, the trade association recently revised its turnover 2022 forecast of 5 to 10 per cent, and now expects a sideways move-

ment, or at best a small increase of no more than 2 percent.

Alongside climate protection and digitalisation, the circular economy is one of the key themes of K 2022. If the plastics cycle is to be successful, recyclable products are needed, as well as high-performance machines and systems that can turn plastic waste into good quality recyclates, and then process the recyclates into new, high-quality products.

At the VDMA Circular Economy Forum on the open-air site of K 2022, visitors to the fair can see how the circular economy works in practice in the plastics industry. Throughout ten pavilions, the VDMA and its members – manufacturers of plastics machinery and equipment – together with their partners, will be showing the technologies they utilise to make the plastics cycle possible in the first place. This involves the processing of plastic waste, as well as the production of re-granulate, which is then processed into new products. The digitalisation of the procedures plays an important role here.

The VDMA Dome is at the centre of the forum. It is once again the meeting place for everyone who wants to know more about the circular economy in the world of plastics. The installation named "The Machine" provides an overview of the individual process steps of the cycle. Here, 40 companies will present their highlights on the circular economy in video clips, and where these can be found at the fair. The accompanying exhibition shows what is produced on the machines: exciting plastic products made from recyclate.

➔ **VDMA Kunststoff- und Gummimaschinen**  
[vdma.org/kunststoffmaschinen-gummimaschinen](http://vdma.org/kunststoffmaschinen-gummimaschinen)



## NPE2024: The Plastics Show – Planning Team

■ The Plastics Industry Association (PLASTICS) has added association events experts, Smithbucklin, and Smithbucklin-owned company, 360 Live Media, to the team planning NPE2024: The Plastics Show through 2027.

NPE2024, the largest plastics trade show in the Americas, will bring together companies from throughout the plastics value chain, showcasing the newest, state-of-the-art plastics technology and industry innovations. Smithbucklin will provide exhibitor sales and support services and 360 Live Media will deliver marketing and media strategies to the NPE and PLASTICS team.

"We want the best in the business working on NPE," said Glenn Anderson, COO at PLASTICS. "We talked to a lot of groups, and it was clear that

Smithbucklin and 360 Live Media bring the right combination of successful association experience and events expertise to the table."

NPE® is a flagship brand and event for PLASTICS, with a pedigree stretching back to 1946.

"Smithbucklin is thrilled to welcome NPE: The Plastics Show to our portfolio of exhibit sales clients," said Tom Myers, Senior Vice President, Sales Services, Smithbucklin. "360 Live Media thrives on working with the most ambitious teams in our space," said Jack Macleod, President of 360 Live Media. "We look forward to leveraging the full heft of our combined sales and marketing teams to drive results for NPE and PLASTICS."

In 2018, NPE staged its largest-ever show with 2,182 exhibiting compa-

nies occupying more than 1.2 million net square feet of sold-out exhibit floor space. PLASTICS COO Anderson, a then-PLASTICS member and former Chair of NPE2018, concluded, "I'd like nothing more than to see NPE2024 blow our 2018 numbers out of the water, and Smithbucklin and 360 Live Media are the right partners to help us do it."

➔ **The Plastics Industry Association (PLASTICS)**  
[www.plasticsindustry.org](http://www.plasticsindustry.org)

**Smithbucklin**  
[www.smithbucklin.com](http://www.smithbucklin.com)

**360 Live Media**  
[www.360livemedia.com](http://www.360livemedia.com)

## New Carbon Reduced Masterbatch

■ Gabriel-Chemie has been producing its well-known quality masterbatch under the brand name "Maxithen" since 1970. As a supplement to the "Maxithen" products, the company recently presented its new sustainable product lines "MaxiLoop" and "MaxiBlue".

At the same time, Gabriel-Chemie presents new white premium masterbatch with a 10% reduced CO<sub>2</sub> foot-

print. The formulations have been optimised, raw materials with a reduced carbon footprint are used and now offer customers a product to reduce their carbon footprint.

For the resource-saving production of the CO<sub>2</sub>-reduced white, 100% energy from renewable sources is used at the Austrian site, which consists, among other things, of self-generated electricity from our own photovol-

taic system. This represents a serious alternative without having to compromise on performance, functionality or application. An EU and FDA approval enables the CO<sub>2</sub>-reduced white to be delivered worldwide and to provide further sustainable solutions for customers.

➔ **Gabriel-Chemie Gesellschaft m.b.H.**  
[www.gabriel-chemie.com](http://www.gabriel-chemie.com)



## Portfolio of Circular Base Chemicals Introduced

■ Borealis is strengthening its EverMinds™ circular product offering with Borvida™, a range of sustainable base chemicals.

The Borvida portfolio will offer base chemicals or cracker products (such as ethylene, propylene, butene and phenol) with ISCC Plus-certified sustainable content from Borealis sites in Finland, Sweden and Belgium. The move is part of Borealis' broader commitment to a Future-Positive Revolution, in which the unrivalled benefits of base chemicals and polymers can be enjoyed at minimal impact to the planet.

"We are committed to helping to solve the climate crisis through offering credible and sustainable solutions," explains Thomas Van De Velde, Borealis Senior Vice President Hydrocarbons & Energy.

"With the Borvida portfolio, we're enabling our customers to respond to the growing market demand for sustainably-produced base chemicals without compromising on quality or efficiency. With launching our Borvida portfolio, we are continuously striving towards reinventing essentials for sustainable living."

The portfolio will initially comprise Borvida B, from non-food waste biomass, and Borvida C, from chemically-recycled waste. In the future, the range will evolve to include Borvida A, sourced from atmospheric carbon capture. Borvida is complementary and is the building block to Borneowables™, a portfolio of polyolefins based on renewably-sourced second generation feedstocks, and Borcycle™, which offers circular polyolefins produced from mechanically- and chemically-recycled plastic waste.

Borealis produces a wide range of base chemicals for use in numerous industries based on various feedstock, such as naphtha, butane, propane and ethane. Through its olefin units (steam cracker and propane dehydrogenation), it converts these into the building blocks of the chemical industry: ethylene, propylene and C4 hydrocarbons (butylenes, ethyl tertiary-butyl ether (ETBE) and butadiene), and C5-6 hydrocarbons (pygas, phenol) among others.



*Borvida™ will be produced in various Borealis ISCC Plus certified production locations, including Porvoo, Finland (Photo: © Borealis)*

The basis of the Borvida portfolio is Mass Balance, a Chain of Custody model that enables sustainable content to be tracked, traced, and verified through the entire value chain, offering sustainability-assured products from feedstock to end product. Using this model, circular alternatives can be offered in a cost-effective and environmentally-conscious way, which can be scaled up quickly without compromising on quality or efficiency.

Borvida can be used for a wide range of different polymer and chemical applications, also beyond polyolefins (PO). Non-PO polymers, such as polycarbonates, acrylonitrile butadiene styrene (ABS), super absorbant polymer (SAP) and other chemicals, are utilised for various end applications.

■ Borealis AG  
[www.borealisgroup.com](http://www.borealisgroup.com)

## Two New License and Engineering Agreements for Confidential Client Signed

■ ECI Group has signed two license agreements for Process Technology and Engineering Design with a confidential client in China. The two lines will be capable of producing 50,000 tonnes per year of Ethylene Butyl Acrylate (EBA) and 100,000 tonnes per year of Ethylene Vinyl Acetate (EVA) respectively, with the ability to produce other as-

sociated high-pressure copolymers in the future.

The plants will be part of the client's refining and petrochemical integrated project, a mega complex to be located in the Province of Jiangsu. ECI Group will provide the technology, design, and training for the two lines, as well as support through commissioning, start-up, and production.

Repsol, the multi-energy company, is the technology partner of ECI Group and will provide its extensive technical expertise on these kinds of plants and products. Repsol has several LDPE, EVA, and EBA plants in its industrial complexes in Spain and Portugal and has over 40 years of experience producing polymers in high-pressure facilities.



The plants will use high-pressure autoclave technology that has its roots in the heritage ICI process to manufacture of Polyethylene. ICI first created LDPE in the 1930s, and ICI partnered with ECI Group's subsidiary company Simon Carves over five decades to deliver over 67 operating reactor lines around the world. The ECI Group design offers significant improvements in the product range, reliability, and expandability to the original ICI technology, and is optimized to make use of modern materials, design techniques, standards, and industry best practices for construction, operation, and maintenance.

"These agreements include the first EBA license and ECI's fourth high-pressure copolymer license in 12 months," said Joaquin Flores, President and CEO of ECI Group. "These achievements serve to establish ECI's position as the technology of choice for producers of high-pressure polyethylene. ECI Group is already recognized globally as the world's leading



provider of engineering and technical services for high-pressure polyethylene facilities, having worked with every major current producer and licensor. Once again, we have been able to demonstrate the benefits Repsol's in-depth product knowledge and market reputation to further enhance ECI Group's established exper-

tise. We look forward to a long and successful partnership with this well-established client who have made a great impression on us during our discussions with their level of integrity, vision and professionalism."

➔ ECI Group  
www.ecigrouponline.com



For over **50 years** a landmark in the international market for the **manufacturing** of **complete mixing plants**

**PVC DRY BLEND - POWDER COATINGS  
MASTERBATCH AND PIGMENTS - THERMOPLASTIC RUBBER  
WOOD PLASTIC COMPOSITES**

PLAS MEC S.R.L.  
Via Europa, 79 - 21015 Lonate Pozzolo (VA) ITALY  
Tel: +39 0331 301648 - E-mail: comm@plasmec.it  
www.plasmec.it



Hall 9, Stand 9A40



## Distribution Agreement for Brazil Signed

■ The Cologne-based company BIO-FED and the Brazilian distributor Piramidal signed a distribution agreement for the Brazilian market in April 2022.

BIO-FED is a branch of AKRO-PLASTIC GmbH, member of the Feddersen Group and an expert in developing and producing biodegradable and/or biobased compounds under the brand name M·VERA®. This grade range consists of biodegradable compounds, most of them are also partially to fully biobased. Matching sustainable color, black and additive masterbatches with the brand name AF-Eco® can also be provided.

The portfolio was expanded with ISCC PLUS and REDcert<sup>2</sup> sustainable-certified compounds made from biomass-balanced PP. For these product lines M·VERA® PPH and M·VERA® PPC, there are specific AF-CirColor®, AF-CirCarbon® and AF-CirComplex® masterbatches based on biomass-balanced carrier material.

"We see Brazil as an emerging market for sustainable plastic products and want to gain a presence in this market with the help of our new distribution partner", says Dr. Stanislaw Haftka, Sales Director at BIO-FED. "With Piramidal, we have a competent and experienced partner at our side in this region who has a strong network in various industries in Brazil", Haftka continues.

Piramidal is one of the Brazilian leaders in the thermoplastics distribution market. Offering a complete portfolio of resins with focus on excellence and innovation, Piramidal is a solution provider for the Brazilian plastic value chain. The Circular Solutions business unit launched in 2021, has a wide range of sustainable products and services that combine the preservation of the environment and economic growth.

"The partnership with BIO-FED is an important step in our strategy to bring complete sustainable solutions to the mar-



*Bioplastics on their way to the Brazilian market*

ket. Bioplastics have huge growth potential in the coming years, and together we will be able to support our customers on this path." says Fábio Koutchin, Circular Solutions Manager at Piramidal.

Piramidal will distribute the complete M·VERA® product range for blown film extrusion, injection moulding, extrusion and thermoforming applications in Brazil, as well as the matching masterbatches.

### ► BIO-FED

Branch of AKRO-PLASTIC GmbH  
Dr. Stanislaw Haftka,  
stanislaw.haftka@bio-fed.com

### Piramidal

Fábio Koutchin,  
fabio.koutchin@piramidal.com.br

## Successfully Certified

■ In November 2021, four members of the Feddersen Group, AKRO-PLASTIC and its branches AF-COLOR and BIO-FED, as well as PolyComp, announced certification with ISCC PLUS. With K.D. Feddersen Holding, further companies of the group are now certified with ISCC PLUS.

The certification of K.D. Feddersen Holding GmbH also includes K.D. Feddersen GmbH & Co. KG, K.D. Feddersen GmbH & Co. KG, Succursale France, K.D. Feddersen CEE GmbH, K.D. Feddersen UK Ltd. and K.D. Feddersen Norden AB. In addition, K.D. Feddersen Ueberseegesellschaft mbH has also been co-certified with numerous other non-European companies in the group.

ISCC PLUS is a sustainability certification system for bio-based and recycled materials in the chemical industry (e.g., based on sugar cane, vegetable oil and fat waste or recycle). The certification ensures the traceability of the sustainable material flow along the entire supply chain. Since the value creation process of products in the chemical industry is often very complex, the mass balance approach is used for this purpose.

### ► K.D. Feddersen Holding GmbH

Britt Matthießen,  
britt.matthiessen@kdfeddersen.com



# Packaging Made from Post-Consumer Recycled and Biomass Balanced Materials

■ Mondi has collaborated with Essity and Dow to create new, recyclable secondary packaging for Essity’s feminine care products, using renewable materials and post-consumer recycled content that reduces use of fossil-based materials.

Essity’s feminine care towels were previously packed in bags that already used 50% renewable materials. Extensive research and testing by Mondi however, resulted in the recommendation of a new solution that aligns with Essity’s packaging goals: to work towards 100% recyclability and to use up to 85% biomass, renewable or recycled material in all bags where up to 25% are recycled plastics.

The new packaging contributes to these sustainability goals by using a renewable material and by-product from the paper making industry that is produced from circular feedstock based on the ISCC (International Sustainability & Carbon Certification) mass balance approach. The innovative packaging also contains mechanically recycled content from post-consumer material. Mondi worked with long-term supplier Dow and other companies along the value chain to find the most suitable resin formulation for this solution. The end result is an extruded film that is printed on and converted into a bag.



Mondi and Essity launch packaging for feminine care range made from post-consumer recycled and biomass balanced materials (Photos: Mondi)

Providing the same high-level of protection as the previous alternative, the solution prevents moisture and light damaging the feminine care range, has strong sealing properties and delivers outstanding print quality to maintain on-shelf appeal for Essity’s European recognised brands.

Marjo Kuisma, Regional Sales Consumer Flexibles, Mondi, says: “The challenge was to find the best combination of renewable and recycled content that maintains product quality and the production efficiency already enjoyed by Essity. We tested several options until we found the most suitable solution. Working in collaboration with Essity and Dow validates our EcoSolutions approach; we go back to the start and ask the right questions to ensure we create the best possible solution for our customers.”

■ Mondi  
www.mondigroup.com



We look forward to meeting you!  
Hall 10, Booth F 34

## Facilitate the Use of Recycled Plastics

■ Avient Corporation introduced its PCR Color Prediction Service for polyolefins and polyethylene terephthalate (PET) resins, and the company's new polyolefin antioxidants, Cesa™ Nox A4R Additives for Recycling. These sustainability solutions are specifically designed to improve the customer experience of working with post-consumer recycled (PCR) content for materials used in packaging. Both align with the eight ways Avient helps customers be more sustainable.

The PCR Color Prediction Service, helps brand owners understand what colors are achievable based on the amount of PCR used. It uses sophisticated technology to determine – through prior color matching – if colors are feasible in a new application that incorporates PCR content. A first of its kind for the plastics industry, this internally developed solution also calculates how much PCR content can be added to an existing application without affecting its signature color.

Using proprietary software, Avient experts measure resin characteristics to identify the gamut of colors that can be successfully reproduced in a specific PCR-based material.



*Avient's new sustainable solutions are its PCR Color Prediction Service for polyolefins and polyethylene terephthalate (PET) resins, and its new polyolefin antioxidants, Cesa™ Nox A4R Additives for Recycling*

This premium service simplifies and accelerates the selection of preferred colors for polymers with PCR content, avoiding time-consuming trial and error. By speeding the evaluation process, the service also gives greater flexibility to customers that may need to switch from one PCR content source to another, which is especially important due to today's supply variability.

Avient's new Cesa Nox A4R Additives for Recycling are based on a special formulation that protects post-consumer polyolefins against oxidation, which can lead to defects like black spots, gels and discoloration. The antioxidant can be added to PCR content early in the recycling process or incorporated in virgin resin to prepare it for future recycling.

► Avient Corporation  
www.avient.com

## New Construction of State-Of-The-Art Test Lab for Plastics Recycling Applications

■ Coperion has initiated the construction of a state-of-the-art recycling test lab at its Niederbiegen/Weingarten, Germany, production facility. The new Coperion Recycling Innovation Center will be built in the immediate vicinity of Coperion's existing Test Center for Bulk Solids Handling. Driven by rising demands worldwide for a circular plastics economy, a clear trend has taken shape over the last years toward more recycling. Coperion is meeting this trend, not only with its equipment and processes designed for recycling applications, but also with its new Recycling Innovation Center. At the facility, customers will be able to develop and test new, sustainable products and



*At the new Coperion Recycling Innovation Center in Niederbiegen/Weingarten, Germany customers will work together with Coperion experts to develop and test sustainable products and recycling processes (Image: Coperion GmbH)*



recycling processes together with Coperion’s experts. All essential recycling process stages will be covered within the facility including materials conveying, feeding, extrusion, pelletizing, and materials postprocessing. In addition, Coperion will conduct its own research activities on plastics recycling in this new Recycling Innovation Center.

With this new addition, the company will expand its test lab capacities, throughout Germany alone, up to 5,000 m<sup>2</sup> (53,819 ft<sup>2</sup>), making it evident that Coperion’s investment for innovation and underscoring its research and development activities, particularly with regard to issues of sustainability is paramount.

Markus Parzer, President of the Polymer Division and Managing Director of Coperion GmbH, said: “Worldwide demand for state-of-the-art, efficient plastics recycling solutions will continue to grow in the years to come because of the constantly increasing demands of environmental legislation, such as that within the framework of the European Green New Deal, and due to changing consumer behavior and environmental consciousness. In deciding to create this new Recycling Innovation Center, we have set clear priorities to be an active partner with our customers by offering our advanced technologies and established expertise, as we work with them along the path toward greater

sustainability and a functioning circular economy.”

Added Bernd Neumann, Coperion Weingarten and Niederbiegen Site Manager: “We are confident that, with our new Recycling Innovation Center, equipped with the most modern technology for high-quality and innovative recycling processes, it will be an attractive added value for our customers in the plastics industry. At the same time, the new facility will allow the addition of interesting, long-term career opportunities for those in the region.”

➡ Coperion GmbH  
www.coperion.com

# Precision Wall Thickness Measurement

## RAYEX S

- Easy and quick set up for new products
- Fast eccentricity and diameter measurement
- Added longevity due to high-quality xray source





SWISS PRIME MEASURING SINCE 1957

19. - 26. 10. 2022  
Düsseldorf,  
Germany  
Stand: 10E27





Family owned since 1957, Zumbach is a global leader in the industry.  
Driven by innovation and experience.  
We are here for you and ready to build the future together.

www.zumbach.com • sales@zumbach.ch

## Portfolio with Catalysts and Absorbents for Plastics Recycling Introduced

■ BASF launches PuriCycle®, a new line of advanced high-performance products for the purification of most complex waste plastics pyrolysis feeds. The PuriCycle portfolio includes novel catalysts and adsorbents developed to selectively remove or convert a wide range of impurities in pyrolysis oils and enable downstream processing of circular plastics streams. PuriCycle can help customers meet industry compositional compliance standards, benefit from high efficiency purification and upgrading solutions, and increase their flexibility in the chemical recycling process of plastics.

PuriCycle purifies pyrolysis oils, a secondary raw material obtained from the chemical recycling of plastic waste that is fed into the production process for new plastics at the beginning of the value chain. Purification of pyrolysis oils obtained from waste plastics is among the most demanding technical tasks in chemical plastics recycling. Impurities, such as halogen, nitrogen, oxygen and sulfur compounds but also higher levels of reactive components such as dienes, complicate the downstream use and impose strict limitations on the further processing of such streams in the production of new materials.

## Reclassification of Recyclability of Coextruded Polyethylene/Polyamide Film Structures

■ The „Stiftung Zentrale Stelle Verpackungsregister“ (Central Agency Packaging Register) has reclassified the recyclability of polyamides in the minimum standard for assessing the recyclability of packaging subject to system participation pursuant to Section 21 (3) VerpackG: Since September 1, coextruded polyethylene (PE)/polyamide (PA) film structures have been recognized as mechanically recyclable.

“We appreciate the decision of the Stiftung Zentrale Stelle Verpackungsregister,” said Dr. Rolf-Egbert Grützner, Senior Manager Technical Support for Ultramid® extrusion polyamides at BASF.

“It was time to correct the categorization of polyamide 6 and also the related PA6/6.6 co-polyamides and put them on a solid updated basis.”

As early as June 2021, the independent testing and certification facility cyclos-HTP systematically examined and confirmed the recyclability of PE/PA multilayer films on behalf of BASF.

The use of coextruded PE/PA film structures in multilayer films makes it possible to produce very thin films, which significantly reduces the use of plastics and also the amount of waste. BASF will present more about the value-adding use of polyamides at the K 2022.

■ BASF SE  
[www.catalysts.basf.com/puricycle](http://www.catalysts.basf.com/puricycle)  
[www.basf.com](http://www.basf.com)

## New Publication Grants Insight Into the Mechanical Recycling of PE/PA Multilayer Films

■ In a new publication, BASF and Institute cyclos-HTP reveals details of the mechanical recycling of coextruded flexible packaging films containing polyamides (PE/PA multilayer films). The independent testing and certification body cyclos-HTP systematically investigated the recyclability of PE/PA multilayer films on behalf of BASF and confirmed it in June 2021. The results and conclusions of these investigations are now available in a 25-page publication on the websites of BASF and cyclos-HTP.

In the tests, coextruded PE/PA multilayer films with PA6 and PA6/6.6 concentrations of up to 30 percent were used with tie layer materials. Based on the established CHI standard, cyclos-HTP tested the recycling compatibility and recyclability of these films in the PE film stream from commercial sorting processes for household flexible plastic packaging waste.

cyclos-HTP is already using these updated results for the differentiated certification of the recyclability of individual flexible PE/PA packaging structures by performing case-by-case reviews of packaging structures that were previously classified as incompatible for recycling (according to section 4.3 of the minimum standard for determining the recyclability of packaging subject to system participation pursuant to section 21 (3) VerpackG, Central Agency Packaging Register, 2021).

The publication is accessible via the following links:

[https://chemicals.basf.com/global/en/Monomers/polyamide\\_intermediates/mechanical-recycling.html](https://chemicals.basf.com/global/en/Monomers/polyamide_intermediates/mechanical-recycling.html)  
 and  
<https://www.cyclos-htp.de/publications/>



## Market Study: Plastic Pipes

■ The construction industry is increasingly suffering from higher prices for building materials. The war over Ukraine and the ongoing corona lockdowns in China are also directly or indirectly affecting plastic pipe manufacturers. So far, the construction industry has come through the crisis better than other industries. Nonetheless, Ceresana’s fifth analysis of the global market for plastic pipes doesn’t expect a market recovery until 2023 at the earliest.

Despite disrupted supply chains, more expensive raw materials and other current challenges, the future outlook remains intact for producers of plastic pipes, pipe components and fittings. Whether heavy rains or droughts are on the increase, extreme weather phenomena in the wake of climate change are forcing investment in more efficient, higher-performance water pipes. Demand for easy-to-maintain plastic pipes for the irriga-

tion of agricultural land will grow in the coming years. Ceresana expects global demand for plastic pipes in the agricultural sector alone to increase by around 2.7% per year up to 2031.

The study in brief: Chapter 1 provides a presentation and analysis of the global market for plastic pipes - including forecasts up to 2031. Revenues, (in USD and EUR) as well as production and demand (in tonnes) of plastic pipes are given for each region of the world.

In Chapter 2 the 16 most important countries are considered individually in terms of demand, imports and exports. The production and demand volumes are divided into the plastic types polyethylene (PE), polypropylene (PP), polyvinyl chloride (PVC) and other plastics. Additionally, the demand for each country is broken down into the individual application areas.

Chapter 3 provides useful company profiles of the most important

## Market Study: Plastic Pipes

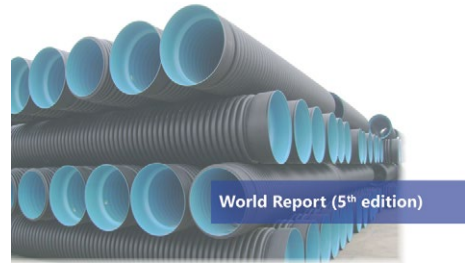

Ceresana  
Market Research Since 2002

plastic pipe manufacturers, structured according to contact details, revenues, profit, product range, production facilities and brief profile. Detailed profiles are provided by 92 manufacturers.

➔ Ceresana  
[www.ceresana.com/en/market-studies/industry/plastic-pipes-world](http://www.ceresana.com/en/market-studies/industry/plastic-pipes-world)

## New Chief Financial Officer

■ Davis-Standard announced that Raje Dwaraka has been appointed Chief Financial Officer (CFO). In her new role, Dwaraka will lead Davis-Standard’s finance team and partner with business unit leaders. She will also be instrumental in designing and executing the company strategy.



Raje Dwaraka

„Raje is a talented financial leader, and we are thrilled to have her as part of our executive leadership team,” said Giovanni Spitale, Davis-Standard’s Chief Executive Officer. “She brings a proven track record of leading global teams, delivering sound financial strategy, and close partnership with business leadership – all of which will be key to continuing the growth trajectory that we are on”.

Raje obtained her CPA license from the Illinois Board of Public Accountants and also holds a Chartered Accounting (CA) degree from India.

➔ Davis-Standard, LLC  
[www.davis-standard.com](http://www.davis-standard.com)

**From the Simple to the Sublime**

**Series 800 crosshead for two to six layers**

The latest generation of the **Series 800 crosshead** is designed to run two to six layer extrusions for high quality, high accuracy 1/8" to 6" OD tubing for medical, automotive, appliance and industrial applications.

Ideal for fluoropolymer multi-lumen, multi-layer tubing for fuel lines or thin layer combinations of polymers and adhesives to 0.02mm or less.

Features patented **Guill Feather Touch**® concentricity adjustment to eliminate leaking.

Please visit [www.guill.com](http://www.guill.com)

Guill

EXTRUSION TOOLING

10 Pike Street  
West Warwick, RI 02893  
USA  
sales@guill.com Attention: Bill Conley

## Certification Scheme for Plastics Recyclers Published

■ RecyClass extends its scope with the first European-wide audit scheme for plastic recyclers based on EN 15343 and fulfilling the requirements for conformity assessment described in ISO 17065. This certification will support the industry in complying with upcoming market and legal requirements in a harmonised, transparent and reliable manner.

“The new RecyClass Recycling Process Certification[1] is the first step of ensuring the origin of recycled plastics,” said, Paolo Glerean, RecyClass Chairman. “Apart from complementing the existing Recycled Plastics Traceability Certification[2] which will recognise RecyClass Recycling Process as Supplier’s Certificate, it will also create synergies and ensure verification of the entire chain of custody requirements for recycled content in products. With this we aim to provide a set of robust tools that will support the industry in substantiating their claims on recycled content and on the use of plastics recyclates,” he added.

As a non-profit initiative, RecyClass aims at harmonising the methodology for the calculation and reporting of recycled plastics. The Recycling Process Conformity Assessment Scheme was developed following the traceability

principles[3] in line with a controlled blending chain of custody model as defined in ISO 22095. The Scheme covers requirements on plastics traceability, quality management, calculation of recycled content and environmental performance. Additional requirements are set for food contact processes, cosmetics and household applications, as well as corporate social responsibility. Furthermore, the food contact modules have been developed according to the new requirements in the revised Regulation on recycled plastics in food contact.

The compliance of the new RecyClass Recycling Process Certification is being evaluated by the European Co-operation for Accreditation via the Spanish Accreditation Body – ENAC[4] as a first step towards the issuing of certificates compliant with ISO 17065 via accredited certification bodies.

[1] RecyClass Recycling Process Certification

[2] RecyClass Recycled Plastics Traceability Certification

[3] EN 15343

[4] Entidad Nacional de Acreditación. Inicio - Portal ENAC

► RecyClass  
www.recyclclass.eu

## New Flame Retardant Masterbatch Made of Post-Consumer Recycled Polypropylene

■ Gabriel-Chemie Group, in collaboration with Vivi Srl, has developed a new flame retardant masterbatch for the moulding of second-life polypropylene products. This innovative masterbatch enables to obtain the Italian class 1 according to UNI 9174.

Gabriel-Chemie, confirms its market leadership in the research, development and innovation of flame retardant masterbatch for the furniture sector, a sector where it now boasts numerous international approvals for various polymers, also confirms the attention to eco-sustainability projects. Sustainable products, which are already making a major contribution to preserving the planet, are in greater demand than ever. GCs innovations and research projects are aimed precisely at this – producing plastic as a valuable and reusable material.



@Vivi Srl / Gabriel-Chemie

Vivi has identified the ideal polypropylene, made entirely with post-consumer waste. By selecting the most suitable material to create design furniture components, with a high degree of aesthetics required

and large thicknesses. Sustainability, design and functionality no longer contradicts each other.

► Gabriel-Chemie Gesellschaft m.b.H  
www.gabriel-chemie.com



## Used Machinery Trading with a Positive Contribution to the CO<sub>2</sub> Balance



*The two GINDUMAC founders & managing directors Benedikt Ruf (left) and Janek Andre (right)*

■ From the dealer's point of view, maximizing profit margins and customer satisfaction are the top priorities in the buying and selling process for used machinery. Sellers and buyers expect professional management and best prices.

Used equipment dealers have an interface function in the connection between the seller, the used machine, and the buyer. Transaction management creates added value for all parties involved. The seller receives new liquidity, the buyer new production capacity and the dealer generates a positive trading margin. What creates a win-win situation for the companies involved also applies to the CO<sub>2</sub> balance. This is a new perspective on the used machinery trade that mostly goes unnoticed.

Since the manufacturing process of a new machine generates significant CO<sub>2</sub> emissions, the decision to buy a used machine ensures that new CO<sub>2</sub> emissions are avoided. This results in a positive contribution to the carbon footprint when the life cycle of a used machine is extended through resale.

Used machinery dealer GINDUMAC has been analyzing the life cycles of the machines it sells since it was founded in 2016. "The life cycles in metal, sheet metal and plastics processing are very different. It depends a lot on the machine park concept, application depth and manufacturer," says Benedikt Ruf, Managing Director of GINDUMAC GmbH.

"Nevertheless, our empirical values show a tendency for used metal work-

ing and sheet metal forming machines to change hands around three to four times on average. In plastic injection molding, we see that machines are generally used by around two to three different companies before they are scrapped," says Ruf.

The extended life cycle and the cross-border sale of used machines demonstrate the positive impact chain for the carbon footprint. This usually starts with manufacturing companies, which always must be at the highest technological level and consequently regularly renew their machinery.

At GINDUMAC, in addition to high customer satisfaction and professional transaction management, the topic of "Circular Economy" is also an important guiding principle of the company's mission. "What counts in used machinery trading are qualitative machines, the best possible prices for sellers and buyers, and smooth processing. This is also the core of our business model and the primary interest of our customers. Nevertheless, we also see an overarching perspective that equally drives us to make a positive contribution to the circular economy and indirectly to climate protection every month," comments Janek Andre, CEO of GINDUMAC GmbH.

➔ **GINDUMAC GmbH**  
[www.gindumac.com](http://www.gindumac.com)

## Flexible electrical heating technology

- Co-Extrusion hoses
- 2K-heated hoses
- Heating plates
- Heating tables
- Heating sleeves
- Spezial solutions



### Hillesheim GmbH

Am Haltepunkt 12  
D-68753 Waghäusel • Germany  
Phone: 49 72 54 / 92 56-0  
E-Mail: [info@hillesheim-gmbh.de](mailto:info@hillesheim-gmbh.de)  
[www.hillesheim-gmbh.com](http://www.hillesheim-gmbh.com)

## New Technical Manager

■ As of August 16, 2022, Guenther Klammer is responsible for the research and technical developments of Next Generation Recyclingmaschinen GmbH as the new technical manager (CTO). With this reinforcement in the management, the team of plastics recycling machine specialists will ensure the technical progress of products and services also in the future and further expand their position as a technological pioneer.

For the new position at NGR, Klammer brings his profound technical expertise as well as many years of industry experience in plastics recycling. "Implementing innovative and sustainable solutions in plastics recycling is my passion, and I am looking forward to the new tasks at NGR," says Klammer, who intends to continue driving the Feldkirchen-based mechanical engineering company's growth course at the highest technical level.

"In recent years, NGR has made a steady progress from a start-up to an internationally successful machine builder, not least due to technically innovative products," explains Josef Hochreiter, CEO of the NEXT GENERATION GROUP. "But we certainly don't want to rest on this success. Because the requirements in plastics recycling are becoming more and more complex worldwide. In order to meet



*Guenther Klammer, new CTO at Next Generation Recyclingmaschinen GmbH (Photo: NGR)*

precisely these increased requirements and to continue to offer one step ahead solutions, we have once again strengthened our forces."

► Next Generation Recyclingmaschinen GmbH (NGR)  
[www.ngr-world.com](http://www.ngr-world.com)

## Reciprocating Head Introduced

### *Automated Extrusion Process Drastically Changes the Extruded Profile*

■ Guill Tool, a global manufacturer of extrusion tooling, has released its new reciprocating head. The traditional tip and die assembly is replaced with a linear reciprocating assembly that changes the tube's profile within a given length. This process is repeated throughout a single extrusion run without interruptions. Cutting capability, in association with the extrusion speed, cuts the finished product to length.

While cost and value stream activities are reduced, quality is improved. Only one extrusion run is needed to produce a finished product, as opposed to multiple extrusion runs with tooling changes along with a manual assembly operation to connect different tubing shapes. Guill's new reciprocating head eliminates an assembly operation. It also eliminates in-process inventory. Thus, there is no need for storage of various tubing

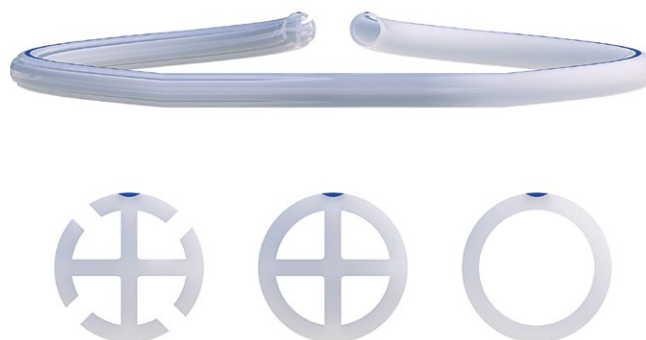
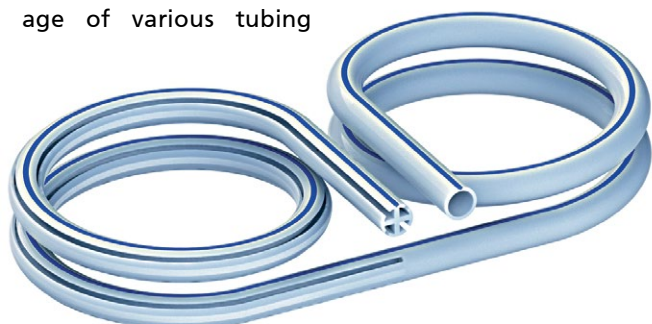

shapes and connectors needed for assembly, fulfillment of orders and replenishment of finished goods.

Furthermore, the reciprocating head eliminates a connecting piece, allows JIT production and products made-to-order. Lastly, it reduces total run time from receiving the order to shipping. For more information:

► Guill Tool & Engineering  
[www.guill.com](http://www.guill.com)



# THE NEW WARP CP

## RADAR MEASUREMENT SYSTEM FOR CORRUGATED PIPES

- Patented measuring method
- Non-destructive, contactless and automated inline measurement of all relevant structures of the corrugated pipe
- Repair of critical thick and thin spots
- Operator-independent measurement
- For wall thicknesses from 1.7 mm (0.67 in)
- For pipe sizes from 300-1000 mm (inner diameter)

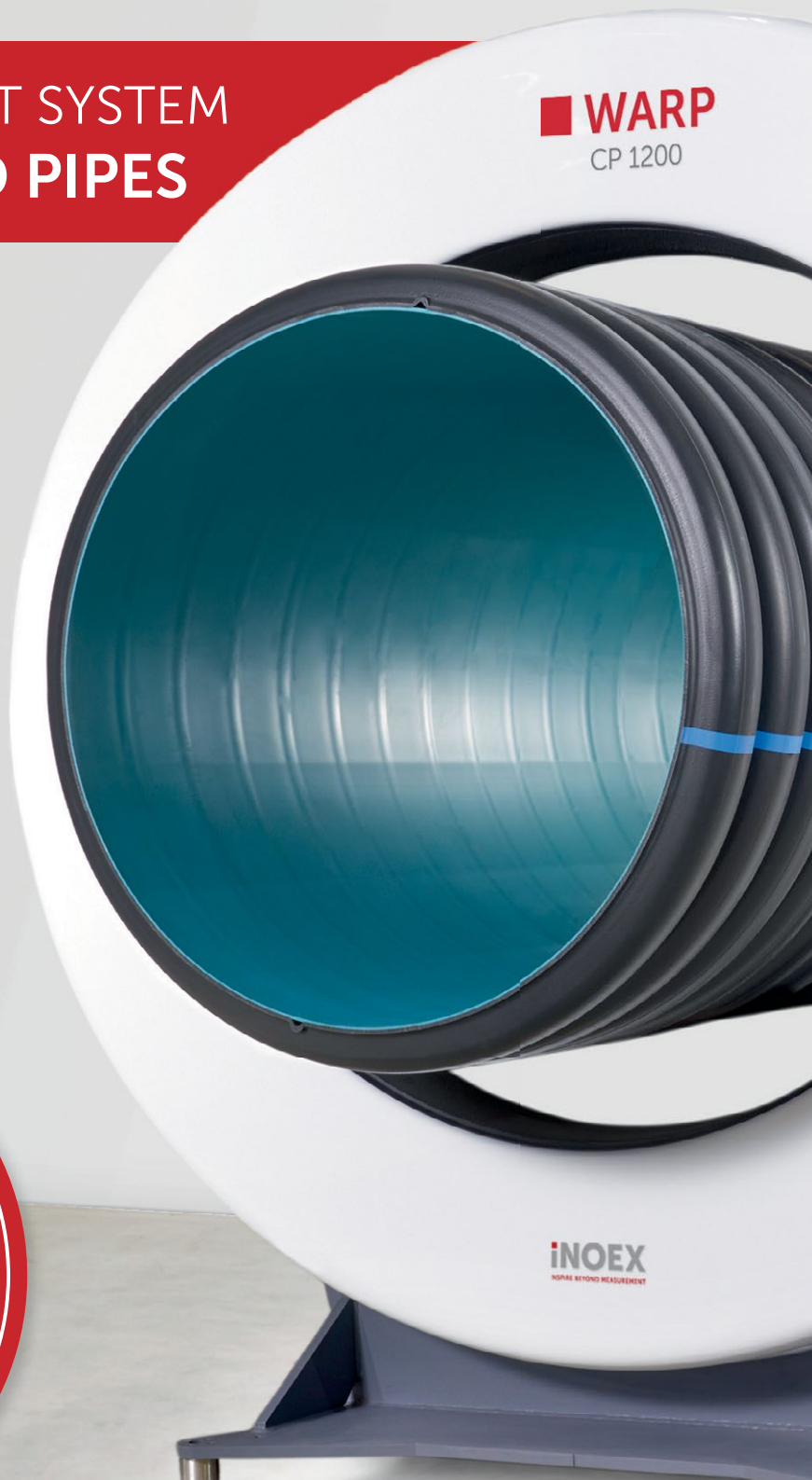

Experience the new  
WARP CP at K 2022  
Hall 10  
Booth C46

## New Choices of Gravimetric Feeders

■ With over 30 years of experience in gravimetric blending and dosing technology, Maguire is pleased to introduce a new feeder line that can be configured in any optimal way to accommodate various processing requirements. The new feeder models allow for up to 4 different size auger feeders, all located on one mounting frame, using a single common touch screen control. In addition, the company is introducing a Volumetric Feeder (MVF) option. These new feeder models provide ultimate flexibility for injection molding, extrusion, blow molding and extrusion control applications.

Since 1980, Maguire feeders have helped processors save tens of thousands of dollars per year thru accurate dispensing of color and additives. The standard MGF line provides robust hardware, integrated with industry leading software, to provide consistent control and accuracy that is intelligent and easy to use. This standard Maguire Gravimetric Feeder (offered in 3 auger sizes: 3/8", 1/2" and 1") have historically included an analog or touchscreen control, along with different mounting frame options and high temp configurations. The series offer twin load cell technology with a dosing accuracy of  $\pm 0.2\%$ .

These new available options allow processors much more flexibility and increased performance for all types of molding & extrusion processes. These options can all be retrofittable in the field with current Maguire feeder equipment.

The new Maguire MGF+ line incorporates the standard gravimetric feeder options and includes up to (4) different size auger feeders on one mounting frame all using a common touch screen control. This allows the flexibility to dispense multiple additives/materials within one frame and one controller. The center hopper dispenses the virgin material. For each unique feeder the dispensed material is measured precisely and accurately to

maintain the correct desired percentage – all controlled by one touch screen controller.

The new Maguire MGF+ 100L incorporates up to (4) different size auger feeders, and includes a virgin hopper that is on a pair of load cells so that the material within this hopper is also being weighed and controlled (by the same controller). All materials are 100% weighed and the additive components are ratioed to the primary component, regardless of changing throughput. This option is ideally used for extrusion applications.

The Maguire MGF+ 100X takes the process control one step further by including an extrusion control package, where the extruder drive control is managed with the same touch screen controller as the hopper and the feeders. This model used exclusively for extrusion applications streamlines the entire process and includes the center loss-in-weight (LIW) hopper along with up to four auger feeders. The LIW controller monitors the actual throughput of the line. The target throughput is set on the controller and when the operator switches to automatic mode, the controller will adjust the extruder drive to maintain target weight per hour and/or weight per length.

Processors can also now choose from Maguire's latest, most economical version of their volumetric feeder, the MVF. The MVF is designed for simple volumetric dosing of color concentrate and/or additive material. It utilizes a simple (digital push button) setpoint control and a stepper motor to provide consistent letdown ratio without any use of load cells. Conversion kits are available for upgrade to full gravimetric capability.

All Maguire Gravimetric and Volumetric Feeders are backed by an industry leading 5-year Warranty.

► Maguire  
www.maguire.com

*The new Maguire Gravimetric Feeding (MGF+) choices are ideal for any type of molding and extrusion process, allowing much more flexibility and increased performance*



**MGF+**

**MGF+ 100X  
MGF+ 100L**

**MGF+ 100B**

**MVF**



## Quadruple Extrusion Line for PVC-U Pipes

■ Sica has recently consigned a high-speed line for multi-extrusion. This new line is specifically designed for feeding, cutting, belling and packaging PVC-U pipes for use as ducts for channelling and protecting electric cables. It can manage pipes produced with the quadruple extrusion method, from OD.16 mm (3/8") to OD. 63 mm (2").

The first machine after the extrusion part is the Combo 63Q, a compact combined (feed and cut) module with four independent units for extruded pipe haul-off and then four shearing units for cuts of superior quality at high extrusion speed, equipped with an effective centralised aspiration system that collects the dust and chips produced.

The next element is the Multibell 75Q belling machine purposely designed to receive quadruple extrusion pipes with independent transit speeds. A new incoming pipe sorting system manages the four simultaneously extruded tubes, forming groups of 2, 3 or 4 pipes depending on their diameter.

The groups formed are carefully heated in a specific forced hot air oven fitted with a twin automatic pipe alignment device. The pipes are heated prior to the belling phase to guarantee sockets of precise, constant and identical lengths for the whole group of pipes processed.

The machine can produce sockets both for gluing ("smooth sockets") and for elastomeric seals. There is an efficient socket cooling system that uses pre-cooled external compressed air, combined with the internal cooling of the belling spindles using recirculated water.

The socketed pipes are then transferred to the A10-63 strapping machine that uses special pick-up arms to remove them from the belling machine bench, forming bundles of strapped pipes of different quantities and configurations (defined by the operator) and with lengths from 2 m (6.6 ft) to 6 m (20 ft).

The pipe bundles are then sent to a tipper conveyor – model A607 – whose job, thanks to a motorised belt, is to position them in line with the final carriage then raise them and load them in the carriage. The system guarantees safe working conditions as the entire line is fitted with perimeter guards with photoelectric barriers and interlocked access.

■ Sica S.p.A.

[www.sica-italy.com](http://www.sica-italy.com)



# LESUN

2022 19-26 Oct  
Düsseldorf Germany

Hall 8b F11-4

## FOCUS

## SCREW | BARREL | SHAFT



Nanjing Lesun Screw Co.,Ltd.

E: [info@lesunscrew.com](mailto:info@lesunscrew.com)

[www.lesunscrew.com](http://www.lesunscrew.com)

## Expanded Line of Compostable Resins for Packaging and Single-Use Applications Launched

■ Green Dot Bioplastics, a leading developer and supplier of bioplastic materials for innovative, sustainable end-uses, has expanded its Terratek® BD line with nine new compostable grades that are targeted for single-use and packaging applications. The expanded offering for film extrusion, thermoforming, and injection molding is in line with Green Dot Bioplastics' goal to achieve faster rates of biodegradability in ambient conditions, while meeting the growing sustainability demands of brand owners and consumers.

These new compostable materials are an integral part of the company's extensive bioplastics portfolio which includes biocomposites, elastomers, and natural fiber-reinforced resins all produced at the company's newly expanded manufacturing facility in Onaga, Kan.

"This launch culminates our extensive development of a new category of compostable materials for single-use applications and packaging markets," said Mark Remmert, Green Dot Bioplastics CEO. "We've successfully developed unique materials that have a faster rate of biodegradation in ambient composting conditions and the functional performance that the market demands."

The five new film grades are compostable starch blends that require no tooling or process modifications when run on traditional blown or cast film equipment. Among them are Terratek® BD3003 which exhibits high puncture resistance and tear strength and is heat sealable like linear low-density polyethylene (LDPE) film. Meanwhile, Terratek® BD3300 is a stiff, high-modulus material with high heat resistance and overall properties similar to HDPE film.

The film grades deliver faster rates of biodegradability for home composting, industrial composting, and soil biodegradability. They are targeted for a range of applications including produce bags, bubble wrap, agricultural films, and other lawn and garden packaging. The film materials are completing third-party certification by TÜV Austria, a leading European certifying agency.

Green Dot's new compostable offering also includes three new thermoforming grades which provide a range of properties including clarity. Other grades provide higher heat performance and greater flexibility for applications such as food service packaging, takeout containers, deli packages, and straws. The thermo-

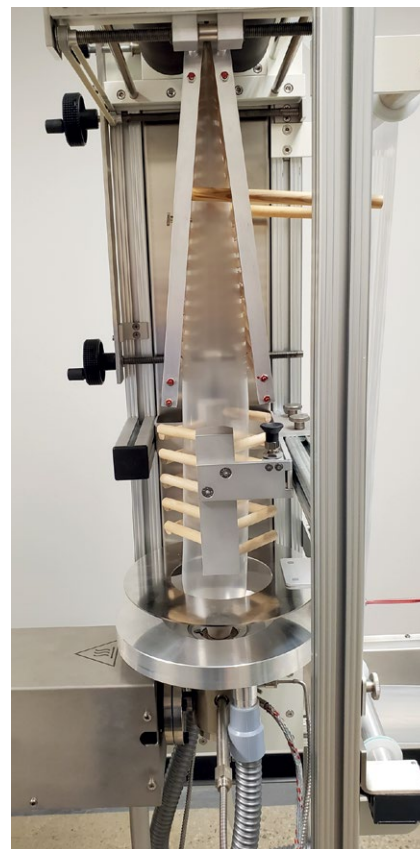

forming grades are also completing final certification by TÜV Austria.

Two injection molding grades round out the new compostable offering.

➔ Green Dot Bioplastics, Inc.  
[www.greendotbioplastics.com](http://www.greendotbioplastics.com)

## PPS Delivers Increased Transmittance and Toughness in Laser Welded Applications

■ Polyplastics, a leading global supplier of engineering thermoplastics, is finding successful use of polyphenylene sulfide (PPS) in laser welded applications such as automotive parts thanks to materials with enhanced capabilities. The company offers DURAFIDE® PPS 1130A1 which delivers greater transmittance and toughness and facilitates laser welding in a range of applications.

Laser welding is a joining method that offers a long list of advantag-

es, but it has been difficult to actually use with PPS due to its low laser transmittance and related mass production issues such as a narrow processing window. Polyplastics' linear-type DURAFIDE® PPS is characterized by its white natural color, as opposed to the reddish-brown natural color of competitive crosslink-type PPS materials. That gives it superior laser transmissibility (light transmissibility in the infrared region) and makes laser welding possible.

DURAFIDE® PPS 1130A1 provides approximately a 6% improvement in laser transmittance which results in a wider processing window for a broad range of welding conditions. The material also delivers an approximately 28% improvement in toughness versus standard grades. This exceptional toughness is important for initial strength and durability. DURAFIDE® PPS 1130A1 also offers strong dimensional stability, low warpage, and chemical resistance.



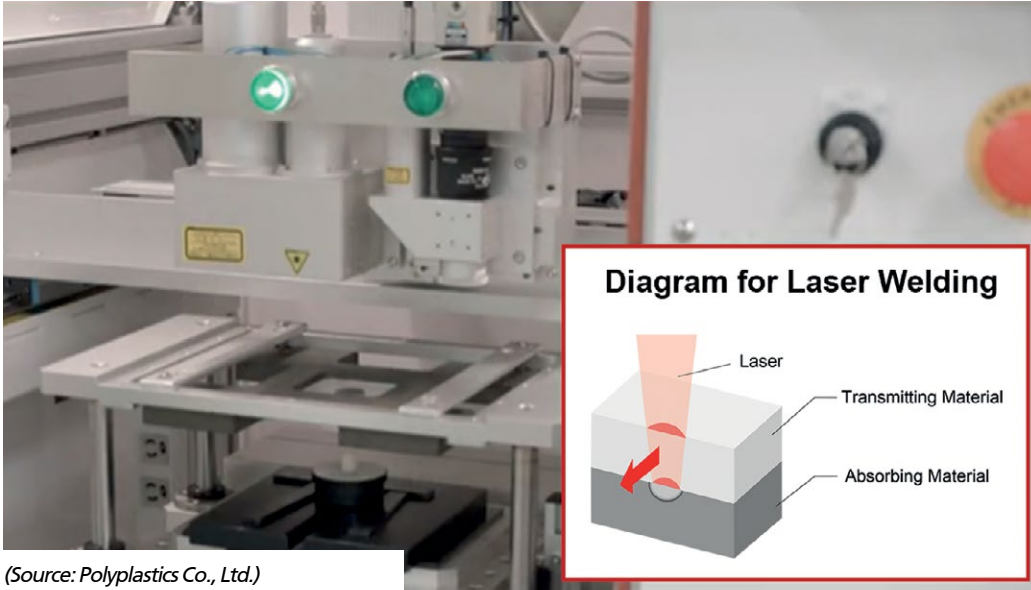

(Source: Polyplastics Co., Ltd.)

DURAFIDE® PPS 1130A1 enables the use of laser welding for production of automotive electric components for which this method could not readily be used before. These parts include electric water pumps, shift actuators, electric-variable valve

timing actuators, solenoid valves, and various sensors.

Polyplastics is currently undertaking a development project to provide even better laser transmittance of PPS and further widen the processing window.

\*DURAFIDE® is a registered trademark of Polyplastics Co., Ltd. in Japan and in other countries.

➔ Polyplastics Co., Ltd.  
www.polyplastics-global.com

SMART RECYCLING SOLUTIONS

NEW DESIGN

ENERGY SAVING

# 100 COMPAC

## TECHNOLOGICAL EVOLUTION

New regeneration lines with a **new design** and higher performance thanks to **greater temperature control** of the various areas and **lower energy consumption**.

**GAMMA MECCANICA**  
RECYCLING LINES FOR PLASTIC MATERIALS

ITALY - Tel. +39 0522.240811 - www.gamma-meccanica.it

Meet us at **K2022** 19-26 October,  
Düsseldorf. **Hall 9, booth C18**

## Circular Economy Packaging

■ TOMRA, the innovation leader for waste and resource management, offers practical solutions to deal with the ever-growing volume of packaging waste. To mark its 50th anniversary, TOMRA has published its next white paper which highlights Extended Producer Responsibility (EPR). This policy principle has the power to accelerate society's shift towards a more circular economy, where resources are reused repeatedly to maximize their value.



EPR ensures that producers and manufacturers take responsibility for the full lifecycle of their packaging – from design to waste collection and recycling, and final disposal. As producers must provide dedicated funding for their own packaging, this policy principle also can incentivize sustainable packaging design and management based on the waste hierarchy to achieve greater environmental outcomes. TOMRA's new white paper, *EPR Unpacked – A Policy Framework for a Circular Economy*, not only defines and examines EPR schemes for packaging waste, but it also serves as a detailed guide for policymakers who design or develop EPR schemes, offering a multi-faceted perspective and practical insights to help achieve greater performance.

The white paper names and explains the five design principles required for the successful implementation of an EPR scheme. These are: circularity, which prioritizes the waste hierarchy, incentivizes eco-design, and utilizes reliable measurement protocols; performance, which includes a well-defined scope, clear roles and responsibilities, and comprehensive targets that scale up over time; convenience and user-friendly systems that increase the amount of valuable resources that are collected and processed effectively; producer

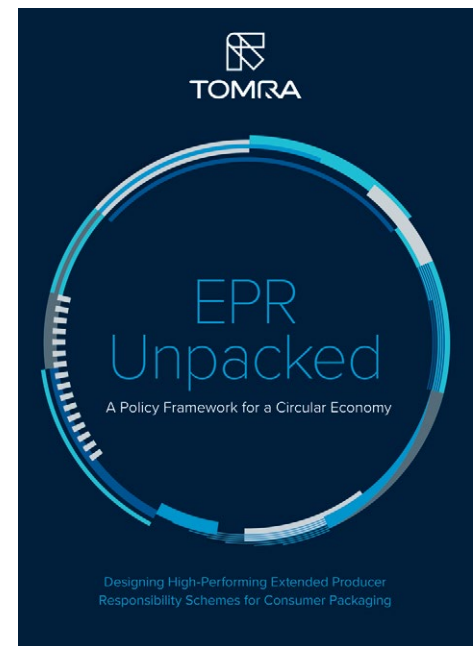

responsibility which establishes clear rules for the management of packaging waste; and finally, system integrity, which ensures transparency and compliance to support the achievement of targets.

In Asia, local initiatives have developed into cross-industry networks – a response to the fact that 80% of the plastic in the world's oceans entered them via Asian waterways.

Today, EPR is not only being applied in Europe but also in other regions. South Africa and Vietnam have recently implemented EPR for packaging, and several states within the United States are currently considering such measures.

In Europe, the robust targets defined in the 2019 Single Use Plastics Directive have resulted in almost all EU member states introducing legislation on deposit return systems for beverage containers, which will apply by 2029.

The implementation of EPR legislation is a transformative measure to improve both the quality and quantity of the resources that get recycled, thereby supporting the acceleration to a circular economy.



## New Multi-Purpose TPV with 25% Recycled Content

■ Sarlink® thermoplastic vulcanizates (TPVs) are the premier choice for critical applications that require superior elasticity and long-term performance, like extruded seals and hoses or molded gaskets. Sarlink TPVs have steadily been replacing thermoset rubber, like EPDM, in sealing applications due to improvements in processing, design, and weight reduction. In addition, unlike EPDM rubber, Sarlink TPVs are recyclable, both in-process or at the end of the product’s life cycle. Teknor Apex introduces the latest innovation in the Sarlink portfolio.

The new grade, Sarlink® R2 3180B, is based on the existing Sarlink® 3180B technology, but incorporates 25% Post-Industrial Recycled (PIR) content. This is a pre-colored black, high-durometer multi-purpose TPV, that is essentially the functional equivalent of its virgin counterpart in terms of processing and performance. Sarlink® TPVs in general have faster cycle times or throughput rates versus competitive TPV products on the market, and the addition of recycled content has proven to maintain this advantage during processing trials.

The unique use of PIR content versus Post-Consumer Recycled (PCR) content provides for a cleaner, more consistent raw material stream that can be used for extrusion processes without issue. Teknor Apex treats recycled feedstocks like prime raw materials, and they are subject to the same quality assurance testing and must meet relevant specifications for use. The use of recycled content helps to promote a circular economy while decreasing reliance on virgin fossil-based resources and energy. This allows brands to meet consumer and regulatory demands for enhanced sustainability of their products and contributes toward a lower carbon footprint by avoiding the impacts of manufacturing virgin petroleum-based materials. The Sarlink R2 3180B is just first TPV with sustainable content to launch, but softer grades and more specialty TPV formulations containing sustainable content are currently under development, to be released later this year.

Sarlink® TPVs are manufactured according to the standards of ISO-9001 in the USA, Singapore, and Belgium with strict formulation control and traceability.

► Teknor Apex Gruppe  
[www.teknorapex.com](http://www.teknorapex.com)

*The new Sarlink® R2 3180B TPV with 25% recycled content is a multi-purpose TPV containing high-quality Post-Industrial Recycled (PIR) content and processes and performs like its virgin counterpart*



### PLASTIC EXTRUSION



16-2800mm PE/PP/PPR/PVC/PVC-O/RTP  
 RTP-Reinforced Thermoplastic Extrusion Line

### RECYCLING



1000-8000kg/h Waste Plastic Washing

### HDPE BLOW MOLDING

0.5L-30L 60-300L 500-3000L



[www.beierpm.com](http://www.beierpm.com)  
[info@beierpm.com](mailto:info@beierpm.com)



BE BEIER, BE GREENER

## Agreement on the Production and Procurement of Pyrolysis Oil from Mixed Plastic Waste

■ BASF has concluded a framework agreement for the purchase of pyrolysis oil from mixed plastic waste with ARCUS Greencycling Technologies. The two companies want to contribute their respective know-how to the value chain in order to return plastic waste that is not recycled mechanically in the sense of a circular economy and reduce CO<sub>2</sub> emissions. ARCUS will supply BASF with pyrolysis oil and expand its capacities in the coming years. BASF will use the oil in its production plants as a raw material for the production of Cycled™ products.

The ARCUS process demonstration unit built in Frankfurt is the first of its kind on a commercial scale in Germany and produces pyrolysis oil from mixed plastic waste that is not re-

cycled mechanically. "With the guaranteed purchase of the oil produced, ARCUS can build further plants with higher capacity and thus make a significant contribution to closing material cycles together with BASF," said Daniel Odenthal, Chief Operating Officer of ARCUS Greencycling Technologies. The agreement foresees the take-up to be increased to up to 100,000 tons of pyrolysis oil per year.

The agreement is another building block in the expansion of BASF's ChemCycling™ business, which focuses on the chemical recycling of non-recycled post-consumer plastic waste on an industrial scale. BASF will feed the pyrolysis oil supplied by ARCUS into its production network in Ludwigshafen, replacing fossil resources. The proportion of recycled

raw material is allocated to products manufactured in the Verbund using a mass balance approach. The attribution is checked by an

independent auditor. The products that bear the name suffix "Cycled™" have exactly the same properties as conventionally manufactured products. Customers

can therefore process them in the same way and also use them in applications that place high demands on quality and performance.

➔ **BASF SE**  
[www.basf.com](http://www.basf.com)

**ARCUS Greencycling Technologies GmbH**  
[www.arcus-greencycling.com](http://www.arcus-greencycling.com)

## Market Study: Plastics

■ Plastics play a major role in the "Green Deal" that aims to make Europe climate-neutral by 2050. EU initiatives for circular economy and bioeconomy promote recycling and bioplastics, whereas plastic waste and microplastics are to be restricted. Further, Europe wants to become less dependent on oil and gas imports. Despite crises and conflicts, nearly 57 million tonnes of plastics were sold in Europe last year, around 3 million tonnes more than in 2015. This is the second time Ceresana has analyzed the entire European market for all commercially important plastics: from mass-produced standard polymers, such as polyethylene, polypropylene, PET or PVC, to high-performance plastics needed for lightweight construction and special technical applications.



**Ceresana**  
Market Research Since 2002

### The study in brief:

Chapter 1 provides a detailed presentation and analysis of the European market for plastics – including forecasts to 2031. It further examines the various application areas of plas-

tics and types of plastics are considered individually.

Chapter 2 considers 23 countries individually: Demand, revenues, production and trade of plastics. Total production and trade volumes are broken down by type of plastic. The development of total demand is reported for each type of plastic and application.

Chapter 3 provides useful company profiles of the most important European manufacturers of plastics, clearly structured by contact details, revenues, profit, product range, production sites and brief profile. Detailed profiles are provided by 114 manufacturers.

➔ **Ceresana**  
[www.ceresana.com/en/market-studies/plastics/plastics-europe/](http://www.ceresana.com/en/market-studies/plastics/plastics-europe/)



# A FEEDER THAT FITS SEAMLESSLY INTO YOUR PRODUCTION LINE WITHOUT CUSTOMIZATION?

THIS ONE WILL.



THE ALL-NEW PRORATE PLUS:  
SURPRISINGLY POWERFUL

[www.prorate.plus](http://www.prorate.plus)

K2022 | Oct 19-26, 2022  
Hall 14 Booth B19

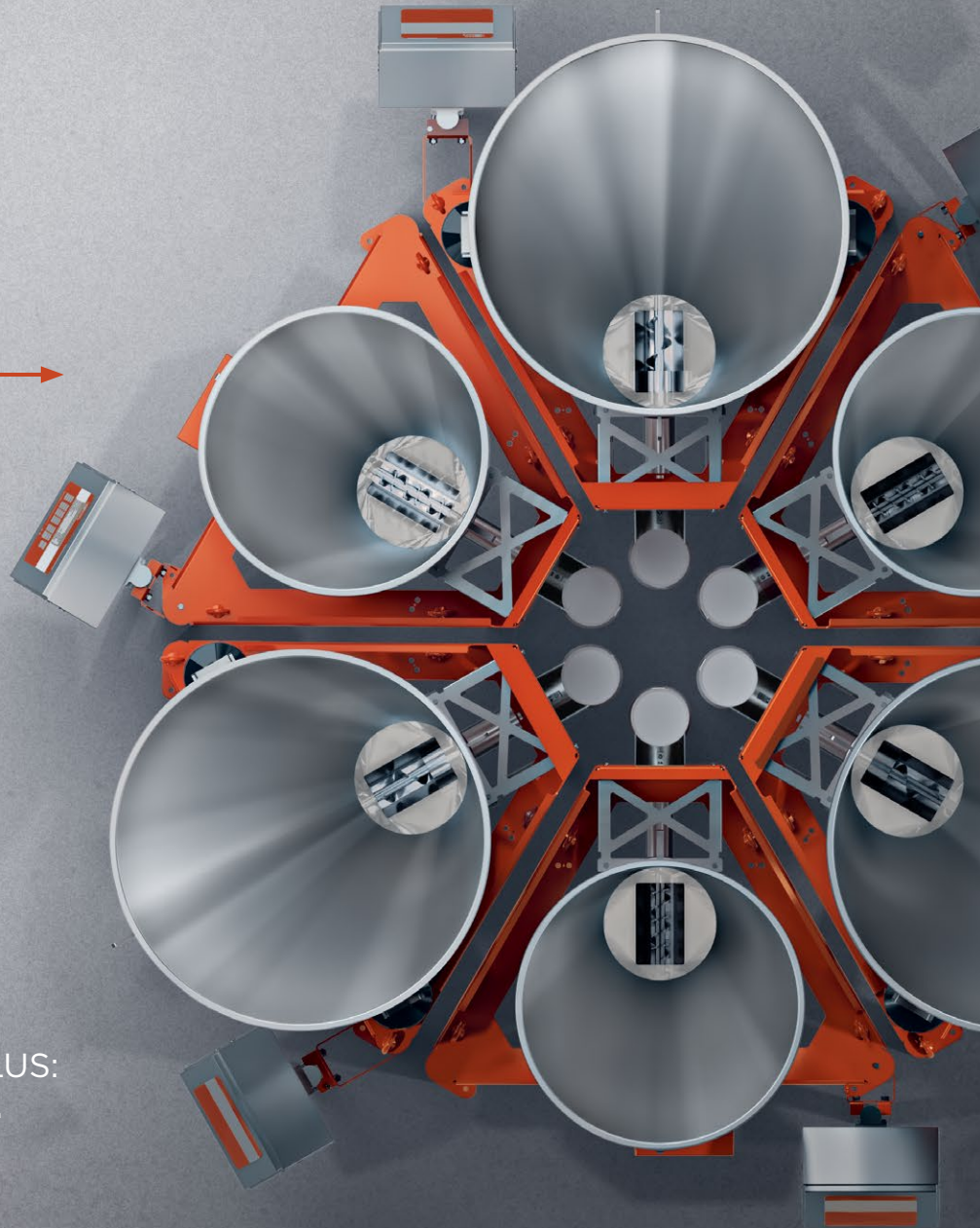



## Agreement on the Production and Procurement of Polyolysis Oil from Mixed Plastic Waste

■ Addex will introduce its integrated blown film Cooling and Stabilization System (CSS) for extrusion lines at the upcoming K 2022 exhibition in Düsseldorf, Germany. The digital, automatic bubble cage (Dcage) features Addex's "Operator-Assist" (Å) technology which controls the entire cooling process on one screen.

Addex has partnered with Pearl Technologies, Savannah, N.Y., a leading supplier of quality web guiding and handling equipment, to create a robust, "smart" bubble cage featuring Addex's proprietary 100% pure digital automatic controls. The Addex + Pearl Digital Bubble Cage provides smooth, consistent bubble diameter control and features Pearl's unique patented cage arm technology. Each cage arm is fabricated from a lightweight custom aluminum extrusion with a smooth, fully radiused active surface that always faces the bubble. Surface-modified with Pearl's SM24 "Extreme-Slip" ultra-low coefficient of friction (COF) hard-coat material, the resulting design offers long wear life and superior quality film without blemishes, tracks, or chatter marks.

Addex has engineered control over stepper motors to perform precise repeatable axis adjustment for vertical positioning of the cage, as well as the horizontal adjustment for bubble diameter integrated with their all-digital IBC Control System (DIBC).

Addex's bubble cage system represents a breakthrough in the blown film industry. The company's depth of process knowledge coupled with a strong desire to make operator-friendly equipment was the impetus behind the "smart" Bubble Cage + DIBC and the resulting Å - Operator Assist technology. Additionally, all the system components are service friendly, allowing remote maintenance-friendly diagnoses/troubleshooting, thus avoiding delayed and costly in-person technical service calls.

The Bubble Cage and DIBC system are "smart" because they enable a processor to "set it and forget it," according to Bob Cree, President of Addex Inc. Upon startup, the operator loads a previously memorized setpoint and the Dcage + DIBC automatically adjust themselves, making for faster, greener changeovers, freeing the operator to focus attention elsewhere. Setups are saved in the system, and once selected, DIBC sensors are linked with the digital cage positioning. If the system sees the bubble coming too close, it won't allow the cage to come in too tight. It digests all inputs before operation, ensuring success for every operator regardless of experience.

Addex's Digital IBC Control (DIBC) uses patented, split, fully-digital ultrasonic sensors that eliminate errors caused by interference common to other systems and enable the air flow intake and exhaust to react to the slightest change in bubble size. This occurs while retaining high precision and accuracy over the resulting bubble size. Additionally, a digital stepper motor valve control retains this high degree of precision to ensure tighter control over the entire process, as well as repeatability.



Also new to the Addex lineup and displayed as part of the Digital Bubble Control System is Short Stack Intensive Cooling, the latest iteration of Addex's patented Intensive Cooling technology. Short Stack is an enclosed two-level, stacked Intensive Cooling system that guarantees 15% to 20% output gains with low-melt strength materials that typically are impossible to run on other raised-up cooling systems. Short Stack also provides up to 50% output gains with easier to run, high-melt strength materials. The Short Stack stabilization and bubble cooling immediately upon exit of the die is the key to impressive output gains while maintaining film quality through enhanced bubble stability. Short Stack Intensive Cooling also features digital control over that portion of the cooling process, including Å-Operator Assist technology and remote maintenance capability.

Addex's CSS system also includes quality-enhancing gauge control, provided by the Addex EGC (External Gauge Control) Intensive Cooling auto-profile air ring, which sits atop the Short Stack and controls 100% of the

airflow to the air ring. Fully digital, very high resolution of the control is assured by a multitude of control zones that can be moved to any "in" or "out" position within each channel. Addex's proprietary mapping software processes the raw profile input from several profiler options, including the Kundig K-500 Rotamat KT thickness measuring system (showing at K 2022), plus all other Kundig and NDC profiling options. The mapper combines profiler signals with feedback from reversing haul-off position and nip roll speeds to achieve 1-degree film profile mapping, producing best-in-industry twist and turn compensation due to Addex's sophisticated mapping.

Kundig rotomat mounting points are included standard, providing excellent stability support for the bubble which stays on center for better quality profiles and enhanced film quality. "By stabilizing the bubble near the sensors' profiler, everything gets better because the bubble is not moving around," says Cree. "This eliminates the spikes, dips, and high points that aren't real, but a consequence of bubble motion; this smart bubble cage stabilizes the bubble and makes the profile quality better to begin with."

The Addex Cooling and Stabilization System comes ready-to-install, using just two connection types – power and ethernet – which interconnect the system in a simple way. A mini-control panel can control just the cage or optionally be expanded to integrate the DIBC, EGC, and Short Stack together. Addex's pre-engineered solution for installation minimizes downtime, requiring only a four-point mount to install. The company reports that retrofits with the Digital Bubble Control System, including operator training, can be accomplished in as little as two days if mounting points are pre-installed. This automation of a blown film line can be retrofitted to older lines, giving customers the best value for their investment - with standard delivery times running 14 to 16 weeks.

"The biggest advantage of this fully-integrated system approach to bubble control is the support it provides operators, especially those less experienced, thereby ensuring experienced results," said Cree.

► **Addex Inc.**  
[www.addexinc.com](http://www.addexinc.com)  
 K 2022: Hall 17/C41

## Investment in Indiana Recycling Expansion

■ The Plastics Industry Association (PLASTICS) President and CEO, Matt Seaholm, commended Novolex, in response to an announcement of a \$10 million investment to expand recycling of plastic bags and other polyethylene film at its recycling facility in North Vernon, Ind.

"Today's announcement by Novolex is great news for the circular economy," said Matt Seaholm, President and CEO of PLASTICS. "Not only will this investment create jobs for the community, but expanding recycling capacity, especially in flexible films, is very much needed; we applaud their commitment to future growth in recycling. The PLASTICS industry is investing billions of dollars into recycling technology and continues to find solutions to make it easier for consumers to recycle more material, keeping valuable plastic in the economy instead of in a landfill."

The investment in mechanical recycling will enable Novolex to produce up to 28 million pounds of recycled content, per year, to create new products made with post-consumer recycled content. The state-of-the-art equipment chosen for the expansion will be able to identify and sort a wide range of incoming materials such as plastic bags, pallet wrap, agricultural film and more, providing important flexibility in the range of potential incoming feedstocks. At full capacity, the plant will utilize up to 40 million pounds of polyethylene waste that will be diverted from landfills each year.

► **Novolex**  
[www.novolex.com](http://www.novolex.com)  
 The Plastics Industry Association (PLASTICS)  
[plasticsindustry.org](http://plasticsindustry.org)

HELP WANTED

**Title: Technical Sales Engineer**
**Position reports to: Sales Manager**

**Objective:** Promotes **Guill** as a world-class leader in extrusion tooling design and manufacturing. Maximize market share and expansion through knowledge based sales techniques. Educates clients about the advantages of **Guill** design features and is regarded as an extrusion knowledge resource for customer inquiries. Provides seamless interaction between **Guill** and clients throughout the sales process. Prospects for new customers through networking, web searches, cold calling, trade-show attendance and customer visits.

**Responsibilities:**

- Gathers all pertinent technical information about potential customers' process, products, equipment and project goals in order to accurately design and price new projects.
- Prepares and delivers technical presentations and overviews for sales and marketing departments.
- Reports results of customer, prospect and suspect contacts and forecast expected sales.
- Represents **Guill** and conducts business with honesty and integrity.
- Follows up on active quote projects and converts to orders.
- Follows up on shipped projects to ensure customer satisfaction.
- Provides telephone sales coverage as required.
- Attends final design review meetings on projects.
- Insures customer service satisfaction as well as protecting **Guill's** best interest.
- Acute attention to detail and relentless follow through, in the pursuit of company goals and objectives in terms of delivery, accuracy and profitability.
- Maintain travel expenses within allowable company budget.
- Participate in the goal setting and evaluation process for your own territory and the division.
- Log all sales contact information and correspondence through the **Epicor** database.
- Provide input to upper management on current market trends and suggest tactical response.

**Education & Experience Requirements:** A.S or B.S. degree in plastics or mechanical engineering with 5 years of project management or direct sales experience.





**KNOWLEDGE/SKILLS/REQUIREMENTS:** Must be authorized to work in the United States. Must be skilled with **Microsoft Suite, email, calendar and communications. Reliable and responsible.**

**BENEFITS:** Health. Dental. Life Insurance. PTO Time. Holidays. 401K Retirement Plan/Match up to 3%.



**Guill**

Guill Tool & Engineering, Co., Inc.  
 P: 401.828.7600 C: 401.304.5797  
 hr@guill.com www.guill.com  
 10 Pike Street, West Warwick, RI 02893



## “MEDD”ical Extruder Aids Impossible

■ For Vesta Thermoplastics, a Lubrizol Life Science Health (LLS Health) Company, extruding the impossible is a daily endeavor. However, Davis-Standard’s extruders have risen to the challenge. Vesta, a leading supplier of tight-tolerance extrusions for the medical industry, recently installed a Davis-Standard MEDD extruder to augment the company’s existing Davis-Standard HPE extruders. The MEDD has helped Vesta increase productivity, alleviate potential backlogs and address shorter lead times for the company’s diverse portfolio of thin-wall tubing, multi-lumen, and coextrusion products. This includes tubing and devices that support single-use and long-term implantable applications such as neurostimulation, feeding and drainage tubes, catheters, and vascular loops.

“We’ve had a lot of success with our HPE extruders, and the MEDD has been a welcomed addition. We bought this machine during 2022 MD&M West since the show is only 30 minutes from our facility, making delivery very convenient,” explained Steven Mayol, Senior Process Engineer at Vesta Thermoplastics. “Installation went smoothly and the MEDD is already proving to be a good investment. Being able to exchange barrel

sizes when necessary and having the capacity to run a variety of high-temperature polymers is essential to our business model. We pride ourselves in delivering extrusion tubing that no one can challenge, including extrusions that involve new polymers.”

The MEDD’s interchangeable barrel assembly, ease of maintenance, and operator accessibility have been notable for Vesta. This design is specific to clean room environments, providing a replaceable feed section liner and direct drive technology for bottom line efficiency and materials flexibility. Stainless steel surfaces, quick change capabilities, and a broad polymer range enable the tubing consistency and reliable performance Vesta needs to serve current and emerging medical markets. Vesta’s innovation encompasses lead tubing, balloon tubing, custom extrusion, PEEK extrusion, braided tubing, striping and multi-layer coextrusion, multi-lumen, heat shrink tubing, rapid and bump extrusion.

Mayol also appreciates Davis-Standard’s personalized approach to service. “Davis-Standard has been exemplary with timely, customer-centric service. Their troubleshooting support has also been helpful whenever we’ve needed it,” he said.



*Employee working with the Davis-Standard MEDD equipment in the Vesta Thermoplastics facility*

“This includes designing the right feedscrews for our polymer range to address targeted outputs with excellent melt quality and product consistency.”

➔ **Davis-Standard, LLC**  
[www.davis-standard.com](http://www.davis-standard.com)  
[www.lubrizol.com/Health/Medical/Device-Contract-Manufacturing/Medical-Device-Manufacturing-Capabilities/Medical-Extrusion](http://www.lubrizol.com/Health/Medical/Device-Contract-Manufacturing/Medical-Device-Manufacturing-Capabilities/Medical-Extrusion)

## Production at World-Class Clarifier Plant Launched

■ The recent launch of production at Milliken & Company’s impressive, new clarifier plant in Blacksburg, South Carolina, will enhance access to the Millad® NX® 8000 additive for customers worldwide. This facility will enable Milliken to meet increasing demand for these products well into the future.

“We’re pleased to report that the plant has begun manufacturing product, and we plan to reach full operating capacity by the end of 2022, allowing us to increase Millad production by 50 percent,” said Cindy Boiter, president of Milliken’s Chemical Business. Announced earlier this year,

“this represents the largest clarifier plant investment in Milliken history.”

Millad NX 8000 helps reduce carbon emissions by enabling converters to lower their energy use during processing while also improving production efficiency. This has never been more important than during this period of unparalleled spikes in energy prices. Additionally, these certified energy savings allow brand owners using PP clarified with Millad NX 8000 ECO to display the much-desired UL Environmental Claim Validation label on their injection-molded parts.

Boiter went on to recognize the impressive efforts that went into mak-

ing this plant opening a reality. “We greatly appreciate all the efforts of our associates who were involved in making this plant exceptional.”

Milliken has long been known for its innovation, collaboration and commitment to advancing sustainability. Recognized as one of the “World’s Most Ethical Companies” by Ethisphere Institute for 16 straight years, the firm leverages its 157-year history and extensive chemical expertise to tailor products that make the world a better place and create a healthier future for generations. Millad NX 8000 is an excellent example of applying inno-

vation through chemistry to advance sustainability.

Polypropylene (PP) is durable, lightweight, highly recyclable and, thanks to Millad, offers glass-like clarity. This improvement enables PP to be used in applications such as thin-wall packaging. It also is one of the least energy-intensive polymers to make and recycle compared to other clear polymers. Additionally, the How2Recycle® labeling program in late July upgraded the eligibility of rigid PP tubs, bottles, jugs, and jars to “Widely Recyclable” in the United States.

CO<sub>2</sub> reductions based on reduced cycle time and energy usage are highly dependent on energy source.

➔ **Milliken & Company**  
Milliken.com



*Milliken begins production at world-class clarifier plant.  
(Photo © 2022 Milliken & Company)*

## Plastics Industry Association Bioplastics Innovation Award

■ The Plastics Industry Association (PLASTICS) announced sustainable technology company, Anellotech, as the winner of PLASTICS’ 2022 Innovation in Bioplastics Award. The announcement came as part of PLASTICS’ annual, online #BioplasticsWeek awareness and education event.

Anellotech won the award in recognition of the development of the first PET (polyethylene terephthalate) bottle made entirely from loblolly pine and other biomass feedstocks, potentially lessening the industry’s reliance on petroleum and natural gas as feedstocks. PET is a widely used plastic most commonly seen by consumers in plastic beverage bottles.

According to Anellotech, their product will enable the plastics industry to use the same plastic materi-

als used today while producing them from sustainable biomass resources, dramatically improving the sustainability of the plastics industry.

“I am honored to accept this award on behalf of the employees of Anellotech,” said David Sudolsky, CEO of Anellotech. “We’re excited to join our Bio-TCat Process development partners, IFP Energies nouvelles and Axens, as well as our strategic partner Suntory, in creating new routes to sustainable plastics.”

Anellotech’s patented Bio-TCat™ technology converts biomass into benzene, toluene and xylene (including paraxylene used in making PET), which are chemically identical to their petroleum-based counterparts and result in a product with 70% lower greenhouse gas emissions than petroleum-based PET.

“PET is the most recycled plastic and enjoys a lower comparative carbon footprint than metals or glass in most applications,” said Patrick Krieger, Vice President of Sustainability at PLASTICS. “Producing with renewable feedstocks only improves the sustainability of the material and puts the industry a step closer to realizing a more circular plastic economy.”

A formal presentation of the Bioplastics Innovation award will be made at the PLASTICS RelFocus Sustainability & Recycling Summit, to be held in Minneapolis in May of 2023.

➔ **The Plastics Industry Association (PLASTICS)**  
[www.plasticsindustry.org/innovation-bioplastics-award](http://www.plasticsindustry.org/innovation-bioplastics-award)

## New Member of Board of Directors

■ Nordson Corporation announced the appointment of Dr. Milton Morris, recently retired president and chief executive officer of Neuspera Medical, Inc., to its board of directors. Dr. Morris will bring robust business leadership experience, as well as a legacy of successful product innovation, to the board.

“We are pleased to welcome Milton as a new independent director. His passion for innovation and new product development aligns well with Nordson’s strength of understanding customer needs and bringing diversified precision technology solutions to market. In addition, his professional background in medical devices will enhance our understanding, as Nordson plans to further expand acquisitively in this exciting space. We look

forward to bringing Milton’s perspective to the board,” said Michael Merriam, chair of the board of directors, Nordson Corporation.

Throughout his career, Dr. Morris has demonstrated a passion for product development that improves people’s lives. He has also led decentralized organizations, growing successful businesses and cultivating diverse and inclusive talent pipelines.

“I look forward to partnering with the Nordson board of directors and executive management team. The company is making solid progress on its Ascend strategy to achieve top tier growth with leading margins and returns. I am excited to reinforce their strong commitment to innovation while also sharing my unique perspec-



*Dr. Milton Morris*

tive from the medical device industry,” said Dr. Morris.

Dr. Morris’s appointment brings the number of Nordson directors to nine, following the departure earlier this year of Arthur George, who served on Nordson’s board for ten years. Dr. Morris will serve on the board’s audit committee immediately upon appointment.

## Vice President, Treasury and Finance Appointed

■ Nordson Corporation also announced that Anand Patel will succeed Ray Cushing as vice president, treasury and finance following Ray’s upcoming retirement. Anand joined Nordson on September 26 from O-I Glass, Inc., a global manufacturing company, where he served as vice president and treasurer. He has held roles of increasing responsibility at O-I since 2013, and prior to that he was a senior manager at Deloitte Tax LLP for nine years.

Joe Kelley, executive vice president, chief financial officer, said, “We are looking forward to welcoming Anand to Nordson’s finance team. His expertise and experience gained throughout his professional career with large, global manufacturing organizations will serve him well in supporting Nordson’s next chapter of profitable growth.”

Anand succeeds Ray Cushing, who plans to retire at the end of the calendar year after 42 successful years with the company.

Joe Kelley said, “On behalf of the entire Nordson finance team, I’d like to thank Ray for his outstanding financial stewardship of the Company. Ray successfully shepherded Nordson’s treasury function from supporting a \$200 million revenue business to a business with revenue of greater than \$2.5 billion. That is an incredible accomplishment and one that he can take great pride in as he moves on to his next chapter in retirement.”

## Additional \$500 Million for Share Repurchase Program Authorized

■ Nordson Corporation announced that its Board of Directors has authorized the repurchase of up to an additional \$500 million of the Company’s outstanding common shares, adding capacity to the \$160 million remaining from its 2018 Board authorization.

“The Board’s action reflects continued confidence in the execution of our Ascend strategy, designed to deliver top-tier growth with leading margins and returns,” said Nordson Executive Vice President and Chief Financial Officer Joseph Kelley. “Consistent cash generation is a strength of our business. We are pleased to return this value to

our shareholders through annual dividends and disciplined share repurchases, particularly in this dynamic environment. We also will continue making investments to fund long-term organic and acquisitive growth opportunities.”

Shares may be purchased from time to time at prevailing prices, subject to market conditions, share price and other considerations. Purchases will be made on the open market pursuant to the applicable Securities Exchange Act Rules and will be funded from operating cash flows.

Nordson Corporation is an innovative precision technology company

that leverages a scalable growth framework through an entrepreneurial, division-led organization to deliver top tier growth with leading margins and returns. The Company’s direct sales model and applications expertise serves global customers through a wide variety of critical applications. Founded in 1954 and headquartered in Westlake, Ohio, the Company has operations and support offices in over 35 countries.

► Nordson Corporation  
www.nordson.com



## Clean-Up Event

Members of the Plastics Industry Association (PLASTICS), working in conjunction with RiverLink, an Asheville-based conservation organization, participated in a clean-up event at River Bend Park along the Swannanoa River. The event is a collaboration between RiverLink through the Community Impact Task Group of PLASTICS' Future Leaders in Plastics Committee (FLiP) – a professional development initiative for plastics professionals under the age of 40. FLiP's mission is to foster collaboration, providing an outlet to give back and positively impact the environment and communities in which the plastics industry serves.

"PLASTICS is here to demonstrate our commitment to the environment, promote the environmental benefits of using plastic responsibly, and encourage legislators to do all they can to fund recycling infrastructure that will help protect beautiful places like this," said Leslie Jutte, PLASTICS staff liaison for FLiP and director of the association's Material Suppliers Council. "We love plastic – we hate plastic waste."

Working with the RiverLink team and utilizing materials and equipment provided by the non-profit,



approximately 50 PLASTICS' members spent several hours removing litter in support of RiverLink's goal of promoting the environmental and economic vitality of the French Broad River and surrounding waterways.

"The plastics industry isn't just companies, it's people all over the country who care about the communities where we live and work," said Jon Smalling, National Sales and Marketing Manager at BAUMÜLLER and member of the FLiP Community Impact Task Group. "It's an honor for us to do some good for the local environment while we're guests here in Asheville."

"As a local non-profit working for the past thirty years to promote the

environmental and economic vitality of the French Broad River and its watershed, we're grateful to work with a diverse group of volunteers each year on projects that benefit our waterways and public lands," RiverLink said in a statement. "Removing litter from Riverbend Park along the Swannanoa River, one of the French Broad's largest tributaries, is one of many ways we can steward this special place and connect volunteers from groups like the Plastics Industry Association with the areas we care about."

➔ **Plastics Industry Association (PLASTICS)**  
[www.plasticsindustry.org](http://www.plasticsindustry.org)

## Global Sustainability Initiative Launched

Davis-Standard announces the formation of a global sustainability initiative that prioritizes resource conservation, and supports circular economy initiatives, social responsibility, and business collaboration. As a company, Davis-Standard is accelerating efforts to cultivate best practices and machinery innovation that aligns with United Nations (UN) sustainable development goals.

"We have a collective responsibility to provide technology that enables forward-thinking solutions to complex challenges such as food security, reliable energy sources, and strategic infrastructure," said Giovanni Spitale, Davis-Standard CEO. "We have prioritized sustainability efforts along with safety, quality, and productivity to address the

needs of our customers while playing an active role ourselves. As a result, we have already made significant advances in our machinery development regarding reduced waste, energy efficiency, and increased recyclability. We look forward to doing more as we work toward a sustainable future."

Davis-Standard has committed to the following objectives by the year 2025:

- Direct R&D funding, targeting five percent of sales revenue, toward sustainable equipment development. Efforts will focus on further expanding customer use of recycled content, reducing material waste, and efficient use of energy and process structures to support the circular economy.
- Increase procurement of carbon pollution-free electricity to 100 percent



of Davis-Standard's total energy usage.

- Host "Davis-Standard Community Days" to support every community in which Davis-Standard is located. Each facility will identify and complete two environmentally-conscious activities per year.
- Achieve ISO 14001 certification at all of our global facilities.

➔ **Davis-Standard, LLC**  
[www.davis-standard.com](http://www.davis-standard.com)  
[www.davis-standard.com/sustainability/](http://www.davis-standard.com/sustainability/)

## 2022 Size and Impact Report: PLASTICS Moves to America's 6th Largest Manufacturing Industry

■ The Plastics Industry Association (PLASTICS) unveiled its 2022 Size and Impact report, the association's flagship annual analysis of the plastics industry's contribution to the U.S. economy.

Dr. Perc Pineda, Chief Economist at PLASTICS, presented an overview of the report's findings during an online Executive Briefing provided to PLASTICS members and members of the press.

Highlights shared during today's briefing include:

- The U.S. plastics industry accounts for nearly a million jobs (999,100); when suppliers to the plastics industry are included, that number rises to 1.5 million.
- Plastics manufacturing employment grew 3.2% from 2020 to 2021, more than twice the growth of manufacturing as a whole (1.5%).
- U.S. plastics shipments totaled \$468.0 billion for 2021; when suppliers

to the plastics industry are included, shipments totaled \$600.4 billion.

"Today's report shows that the plastics industry, while previously eighth is now the sixth largest manufacturing industry in the U.S.," said Matt Seaholm, President and CEO of PLASTICS. "Plain and simple, these numbers show that the PLASTICS industry is growing and will continue to do so as part of a circular economy. Plastic is remarkable – It saves energy by being lightweight. It saves resources by being efficient to manufacture and transport, and it saves lives through protective gear, medical devices, and so much more. The PLASTICS industry is proud of our people and our products."

"The plastics industry continues to develop new technologies that improve the manufacturing process to include more recycled content, less ma-



Dr. Perc Pineda

terial, design for recyclability, and improved performance to better protect things like food and beverages, greatly reducing waste," concluded Seaholm.

➔ **Plastics Industry Association (PLASTICS)**  
[www.plasticsindustry.org](http://www.plasticsindustry.org)

## New Nofia® FR Grade Introduced

■ FRX Innovations has announced the launch of a new product line which extends the performance range of the company's Nofia® copolymer flame retardants for the consumer electronics and appliance industry. Nofia CO6010-EX is the first in a new line of advanced copolymeric flame retardants designed to expand the capabilities of the Nofia family and remove the need to dry the polymer before processing.

Nofia CO6010-EX polyphosphonate fills a gap in the current portfolio by targeting a growing need for PC, PC/ABS, and PC/ASA in applications where neither brominated flame retardants or perfluoro butyl sulfonates can be used. In addition to no pre-drying of the polymer, this new range has much lower initial color. The exceptional heat distortion and physical properties of Nofia flame retardants have long been desirable in UL94 V0, or VTM-0 formulations, but now processing

is simpler, impact resistance is improved, and the new material offers the ability to meet the bluer shades of white required for certain brands of electronic equipment and electrical appliances. Like other Nofia FRs, Nofia CO6010-EX provides improved resistance to chemical cleaners and permanence when compared to traditional, non-polymeric, phosphorous-based flame retardants.

"Polycarbonate has been a polymer of high interest," said Marc Lebel, CEO of FRX Innovations. "This is due to restrictions announced in Europe and the U.S. on the future use of brominated FRs in enclosures for TVs and monitors, and the high probability that those restrictions will soon be broadened to enclosures for most indoor electrical equipment."

There have also been added concerns about per- and poly-fluorinated additives, so-called "Forever Chemicals." The commonly used

flame retardant KPFBs is one such chemical, and already brand owners and OEMs are looking for alternatives, according to Lebel. He added that non-halogen composition is only part of the story. "Polymeric additives such as Nofia are inherently safer than smaller molecules, and being polymeric is at the heart of why Nofia products offer such enhanced physical properties," said Lebel.

FRX is developing other products based on similar technology to Nofia CO6010-EX. Beyond their use in polycarbonate and PC blends, future grades will offer enhanced properties for other polymers, such as polyesters, and the opportunity for inherently flame-retardant resins with low color transparency and achieving VTM-0 at 0.075mm.

➔ **FRX Innovations**  
[www.frx-innovations.com](http://www.frx-innovations.com)



# SMART EXTRUSION

**THE SPECIALIZED WEBPORTAL  
ON EXTRUSION  
FOR EVERY MODERN NEED**



**VM** Verlag GmbH  
Cologne, Germany



[www.smart-extrusion.com](http://www.smart-extrusion.com)



# K 2022 – *Official Special Show "Plastics Shape the Future" Focuses on the Hot Topics Climate Protection, Circular Economy and Digitalization*

Every three years, and this coming autumn again, the world of plastics meets in Düsseldorf: The world's leading trade fair K 2022 presents new products and innovations from all sectors of the industry – from production to processing, to mechanical engineering. Once again, the central point of contact for the critical exchange of information, thoughts, and opinions is represented by the Special Show „Plastics shape the future“ in hall 6. The focus of the special show

under the auspices of Plastics Europe Deutschland (PED), the plastics producers' association, and Messe Düsseldorf will be on the three groundbreaking hot topics of K 2022: climate protection, circular economy, and digitalisation.

In entertaining formats, high-level guests from the world of politics, science, and the industry, as well as NGOs will share information about and discuss economic, social, and environmental challenges and solu-



October 19 – 26, 2022,  
Düsseldorf, Germany  
[www.k-online.de](http://www.k-online.de)

tions around the leading themes of K 2022 – thus connecting the trade fair presentations of the companies with the societal agenda of K.

The special exhibition will enrich the extensive and socially highly relevant exhibition offering of K 2022.

## Plastics Expertise and Innovative PET Recycling for High-Quality Products

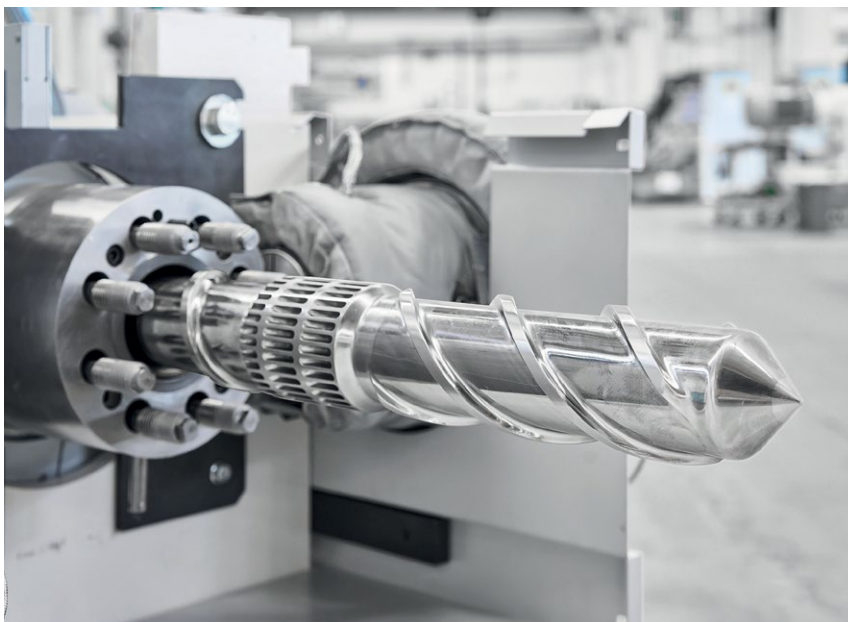

As a sub-exhibitor of Oerlikon, BB Engineering will present itself as an expert in extrusion, mixing and filtration as well as an innovator for PET recycling with the VacuFil and VarioFil R+ systems at the K.

### Plastics competence – extruders, mixers, filters

BB Engineering is no newcomer to the plastics industry. As a joint venture of Brückner Maschinenbau (leading with film extrusion lines) and Oerlikon Barmag (leading with man-made fiber spinning lines), BB Engineering took over the extruder division of Oerlikon Barmag already in 2002. BB Engineering can thus draw on more than 60 years of experience in extruder construction and is constantly engaged



in development work to further optimize its products. To date, approx. 20,000 extruders have been delivered worldwide. The extruders are mainly used in film and synthetic fiber spinning lines for PP, PET, PA and PE. BB Engineering is the exclusive supplier for its parent companies and also sells extrusion and filtration technology to third party customers. The portfolio also includes various continuous and discontinuous polymer filters from small to large (0.1 to 40m<sup>2</sup> filter area) as well as various polymer mixers.

The quality of the melt and thus of the end product is BB Engineering's top priority for all components and equipment. "Our company has always stood for high-quality, durable machines and components that enable our customers to manufacture first-class products. A high-quality melt is crucial for trouble-free production and good, consistent product properties" underlines Dr. Klaus Schäfer, Managing Director.

**Recycling technology**

BB Engineering has been focusing its development work increasingly on recycling technologies for several years. In addition to extruders, filters and mixers that are suitable for both recycling processes and the processing of recycle, BB Engineering offers a complete PET recycling plant called VacuFil.

With VacuFil, BB Engineering has developed an innovative and unique PET LSP recycling process. And here, too, the focus is on product quality. The process combines gentle large-scale filtration and targeted IV regulation for consistently outstanding rPET melt quality. Thus, much more than simple "downcycling" is possible with VacuFil. VacuFil processes a wide range of input materials - post-production and post-consumer. The patented key component Visco+ vacuum filter removes volatile impurities quickly and reliably. VacuFil is a modular system that can be designed for different recycling applications. There are no limits to the downstream processes. Simple granulation is possible, but also direct feeding into further processing, e.g. in the synthetic fiber spinning mill. BBE offers VacuFil in combination with its own VarioFil compact spinning plant to produce polyester yarn.

**Open House**

Exactly this process can be visited during the K show at an open house of BB Engineering and Oerlikon Barmag. Not far from Düsseldorf, at the company's site in Remscheid, BBE and Oerlikon Barmag will open their doors and give customers and interested parties an insight into the technical center. Here, visitors can experience the VacuFil Visco+ recycling technology in operation with a connected VarioFil spinning plant and see live how high-quality recycling yarn is produced from PET waste.

BB Engineering GmbH  
www.bbeng.de

K 2022: Hall 1, Stand D10

**PIXARGUS**

**IN SPECT MORE**

Surface.  
Geometry.  
All-In-One.

Optical Inline Inspection of Extruded Products

Small-budget solutions

Visit us:  
**Hall 10/F28**  
19-26 October 2022  
Düsseldorf · Germany

www.pixargus.com

# Successful Extruder Now Also Available in Size 45

Next-generation extruders from battenfeld-cincinnati have long since established themselves in the market. High output rates at low screw speeds, effective melting performance with low melt temperatures plus a reduced pressure profile and consequently less wear on machines – these are the benefits provided by the high-speed soLEX NG series. In time for the coming K trade fair, the extruder specialist is now rounding off this series downwards by adding a new soLEX NG

45 to the four existing models soLEX NG 60, 75, 90 and 120 mm.

This latest and smallest model, soLEX NG 45, just like the larger models of the series, has a processing unit consisting of an internally grooved barrel combined with a matching screw geometry. The process technology advantages resulting from this combination ensure an extra-high-quality standard for the extruded semi-finished product. When processing HDPE, these extruders also achieve a 25 % higher out-

put and for PP even of up to 40 %. And in addition to that with reduced melt temperatures of about 10 °C below those in conventional extruders.

Another advantage resulting from the innovative processing unit of the NG series is the reduction in energy consumption, which is around 15 % lower than the previous soLEX series. Consequently, this successful series offers advantages not only in terms of process technology, but in terms of higher energy efficiency as well.

## *Pulsation-Free Passage Through the PVC Die*

*At K, battenfeld-cincinnati will provide information about Steady flow, an additional module to minimize pulsation in PVC extrusion, thus ensuring continuous, even output performance and consequently reliable high quality in semi-finished products. The patent pending new software module is already in use by several customers and achieves excellent results. Steady flow is one of the modules from battenfeld-cincinnati which optimizes production equipment in the era of Industry 4.0, and facilitates its operation and handling.*

In PVC processing with counter-rotating twin screw extruders, pulsations of the material flow are unavoidable. These fluctuations are caused by the C-shaped chamber profiles formed by the pair of screws. Especially when producing small throughput, for example in the production of small technical profiles, the fluctuations are more significant. This is why the extrusion specialist battenfeld-cincinnati has now developed the module Steady flow, which harmonizes these fluctuations and thus ensures a constant material discharge. For this purpose the melt pressure in front of the extrusion die is measured continuously, and the screw speed during each screw rotation is constantly re-adjusted on the basis of the measured pressure fluctuations. The software

includes a learning function, which automatically calculates optimal parameters for the compensation of pulsation during the first production run with any new products or new materials. The screw speed correction parameters identified are saved in the product recipe and thus remain available for every new production start-up. Pressure fluctuations are substantially reduced with the result of a low-pulsation melt flow passing into the forming die. The final results are

better semi-finished product quality with fewer dimensional fluctuations and consequently optimal utilization of the material.

Steady flow can optionally be integrated into the BCtouch UX control system of every new PVC extrusion line. But it can also be retrofitted without any problems in existing lines with a modern control system from the UX series.

► battenfeld-cincinnati  
www.battenfeld-cincinnati.com

K 2022: Halle 16, Stand B19,  
FG-CE12

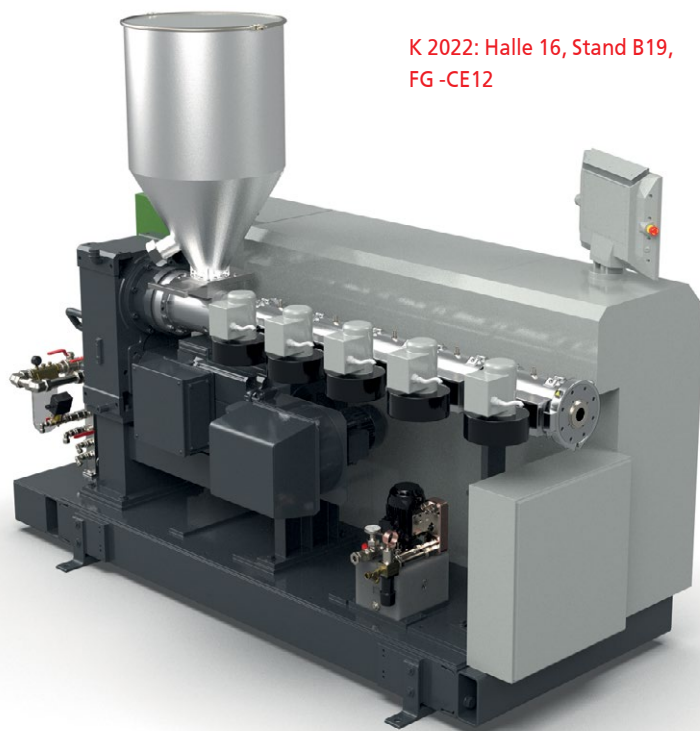



# Cutting-Edge Solutions in Rubber and Plastics Processing

Since more than 130 years, TROESTER stands for outstanding quality Made-in-Germany when it comes to developing and manufacturing innovative and reliable machines for the rubber industry. In the world of rubber and plastics processing, TROESTER is known for its flexible responses to customers' requirements and collaborates with them to produce high-quality, tailor-made solutions.

TROESTER extrusion lines provide the flexibility and precision needed to produce the highest quality with the greatest degree of operational reliability and longevity. It is this

dedication to superior quality that has become synonymous with TROESTER, making their complete lines another example of sustainable technology made in Germany.

In addition to its core products, TROESTER also meets the challenges of the market by continuously developing its portfolio. One example, the gear extruder (known as the ROTOMEX) for straining rubber compounds.

A big advantage of the TROESTER ROTOMEX is the low temperature increase of the filtered compounds. Additionally, it can be easily placed in front of another extruder or injection molding machine, linked by an integrated product control loop, it feeds the downstream equipment to exact needs. This allows the ROTOMEX to be seamlessly connected to other processes.

X-Compound, a company of the TROESTER Group, presents its technology for the compounding of challenging materials. X-Compound's Continuous Kneader technology is able to push boundaries in the production of sensitive blends and highly filled compounds. Thus, de-

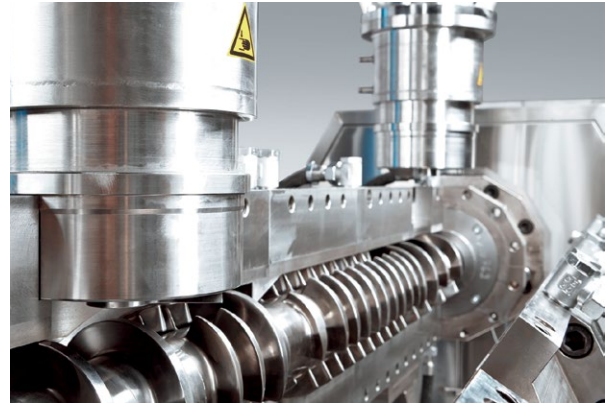

Continuous Kneader (© X-Compounds)

manding processes can be realized in a highly efficient way.

X-Compound's Continuous Kneaders are the benchmark for the preparation of e.g. cable compounds (HFFR, PVC, Semicon, XLPE). The production of very highly filled compounds for the manufacture of high-quality flooring and masterbatches are also core applications of this technology.

X-Compound also applies its comprehensive know-how to the conception, planning and construction of complete plants and is a respected engineering partner in this field.

Rotomex ZXNeo (© TROESTER)



➔ TROESTER GmbH & Co KG  
[www.troester.de](http://www.troester.de)  
 K 2022: Hall 16, Stand F40

▶ **Stepping up the game in stretch film production: PowerCast XL with a brand new triple turret winder**



EXTRUSION LINES – ENGINEERED TO PERFORM ▶

Extrusion lines – engineered to perform



▶ **DAILY LIVE DEMONSTRATION**  
runs at 11.00 a.m. and 2.00 p.m.

▶ **Hall 17 / C42 & C39**



▶ **DAILY LIVE DEMONSTRATION**  
runs at 11.00 a.m. and 2.00 p.m.

[www.sml.at](http://www.sml.at)

# A First Glimpse of the Topics, Activities and Highlights Provided at K 2022

**K**2022 in Düsseldorf is approaching fast, and preparations are in full swing. 13 June, EREMA Group and Borealis invited representatives of the international plastics and recycling trade press to Upper Austria for a sneak preview of the technological developments and lighthouse projects that the companies will present at K 2022. The venue for the pre-K event was EREMA Group headquarters in Ansfelden.

"Our mission 'Another life for plastic, because we care', is also our tagline at this year's trade fair. This underlines what EREMA company group will be showing plastics industry insiders and all other visitors to the trade fair: That it is possible to implement a circular economy if everyone in the value chain works together," said Manfred Hackl, CEO EREMA Group GmbH, in his opening presentation.

In Düsseldorf, the subsidiaries of the **EREMA Group** – which are EREMA, PURE LOOP, UMAC, 3S, KEY-CYCLE and PLASMAL – will present their technological innovations, services and support together at a Group trade fair stand for the first time. Seven new recycling systems and components will be presented that enable large-scale plants with a production capacity of up to 6 t/h while setting a milestone in recyclate quality and process stability. This is made possible by technological innovations in the plasticizing unit that have been specially developed for high throughputs with low specific energy consumption, the new EREMA 406 laser filter with a 50 percent larger screening area, and new digital assistance systems that will be launched at K 2022 and made available on the BluPort® customer plat-



form. These include, for example, the PredictOn app, which helps to anticipate and eliminate imminent malfunctions based on continuous measurement and evaluation of machine data.

"CHEMAREMA is a new series we have developed for mechanical material processing as part of the chemical recycling process," says Hackl by way of introducing another EREMA innovation. Mechanical processes are often at the beginning of the process chain for chemical recycling to prepare input streams and ensure a reliable, continuous and energy-efficient flow of feed material. CHEMAREMA features extrusion technology that can be adapted to the application requirements and is designed precisely for downstream chemical processes.

For customers looking for rapidly available recycling systems for simple applications, EREMA Group subsidiary UMAC has an innovation in store for K 2022. The company, which has so far specialised in refurbishing and trading in previously owned equipment, is expanding its business area and in Düsseldorf will launch READY-

*Lucrèce Foufopoulos, EVP Polyolefins, Circular Economy and Innovation & Technology, Manfred Hackl, CEO EREMA Group GmbH (Photocredit: EREMA Group GmbH)*

MAC, a standardised, prefabricated recycling solution that can be produced from stock, based on proven EREMA TVE technology.

Finally, in the inhouse recycling segment, PURE LOOP and PLASMAL will round off the wide range of machines offered by the group of companies with their product portfolio.

In the outdoor area of the K show, EREMA will bring plastics recycling to life with live demonstrations in conjunction with cooperation partners. Different waste streams are processed for this purpose. The wide variety of high-quality applications for recyclate will be showcased in the "products made of recyclate" exhibition, ranging from technical components to consumer goods and food packaging.

At the EREMA Group, anticipation is already at a high level in the run up to K 2022. "The circular economy has



become a mega-topic in the plastics industry, even for plastic waste, although this was unthinkable just a few years ago. This boost confirms the work we have done over the past few years. There is still a lot to do, but all the players in the value chain are now pulling in the same direction. That is something that will be seen and felt at this year's K show," says Manfred Hackl.

**Borealis** – accelerating the transition towards a more circular future: Borealis is dedicated to sustainable business growth through innovation that drives the circular transformation of our industry. The K Fair 2022 theme 'Innovate Collaborate Accelerate' highlights the need to work ever more closely with partners around the globe to produce differentiated polyolefins-based solutions that make circular, modern life possible for society as a whole. Achieving the huge transformation

from today's linear system to the circular one of tomorrow will require innovation, collaboration, and acceleration throughout the entire value chain.

Borealis is committed to using their expertise and global reach to advance the circular economy of plastics. At the joint Pre-K 2022 kick-off on June 13, Borealis provided a preview of their integrated way of circular thinking and featured topics and activities at the K Fair 2022 in October. The preview covered new technologies and innovations including new packaging and infrastructure applications of the Bornevables™ portfolio of circular polyolefin products, manufactured with renewable feedstocks. New applications for Design for Recyclability, Re-Use, chemical recycling and advanced mechanical recycling were also on display.

"The transformation to a regenerative and circular system is an eradicating societal challenge," states

Lucrèce Foufopoulos, Executive Vice President Polyolefins, Innovation and Technology, Borealis. "We envision a future of plastics circularity and carbon neutrality, which can only be achieved by decisive and coordinated action across the value chain. We must act now for a better tomorrow. We welcome the occasion of the K Fair 2022 to demonstrate our commitment to 'Innovate Collaborate Accelerate' and drive the transformation of our industry."

➔ **EREMA Group**  
[www.erema.com](http://www.erema.com)

K 2022: Hall 09, Stand 9C09 and outdoor area, Stand FG-CE03

**Borealis**  
[www.borealisgroup.com](http://www.borealisgroup.com)  
[www.borealiseverminds.com](http://www.borealiseverminds.com)

K 2022: Hall 6, Stand A43

Your Profile    Our Business    50 Years

Hall 10 Booth C51

50<sup>th</sup> ANNIVERSARY 1972 - 2022

**KÜNDIG CONTROL SYSTEMS**  
The Gauge Manufacturer for Film Extrusion SWISS MADE

# Innovative Series With More Than 12 New Machine Sizes

**B**ekum's trade fair presentation will focus on the market launch of the new machine series for packaging and industrial containers. Many technical innovations and the presentation of the new Digital Service await visitors to the stand.

## PACKAGING LINE of the 8-series

At the last K-fair, Bekum presented the trend-setting machine Concept 808. With the newly developed machines of the 8-series, Bekum sets the benchmark for future extrusion blow moulding machines.

The new 8-series features include the multiple award-winning machine design, energy-efficient HiPEX 36D extruders, spiral mandrel die heads for uniform melt homogeneity, Bekum's modern Industry 4.0-capable BC 8.0 machine control system and our patented C-frame for outstanding clamping force distribution. Depending on the size, the EBLow machines of the 8-series are available as single- and double-station versions.

## New blow moulding machines

The sizes EBLow 208D, 308D and 408D form an independent, modular construction kit as components of the 8-series platform. The robust design has been optimized for a small footprint and is characterized by extraordinary flexibility and maximum efficiency. Reduced moving masses allow short dry cycle times. Mould changes, maintenance and service are simplified by easy accessibility to the extrusion head and the blow mould. The new small blow moulding machines, in the 8-series are designed for small packages and have clamping forces of 60 to 120 kN.

The modular, flexibly configurable extrusion blow moulding machines of the 8-series include the machine sizes 508, 608, 708, 808, 1008 and 1208, all of which are available as double-station machines. The 508, 608, 708 and



38 sizes are also offered in single-station versions. The series offers clamping forces from 200 to 500 kN and has been designed for maximum productivity and ease of use. With the e-Twin toggle, Bekum presents a new, unique clamping drive system for short clamping force build-up times, which, in conjunction with the patented C-frame, guarantees platen parallelism. Thus, covering the most diverse production and material requirements for packaging and handled canisters up to 20 L in the most efficient way.

## INDUSTRIAL LINE

The new industrial plant from Bekum, which is part of the new Industrial Line, represents a novelty: Instead of brittle industrial charm, one sees a uniquely designed plant whose language of form and colour impressively transfers the award-winning design of the 8 Series platform to the Industrial Line. The concept of the new Industrial Line is universally scalable, modular and includes the machine sizes BA 50, 100, 200 and 300 with clamping forces from 500 to 3,000 kN.

The heart of this series is the new clamping unit (patent pending) with two diagonal tie bars. The clamping force can be individually set on the display of the new Bekum Control 8.0, as can the size of the variable mould thickness. The mould itself can be quickly and easily removed from the side via quick-change plates. The industrial blow moulding machines of the BA series from Bekum are supplied with a speed-controlled hydraulic unit, which significantly reduces energy consump-

tion and lowers the sound pressure level on the machine to 71 dB(A).

## Digital service and support

The use of the modern BC 8.0 control system, expanded sensor technology and a secure internet connection opens up new possibilities for measuring, analyzing and optimization of the machine and its' production parameters. Freely configurable dashboards help determine the most important KPIs in order to set up individual process monitoring, to identify fluctuations such as raw materials or process parameters which can be recognized and corrected immediately. Augmented Reality (AR) solutions round off the new service offering for efficient problem solving and preventive maintenance while increasing customer benefits.

## Circular Economy – Biopolymers and Regenerate Processing

At every K-fair, for the past 15 years, Bekum introduced the Tri-extrusion technology using post-consumer recycled plastics (PCR) and chalk materials as a sustainable production solution. Combining this technology with the Bekum 3-layer heads, a proven solution exists for the cost-effective recycling of unmixed PE or PP plastic waste. By embedding PCR and/or chalk materials in the middle layer between thin layers of virgin plastic, this ecologically effective solution can also reduce the cost of container production.

This year, Bekum's exhibition machine is processing an HDPE from SABIC, which is made from 50% recycled plastics. In the new 8-series machine design, Bekum is producing consumer packaging that can be used for detergents, cleaning agents, shampoos and cosmetics.

➔ Bekum Maschinenfabriken GmbH  
www.bekum.com

K 2022: Hall 14, Stand C03



# Highlights and Innovations at K 2022

At the upcoming K trade fair, Promix Solutions will be presenting solutions for mixing, foaming and cooling of polymer melts, saving raw material costs, reducing the carbon footprint and increasing production capacity. For manufacturers of light foams, such as XPS, XPP, XPE, XPET, Promix will show how P1 cooling mix technology can be used to achieve better mechanical properties and lower foam densities. Promix displays clever solutions for efficient cooling or tempering of viscous media and for inline viscosity measurement.

Promix Microcell Technology creates a microcellular foam structure in the polymer by adding environmentally friendly atmospheric gases (N<sub>2</sub> and CO<sub>2</sub>). This reduces the product weight by 20 to 50 %, which leads to massive savings in raw materials. The saved plastic also results in fewer CO<sub>2</sub> emissions.

For the mechanical properties of physically foamed components, a foam structure that is as fine-cell as possible is a decisive advantage. Especially in the case of films and sheets for the packaging industry, a homogeneous, extremely fine-cell foam structure is essential, since the gas bubbles introduced are deformed again in the subsequent ther-

moforming process. If the cells are too large, the mechanical strength of the component is weakened and, in the worst case, defects occur.

During the Covid-pandemic, Promix conducted intensive research into the further development of physical foam extrusion and carried out various tests in its in-house technical center. With the new Promix Microcell Technology, an important milestone was reached with regard to cell size. It was possible to halve the previous cell size of 100 micron on average. The extremely fine-cell structure leads to very good mechanical values, which are comparable to those of non-foamed trays of the same thickness. Top Load tests have confirmed: With Promix Microcell Technology, weight savings of around 20% can be achieved without sacrificing mechanical properties.

In addition to its use in packaging films, Promix Microcell Technology is also suitable for sheets, foam core and corrugated pipes as well as profiles, cable sheathing, blow molding and blown films. Promix will exhibit relevant key components at the K and will provide information on possibilities



*Assembly of Microcell Technology components at Promix Solutions*

within specific fields of application. In the meantime, more than 250 industrial references are in operation and various machine manufacturers are successfully integrating the technology into their plants.

Promix Microcell Technology can be used for almost all raw materials. For example, for PP, PE, PET, TPE, TPU, PA, hard & soft PVC and bioplastics. The technology is available both for newly planned extrusion lines and as a retrofit solution.

➔ Promix Solutions AG  
www.promix-solutions.com

K 2022: Hall 9, Stand E18

## Herbold Meckesheim GmbH - Your partner for plastics recycling

### Modular system solutions for a functioning circular economy

See our innovative full-sized machinery at our Booth B34 in Hall 9 at K 2022 which are part of our modular system solutions for customized automated plastic recycling plants.



➔ Hot Washing

We have a long lasting expertise in size reduction, washing, separating, drying and agglomeration - to recycle new, used or contaminated plastics.

➔ Visit us in Düsseldorf at K 2022 in Hall 9, Booth B34



➔ Recycling Lines



www.herbold.com

# Modular Automation Concept

Increasingly shorter product life cycles, a shortage of skilled workers and the trend towards individualization require flexible automation solutions tailored to customer requirements. The answer to this is the new Kiefel Speed Automation (KSA) from Kiefel, which is based on a modular system. In addition to customer-specific automation solutions, with the KSA the company offers completely modular and therefore flexible standard automation for the KMD series, especially for the SPEEDFORMER KMD 78.2 Speed. The company is presenting the solutions this year at K 2022.

The KSA is optimally matched to the KMD series and can be integrated into existing systems as well as into new machines. This allows the production of packaging with various modules to be automated and modernized. A KSA module forms stacks from partial stacks, e.g. of food trays. Another module is the carton erecting and closing unit. It removes cartons from a box magazine, erects them, and, if necessary, inserts a protective bag for hygienic packaging of the products. The stacked packaging is automatically inserted into these. As soon as the carton is full, the bag and carton can also be automatically closed and transported onwards as required. The KSA range also includes an automatic labeling unit.

The palletizing unit consists of two palletizing stations. This makes it possible to palletize in one station while the other is being emptied. If the products are not to be packed in cartons, the sleeving module can be used. Here, one or more stacks are packed and shrink-wrapped.

## Easy integration of the KSA in the KMD series

This means that intelligent, modular automation solutions are available for the most common applications, which contain fewer product-specific format parts and can still be optimally adapted to customer requirements. This offers high product design flexibility. The tool layout has little or no impact on automation and the footprint of the KSA is minimal. The smooth integration of the KSA modules into the KMD machines means that the additional costs that usually arise with retrofitting are avoided. The standard KSA solution from Kiefel is designed for the fast cycle times of the KMD machines. Another bonus: The KSA makes it possible for just one person to operate the machine.

*Settings, adjustments and test runs are carried out intuitively via the new HMI*

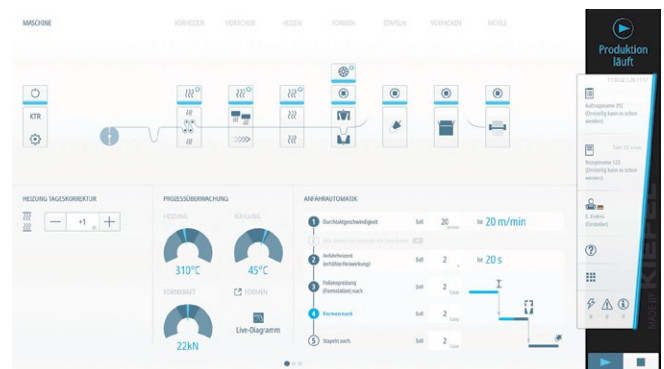

*The KMD 78.2 steel rule machine will be demonstrated live at the K trade fair (All pictures © KIEFEL GmbH)*

Some of the automation modules can also be integrated into the SPEEDFORMER KTR series tilting machines.

## Sustainable packaging with the KMD 78.2 Speed

At the K 2022 Kiefel's packaging specialists will be demonstrating a SPEEDFORMER KMD 78.2 Speed producing a tray made from an rPET film with a thickness of 0.35 mm – light, stable and sustainable. The steel rule machine is just as at home in large series production as it is with smaller quantities. The machine's highlights include high productivity and process control, as well as intuitive user guidance.

The interaction of servo motor drives, the optimized symmetrical toggle lever system and particularly robust cast steel tables ensure high efficiency along the entire service life. The KISS-CUT system guarantees maximum machine uptime and precision with its high punching quality and reliability.

The separately driven plug assist provide material savings, high levels of process control and outstanding product quality. During machine development, the focus was on energy efficiency, for example of the heating elements or the drives, which all have an energy recovery system.

The new KMD generation not only saves energy, but film too. The film feed table with rollers prevents scratches and und particle contamination and ensures reliable and safe film transport. The forming surface of the machines makes

*KSA modules, such as the bag inserter or carton sealer shown here, can be connected to existing and new KMD machines*



optimum use of the film width. The servo motor-driven components, the high forming air speed and the cutting force ensure speed and accuracy. Ergonomic tool changing systems make tool changes quick and easy.

**Machine operation made easy**

Operation of the machines can be grasped quickly – thanks to the machine visualization, the human-machine interface (HMI). The production process is clearly visualized on a dashboard on a screen attached to the machine – machine operators can thus monitor the machine status and form-

ing process at a glance. Settings, adjustments and test runs are carried out intuitively via the HMI. Supported by clear diagrams and animations as well as step-by-step instructions, machine training time and adjustment processes are reduced to a minimum. Kiefel received the Red Dot Award in the Brands & Communication Design category in 2020 for this.

► KIEFEL GmbH  
www.kiefel.com

K 2022: Hall 3, Stand E90

# New Brand Advances the Circular Economy by Enabling Use of More Recycled Materials in End-Use Applications

SI Group, a leading global developer and manufacturer of performance additives, process solutions, pharmaceuticals, and chemical intermediates, will be introducing its new additives brand for plastics recycling at the K 2022 exhibition.

The company’s newest brand will encompass a comprehensive platform of innovative additive solutions designed to accelerate the transition to a more circular economy and lead to a more sustainable plastics industry. The first solutions to be introduced under the new brand name will be stabilizers for recycled polyolefins and PET that are specifically designed to allow customers to use more recycled materials without compromising performance in the end application. “We’re thrilled to deliver solutions that enable our customers and the industry to move towards a truly circular economy. Our new solutions upgrade the performance of recycled plastics so they can be used in more demanding applications again and again,” said Irfaan Foster, Market Development Director at SI Group.

In addition to revealing the new brand, SI Group will be presenting its expanded portfolio and latest sustainability developments at K 2022. Key product updates to be showcased include a new masterbatch grade of WESTON™ 705 liquid antioxidant and ULTRANOX™ LC stabilizers. Since the last K show in 2019, the company has increased its focus on sustainability. “While sustainability has been critical to our success for a long time, we recently modified our corporate mission statement to include sustainability, as we recognize its key role in our journey to becoming the global additives powerhouse,” said Joey Gullion, Chief Commercial Officer at SI Group. “Our presence and activities at K 2022 will reflect our commitment to a more circular plastics industry.”

► SI Group  
www.siigroup.com

K 2022: Hall 6, B08



ERGE Elektrowärmetechnik - Franz Messer GmbH  
91220 Schnaittach - Hersbrucker Straße 29-31  
Tel. +49/9153/921-0 Fax +49/9153/921-117  
www.erge-elektrowaermetechnik.de  
mail: verkauf@erge-elektrowaermetechnik.de

HEIZEN  
HEATING



TROCKNEN  
DRYING

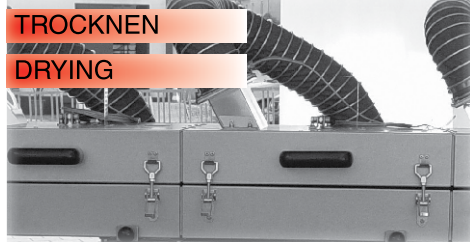

REGELN  
CONTROLLING



ELEKTROWÄRME TECHNIK FRANZ MESSER GMBH

19. - 26. 10. 2022  
Düsseldorf, Germany  
Stand: 11E59





# „Inspire Beyond Measurement“

In the forefront of the K show 2022, iNOEX announces the new corporate design as well as the corresponding claim "INSPIRE BEYOND MEASUREMENT". The revised corporate identity combines tradition with international aspirations and focuses clearly on a modern, emotional visual language and tonality.

For more than 35 years, the company has been using its innovative strength and know-how to realise ideas with a future. Efficiency, precision and the willingness to push boundaries make the products and services even better. As an integrated solution provider, iNOEX delivers intelligent and innovative solutions and services that create added value for customers. The products stand for high quality, reliability and user-friendliness.

At the K show in Düsseldorf, iNOEX will be presenting the latest product developments in the field of high-precision measuring and control technology as well as product premieres in radar technology. Innovative solutions for more efficient extrusion processes – whether for pipe, hose, cable, film or profiles – as well as exciting novelties and versatile application possibilities await the visitors.

**WARP CP:** Measuring system with 8 radar-based wall thickness sensors for recording the various structures of a corrugated pipe. The outer and inner diameters as well as the wall thicknesses of the bell, the crest, the liner and the valley can be resolved. The system is available for large corrugated pipes with diameters from 300 mm.

The 8 sensors around the corrugated pipe scan it continuously. Since the corrugated tube has different structures, it is therefore necessary to assign the measurement data to the corresponding position on or in the pipe. The WARP-CP algorithms do this automatically and prepare the data for the user in such a way that he is provided with different graphics and corresponding measurement data for each structure.

**WARP 100:** Inline pipe measuring system for wall thickness and diameter



iXRAY

measurement at up to 38 measuring points and 19 axes. More than 1100 measurements per second guarantee a complete measurement. The WARP 100 is available in three sizes and can be used for measurements in the diameter range from 60 to 630 mm.

The specially developed optics allow the alignment of the radar wave to be focused on the centre of the pipe. The sensors are arranged in such a way that the measuring spots overlap, thus ensuring close-meshed coverage in the extrusion direction. The maximum line speed for 100 % coverage is up to 11.8 m/min. Measured variables such as wall thickness, diameter, ovality, eccentricity and process conditions (e.g. sagging) are precisely recorded, documented and used for automatic process control.

**WARP portable:** Mobile, radar-based hand-held measuring device for punctual wall thickness measurement, specially designed for medium and large pipe extrusion as well as for sheets. Wall thicknesses from 2 to 110 mm (depending on the material) can be measured. Whether as a quick cen-

tring aid in the start-up process, for final inspection of production or as a stock control device, the possible applications are very flexible.

Not only can wall thicknesses at pipe ends be measured, but also the course inside a pipe section or a sheet. The measurement is carried out at the push of a button and the last 100 measured values including the measuring angle on the pipe as well as the time stamp are stored.

These highlights of radar technology as well as the further developments in plastics measurement with radar sensors provide customers with decisive competitive advantages. Furthermore, tried and tested products are also presented at the latest technological level.

**iXRAY:** Measurement of wall thickness distribution, inner and outer diameter, ovality and eccentricity for single and multi-layer pipes and hoses. Thanks to a precise spatial resolution and repeatabilities in the  $\mu\text{m}$  range, the system reliably achieves exact measurement data. At high line speeds, the X-ray system - optionally two or three axes - delivers precise measurement results.

The standard systems are available for tube dimensions from 1 to 63 mm. The iXRAY series is user-friendly and the line operator only has to select the tube, hose or cable recipe to start the



SAVEOMAT



WARP

measurement. Furthermore, the X-ray units do not pose any risk to the operator. The radiation output is far below the permitted legal limits and other safety aspects ensure safe use.

**AUREX ERS:** The AUREX ERS uses the measuring technique of the Electronic Rotating Scanner (ERS) principle. With this active-passive measurement, every point of the measured object is detected 100 % in longitudinal and circumferential direction, so that even minimal tolerance deviations are detected.

Coextruded layers can also be detected as soon as they can be physically resolved with ultrasound. In addition to the AUREX ERS, the "Quality Check", a wall thickness error check, is optionally available. The "Quality Check" detects anomalies on the surface, in the material and on the inner surface of the pipe.

**SAVEOMAT:** Gravimetric weighing is the basis for the automation of extrusion lines. Continuous and highly precise gravimetric weighing and level monitoring of solid and liquid materials, enable material savings through exact mass throughput and metre weight control.

The funnel weighers are suitable for a wide range of materials and, in addition to the high level of precision, also offer maximum flexibility through easy cleaning and a quick product change.

They are controlled by means of an intuitive user interface.

At the K show, iNOEX will be exhibiting the following individual funnel weighers:

- **SAVEOMAT G:** Basic version of the SAVEOMAT series. These mono hopper scales are suitable for granules.
- **SAVEOMAT P:** Funnel weigher specialised in the blockage-free feeding of powder with a maximum chalk content of up to 20 %.
- **SAVEOMAT HF:** Dosing unit for materials with a chalk content of up to 100 %. Depending on the material and requirement, with a twin-screw or spiral dosing unit.
- **SAVEOMAT Liquid:** Multicomponent dosing station for recipe-accurate dosing of solid and liquid components (use of silane and peroxide).

**iDM 4.0:** Central data storage for the collection of all process and quality data of the iNOEX systems in the extrusion line. Optimisation potentials can be identified and product-specific key figures analysed and evaluated. The software is installed as a virtual machine in the customer's network, so no additional hardware is required. OPC-UA as a standardised process data interface transfers the data. Integration of almost all types of interfaces is possible via the iDM Gateway.

By using the Grafana software, iDM 4.0 enables graphs, visualisations and data evaluations, data export as .csv or .xls, live data on the database server, use as a hall monitor as well as ready-made and freely configurable dashboards and reports for each connected system. Site-wide statistics such as overall line effectiveness and process capability and a notification function are also possible.

INOEX GmbH  
www.inoex.de

K 2022: Hall 10, Stand C46

**BRÜCKNER**  
MASCHINENBAU **B**

## STRETCHING THE LIMITS

Higher plant efficiency for  
sustainable film production



19.– 26. Oct, Düsseldorf, Germany

www.brueckner.com

# Innovative Degassing and Decontamination Technologies for Demanding Recycling Applications

## Extrusion Technology

Gneuss' MRS Extrusion Technology has proven itself as an alternative for the reprocessing of contaminated materials like polyester, polystyrene, polypropylene or polyethylenes. In combination with the highly efficient Gneuss Rotary Filtration Systems and optimized vacuum technology, customizable recycling lines tailor-made for a specific material can be engineered. Several Letters of Non Objection (LNOs) from the FDA, EFSA conformity and local approvals in Latin America confirm the decontamination efficiency of the technology. Samples of polypropylene tubs for food applications made with 30 % post consumer PP and PS sheet made from 30 % post consumer PS, processed on Gneuss OMNI Recycling Machines with MRS extruders and RSFgenius filtration systems, will be shown at K.

**OMNI Recycling Machine for post-consumer fiber or thermoform reclaim:** Gneuss will show its latest machinery innovations for today's and tomorrow's recycling needs with a complete OMNI Recycling Machine featuring a new 3C Rotary Feeder, an *MRSjump* 70 extruder, a fully automatic melt filtration system *RSFgenius* 90 and an online viscometer *VIS*, for the processing of 200 kg/h (450 lbs/h)

*Gneuss OMNImax Recycling Machine with MRSjump Extrusion System, Rotary Filtration System and 3C Rotary Feeder*

of undried and uncrystallized polyester (PET) thermoform reclaim.

**3C Rotary Feeder:** The newly developed 3C Rotary Feeder makes it possible to use low bulk density materials without any external processing steps. A conveyor belt feeds shredded reclaim material into the hopper, where a fast-rotating disc with knives cuts, compacts and pre-conditions the material. The knives add energy into the material and start the heating and degassing process before the material is automatically fed into the *MRSjump* extruder.

***MRSjump*:** The MRS extruder is based on conventional single screw technology but is equipped with a multiple screw section for devolatilization. It enables very efficient and gentle decontamination of PET, whilst achieving the requirements for direct food contact standards. The MRS extruder permits the processing of R-PET directly into high quality end products such as packaging sheet, strapping tape or filaments without pre-drying by using a simple and rugged vacuum system. This is achieved by means of its patented processing section. The Multi Rotation Section is a drum containing multiple satellite single screws, driven by a ring gear and pinion transmission.

The satellite screws rotate in the opposite direction to the main screw.

This disproportionately increases the surface exchange of the polymer melt. A

large opening for venting, exposing the full length of the satellite screws, is completely under vacuum. This provides unrestricted access to the polymer melt, the surface of which is constantly replaced at an extremely high rate by the action of the satellite screws in the multiple screw section. The surface area – and the surface area exchange rate – available for devolatilization are far greater than in other extrusion systems. As the thermal and mechanical stress on the polymer melt is minimized, PET processed on the MRS extruder has excellent optical and mechanical properties.

The new *MRSjump* has a longer, modified version of the Multi Rotation Section, which ensures both a longer residence time of the material and more surface area exchange under vacuum. The longer Multi Rotation Section, coupled with a powerful vacuum system operating at 1 mbar, can be used to boost the viscosity of R-PET and to hold it at a stable level in spite of variations in the input material. Therefore, there is no need for any liquid phase (LSP) or solid state polymerization (SSP). With the stabilization and/or increase of the intrinsic viscosity in the extrusion process, the *MRSjump* is especially well suited to recycling e.g. PET film waste or fiber reclaim – applications for which direct recycling with one single extrusion step was previously impossible due to low intrinsic viscosity or variable input viscosities. In combination with Gneuss' Rotary Filtration Technology, a high melt purity

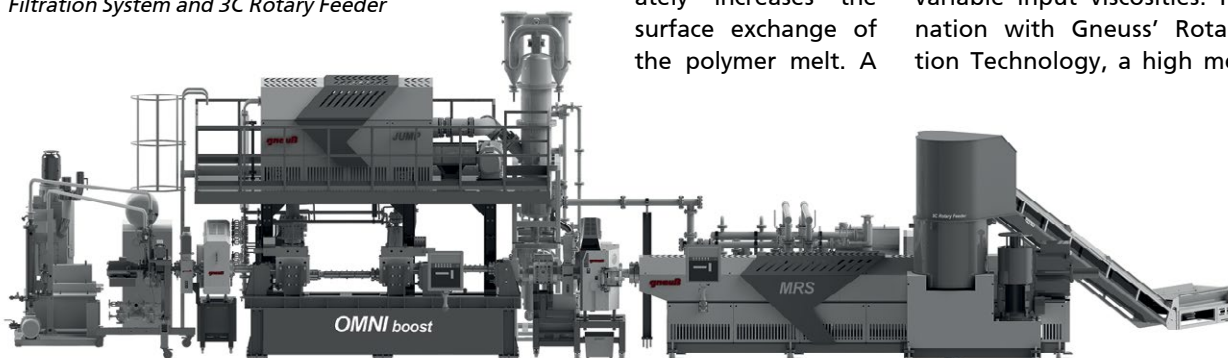



is guaranteed. Quality assurance can be provided with an online viscometer VIS for measuring melt viscosity.

As demand for PET bottle flakes outpaces supply and processors are looking for alternative feedstock (e.g. to fulfill recycled content mandates) the MRS*jump* offers an excellent solution for PET thermoform, film or fiber recycling, while the newly developed MRS cutter compactor makes it possible to use low bulk density materials.

In parallel, with Gneuss' headquarters only about 200 km from the show, a complete PET sheet extrusion line with an OMNI*max* Recycling Machine – consisting of an MRS*jump* 70, Gneuss' deep vacuum system and a fully-automatic filtration system RSFgenius 75 – and a sheet downstream with a 500 mm wide extrusion die will be running in Gneuss' technical center open to visitors.

Additionally, an OMNI*boost* Recycling Machine with a polyreactor JUMP will be operating in Gneuss' technical center for an online demonstration. The JUMP can lift the IV value of a PET melt up to 0.95 dl/g.

In the JUMP the polymer passes over several slow turning elements which create a polymer film, the surface of which is constantly renewed. The reactor vessel is kept under vacuum, through which volatile substances are reliably removed. By regulating the residence time in the reactor, the vacuum, the fill level and the speed of rotation of the agitating devices, the polycondensation reaction can be altered to achieve the required product properties. The JUMP is a robust and reliable liquid state polycondensation system (LSP) and a compact, quick and efficient alternative to conventional solid state systems (SSP). It enables direct reintroduction of the polymer into the production process without the need to remelt the PET.

**Filtration Technology**

Gneuss Filtration Technology will exhibit several different models of their patented Rotary Filtration Systems. These continuous filtration systems are characterized by a filter disk on which the screen cavities are located in a ring pattern. Screens can be



Patented Rotary Filtration System RSFgenius

changed on the part of the filter disk that is not active in the melt channel, while the production process continues to run without any interruptions or disturbances.

Gneuss' top model, the RSFgenius, operates with an integrated back-flushing system offering self-cleaning for very demanding applications and highest quality requirements. Screens can be automatically re-used up to 400 times and filtration finenesses below 10 microns/1200 mesh are available. There will be an RSFgenius 250 on display, with an active screen area of 1350 cm<sup>2</sup>/209 square inches, for throughputs of several thousand kilos per hour, depending on the type of polymer and the filtration fineness.

MACHINERY PERFORMANCE,  
SUSTAINABILITY SOLUTIONS, AND DIGITALIZATION  
AWAITS *you!*



Visit us at  
**2022 HALL 16**  
**BOOTH A43**



Learn more  
**TODAY!**

Leverage your competitive advantage with our collective expertise.



Where your ideas take shape.

Retrofitting a fully-automatic RSF-*genius* to an existing extrusion line, whether in a pelletizing, sheet, fiber or pipe application, permits the use of more contaminated (and often cheaper) material and/or the use of finer screens. Every retrofit is tailor-made and usually without the need to move any existing equipment.

There will also be an SFneos 150 and an SFX*magnus* 90 on display. These models are also continuous, pressure and process constant, but not back-flushing, therefore these systems are for applications that don't require self-cleaning. The SFneos 150 offers an active filtration area of 450 square centimeters/ 70 square inches for applications like foam sheet, battery separator or PVC. The SFX*magnus* 90, with its completely encapsulated design, offers an active filtration area of 350

square centimeters/ 54 square inches for applications like PET or BOPP sheet or other sensitive materials.

### Measurement Technology

Gneuss provides flexible sensor solutions for pressure and temperature measurements, individually tailored to your application.

Whether standard sensor or application-specific customized solution. The flexible manufacturing structure allows shortest delivery times.

In addition to standard-compliant pressure monitoring, Gneuss offers the necessary quality assurance of the measuring equipment.

The latest generation of Gneuss sensors and pressure monitors communicates completely digitally. Integrated RFID chips for digital gauge monitoring are available for all sensor models.



*Gneuss sensors with digital gauge monitoring*

➔ Gneuss Kunststofftechnik GmbH  
www.gneuss.com

K 2022: Hall 9, Stand A22

# Measuring Technology: Innovative Technologies for a Sustainable Future

The focus of SIKORA's trade show appearance at K 2022 is the world premiere of two new models of the CENTERWAVE 6000 family for the measurement of pipes by means of millimeter wave technology already early in the extrusion process. Also new will be the PURITY SCANNER ADVANCED with three optical cameras and one X-ray camera for highest performance in inspection and sorting of plastic pellets. In addition, visitors are invited to inspect and analyze their pellets live and on-site with the laboratory testing device PURITY CONCEPT V. As savings are part of the SIKORA technologies, visitors will learn how they can save material, costs and CO<sub>2</sub> in their extrusion line.

### World premiere: New CENTERWAVE 6000/1200

SIKORA offers the CENTERWAVE 6000 for online measurement of wall thickness, inner profile and diameter as well as ovality over the entire circumference of plastic pipes. With the world premiere of the CENTERWAVE 6000/1200, a new model is now avail-

able that specifically covers diameter ranges from 250 to 1,200 mm. The CENTERWAVE 6000/1200 thus meets the demands of large-diameter pipe manufacturers. "The new model can be easily integrated into the production line thanks to its slim design and is particularly suitable for extrusion lines in which pipe diameters of up to 1,000 and 1,200 mm are produced," says Christian Schlich, Head of Sales – Hose & Tube. In-line, the system supports immediate centering, seamless, reliable quality control, and optional automatic control. All models of the CENTERWAVE 6000 device series are characterized by their innovative measuring principle based on millimeter wave technology. Operation is intuitive at the push of a button. "Once activated, the operator immediately receives continuous and precise measured values – without presetting the product parameters, without the influence of a coupling medium (water) and without any calibration," Schlich explains. To ensure this, the measuring system automatically determines the exact refractive index of the material at the measuring position. "Patented

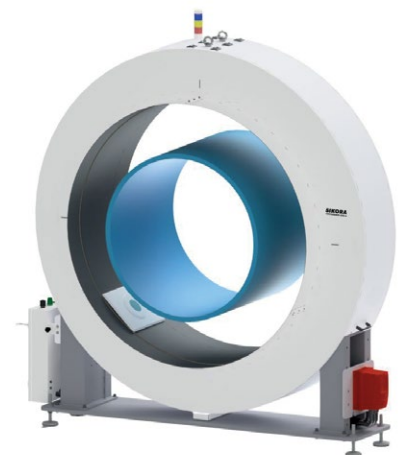

*At K, SIKORA presents for the first time the CENTERWAVE 6000 for pipe diameters from 250 to 1,200 mm*

and therefore unique is the continuous measurement of a very important characteristic value of the pipe wall: the refractive index of the material. With its help, both the wall thickness and the outer diameter can be precisely determined without having to calibrate the measuring system," Schlich says. Directly after the vacuum tank, knowledge of the refractive index, in addition to the measurement, already



Measuring values of the CENTERWAVE 6000 are clearly visualized

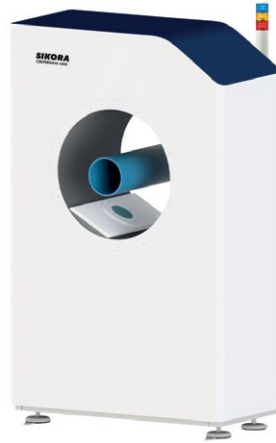

The smallest model of the CENTERWAVE family for small product diameters from 50 to 250 mm



Inspection and sorting of plastic pellets with the PURITY SCANNER ADVANCED

provides an accurate prediction of the wall thickness and diameter values to be expected after cooling at the end of the extrusion line. A manual input of the refractive index when changing the production conditions is not necessary at any time due to this procedure. "The CENTERWAVE 6000 convinces mainly due to the advantages that the technol-

ogy offers for the extrusion process," Schalich explains. The "one-button operation" rules out operating errors, target dimensions are quickly achieved, start-up scrap is avoided, highest quality is ensured, and processes are optimally controlled.

**World premiere: CENTERWAVE 6000/250**

Millimeter wave technology from SIKORA was previously known for the measurement of larger pipes. At

the K, SIKORA presents for the first time the CENTERWAVE 6000/250, for smaller tube diameters from 50 to 250 mm. It enables 100 % measurement of the wall thickness, as well as the determination of diameter and ovality for tubes with wall thicknesses from 1.5 mm due to its automatic adjustment of the rotation speed. Like all CENTERWAVE devices, the system is equipped with a transceiver that continuously rotates 360 degrees around the product. In doing so, the

# WE DRIVE THE CIRCULAR ECONOMY.



**EREMA**  
PLASTIC RECYCLING SYSTEMS

Whether it is inhouse, post-consumer, bottle or chemical recycling: closing the loop in a precise and profitable way if machines are perfectly tuned for the respective application. Choose the number one technology from EREMA when doing so: over 6500 of our machines and systems produce around 14.5 million tonnes of high-quality pellets like this every year – in a highly efficient and energy-saving way.

**K22 MAIN BOOTH:** Hall 9 / Booth C09  
**OUTDOOR AREA:** FG-CE03

erema-group.com

**K22** Another life for plastic. Because we care.

CHOOSE THE NUMBER ONE.



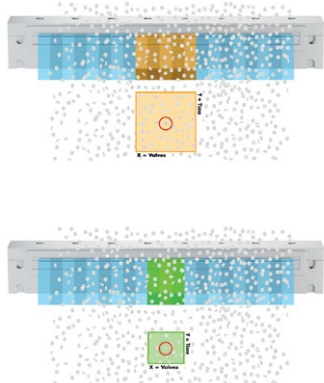

*The "Hybrid blow-out" feature allows the customer to select which impurities in the material are not critical and to choose a smaller blow-out unit for these, so that their by-catch is reduced.*

CENTERWAVE 6000/250 automatically adjusts the transceiver's rotation speed to the line speed, thus ensuring 100 % seamless quality control.

#### **Novelty: PURITY SCANNER ADVANCED with three innovative 25 µm high-resolution black and white cameras**

The plastics market is changing. Raw material shortages and price increases are challenging the industry. Consequently, the demands of the manufacturers regarding quality control of pellets are also increasing. SIKORA takes this change into account and offers with the PURITY SCANNER ADVANCED a modular system for flexible optical online inspection and sorting of plastic material. "Even the smallest, critical contamination are reliably detected and sorted out by the system. Both the detection and the ejection behavior of contaminated pellets are perfectly coordinated," explains Ralf Kulenkampff, Head of Sales – Plastics. Thanks to the modular concept, different camera types can be used depending on the inspected material. In addition to optical 25 µm high-resolution cameras, which detect black specks and discol-

*The combination of three optical high-resolution black and white cameras ensures the highest detection of contamination from 25 µm in plastic pellets*

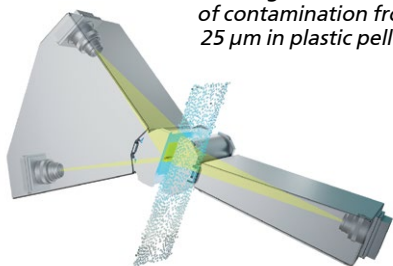

orations, an X-ray camera can be installed to detect metallic contamination. Common systems on the market have a maximum of two optical cameras. However, these quickly reach their limits due to relatively low coverage as soon as the contamination are outside the cameras' field of view. "By using a third black and white camera in the PURITY SCANNER ADVANCED, a significantly higher detection rate is achieved, so that more contaminants are detected – this is unique with our system," explains Kulenkampff.

The PURITY SCANNER ADVANCED automatically sorts out detected contamination via a blow-out unit. For optimizing the by-catch, SIKORA has developed the "hybrid blow-out" function. The customer can define in advance which contaminants in the material are uncritical and select a smaller blow-out unit for these, so that their by-catch is reduced. These include, for example, small, light-colored black specks that frequently occur in the material. On the other hand, a larger blow-out unit is specified for critical contaminants, for example metal contaminants, which can impair the functionality of the subsequent end product. "The interaction of reliable detection and hybrid blow-out ensures the highest material quality. At the same time, production processes are optimized, and the reduced by-catch contributes to cost-efficient and sustainable production," says Kulenkampff.

#### **Live material tests with the PURITY CONCEPT**

For random sample inspection of plastic pellets or test plates for speck analysis, SIKORA presents at the K the PURITY CONCEPT Systems with optical inspection (PURITY CONCEPT V) or X-ray analysis (PURITY CONCEPT X). Within a few seconds, depending on the system, the test material is inspected for metal contamination or optical deviations. Contaminants are automatically detected, visualized and statistically evaluated. In a laboratory environment live material tests with the PURITY CONCEPT V are offered at the SIKORA booth. Visitors are invited to send in free of charge pellet samples, which will be inspected and analyzed directly on the booth with the PURITY CONCEPT V. Alternatively, visitors can



*Live material tests at K: Customers are invited to bring small quantities of plastic material to be inspected by the PURITY CONCEPT V at the SIKORA booth*

bring small quantities of their pellets directly to the booth for testing and evaluation and personally convince themselves of the precision, speed and ease of operation of the system.

#### **Service**

Maintaining the availability and efficiency of the SIKORA systems at the customer's site is SIKORA's top priority. At the K, the SIKORA service team presents the entire range of its service portfolio. From installation and commissioning of the devices to consulting and training, always matching the individual customer requirements.

#### **Testing savings potential**

In extrusion, costs can be specifically absorbed by using sustainable measuring technology. For example, optimal centering in pipe production by the CENTERWAVE 6000 measuring system leads to a material savings potential of approx. 3 to 5 %. Start-up scrap is reduced to a minimum and, in addition to material, valuable production time is saved which can be used for processing additional production orders. In addition, this saves energy during production and at the same time contributes to more sustainability by conserving valuable resources. SIKORA has developed its own tool to calculate possible saving potential in terms of material, production time, costs and CO<sub>2</sub> emissions which will be presented for the first time to a broad audience at the K.

→ SIKORA AG  
www.sikora.net

K 2022: Hall 10, Stand F14

# Shredding Solutions for Post-Consumer Plastic Recycling

At this year's K trade show, WEIMA will be exhibiting two new plastic shredders with single-shaft technology: the revised W5.18 universal machine and the WLK 1000 with innovative FineCut rotor for secondary shredding. In addition, there is another machine premiere in the field of compaction. With the new PUEHLER C.200 press, fine particles can be dewatered and compacted in a single step after the washing process.

The global demand for recycling technology for plastic post-consumer and production waste continues to grow in these turbulent times. This primarily includes machines for one of the first process steps – shredding.

If you are looking for a particularly powerful, maintenance-friendly and versatile plastic shredder, you need to look no further than the W5.18 (a further development of the successful WKS series) with an output of up to 280 kW. With its 1,800 mm long and 500 mm diameter rotor, the all-rounder for plastics of all kinds effortlessly shreds both hard plastics and tear-resistant fibers and films. The proven swing ram for aggressive, controlled material feed also helps here. The generously dimensioned inspection flap provides direct access to the rotor during service work.

For particularly demanding applications, i.e., for heavily contaminated material (e.g., sand, soil or metallic residues), WEIMA offers special options for wear and corrosion protection. These include a Vautid shell or hard facing using weld seams for the rotors, additional wear plates in the cutting chamber or wear-resistant screens made of Creusabro or Hardox. Cutting blades are available in 60 mm and 80 mm edge lengths. All of this significantly extends the service life of the components.

Machines in the W5 series can be equipped with three different drive concepts. The hydraulic drive as well as the high-torque drive are particularly powerful, energy-efficient and robust against foreign objects. The electromechanical drive with the in-house developed WEIMA WAP gearbox will win customers over with its low investment and maintenance costs. Of course, all W5 machines have the connectivity features commonly found on the market for networked production.

WEIMA produces over 1,000 solutions annually for shredding and compacting all types of residuals. The WLK 1000 shredder on display at the K trade show offers numerous advantages: a compact footprint, a screen basket that can

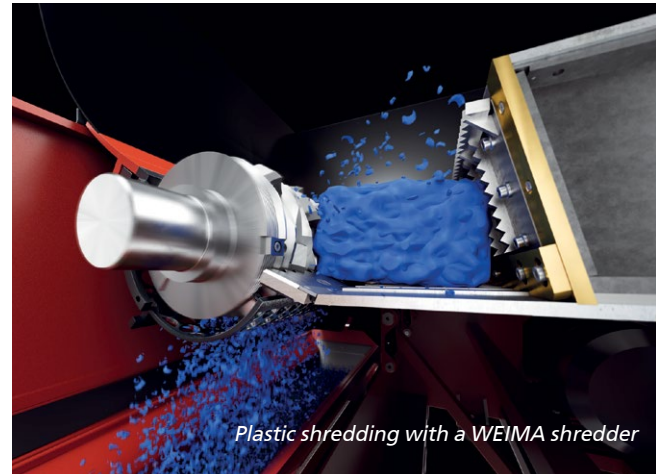

Plastic shredding with a WEIMA shredder

be hydraulically lowered, various cutting geometries and equipment options and easy integration into production lines. The exhibited machine has an electromechanical drive with power belt and gearbox. The highlight is located in the cutting chamber. A 1,000 mm long FineCut rotor is installed there, which makes the shredder ideal for secondary shredding (up to 10 mm). The rotor works according to the shear cut principle, which combines in a robust form the properties of a classic shredder with those of a cutting mill.

Many recyclers are familiar with the problem: the expensive disposal of fine fractions (fine rejects) after washing shredded post-consumer plastics. An important cost driver is wastewater that still adheres to the plastic. With the new PUEHLER C.200 dewatering press, WEIMA is presenting an economical compact machine that provides a remedy with solid, low maintenance technology. A hydraulic pusher cylinder compacts loose, wet plastic flakes into handy, almost dry compressed discs with a diameter of 200 mm. The pressed-out liquid is discharged separately via a drip tray. PUEHLER presses can be operated both as a stand-alone solution as well as integrated in a production line. The lower weight of the compressed discs contributes significantly to reducing disposal costs.

WEIMA Maschinenbau GmbH

[www.weima.com](http://www.weima.com)

K 2022: Hall 9, Stand A39



DISCOVER OUR WIDEST RANGE OF INNOVATION  
OUR NEW 8-SERIES WITH  
**20 NEW MODELS**

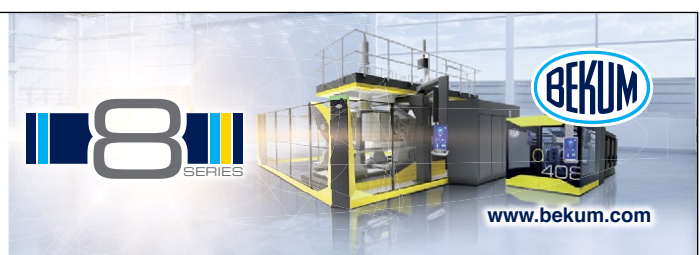

# Intelligent & Smart Product Solutions for Inspection, Analysis and Classification of Gels & Contaminations

2022 invites to the halls of Messe Düsseldorf after a long break from the trade fair. Enough time to develop intelligent & smart product solutions at OCS.

## Real-time inspection using intelligent inspection technology

The OCS inspection systems, starting with the PS25C Pellet Scanner (laboratory or online application) for the inspection, measurement evaluation & classification of e.g. granulates, recyclates and powders up to the Wide Web Inspection System for film plants, can detect irregularities in real time. This is made possible by special camera and lighting technology and the use of high-performance hardware and software components. Whether gels, black specks or burn marks, the OCS systems detect and classify defects of any type. Particularly practical in the online application: the data transmission of the real-time results to the production and process control.

## Biopolymers and recyclates - quality control is essential

Due to supply chain bottlenecks, alternative raw materials must increasingly be procured or researched. A sustainable solution is therefore the

*Using OCS laboratory extrusion lines, the polymer film will be inspected & analysed*



*The OCS analysis software detects quality variations in real-time during the production process*

use of biopolymers and recycled materials. Trust is good, quality control is better. It is therefore even more important to find concrete solutions for this. OCS has taken on this issue and developed standard testing procedures to ensure that high and consistent quality continues to be delivered. The OCS test systems can be used for incoming goods inspection or in the laboratory for further analysis.

## Web Inspection System FSP600 with new MCE Technology

With the smart and unique MCE (Multi Channel Evaluation) technology, detection can be combined in reflected or transmitted light mode as well as in dark and bright field applications, using only one hardware (camera). This enables the simultaneous detection of defects on up to 6 channels. For example, one channel for the reflection of surface defects, three additional channels for transmission (RGB) for better defect detection and classification. Defect references are taught in with the assistance of the teach-in function, and a common classification of the film rolls can be carried out. Furthermore, the OCS software can be integrated into systems such as Ruby ("artificial intelli-



*Make gels & contaminations visible in the polymer film*

gence" from Windmüller & Hölscher), for example, and thus creates further added value for the operator.

## OCS Software 4.0 – the intelligent solution for saving time and reducing costs

The machine operator is informed about process deviations in good time and can counteract quality variations. Both in the raw material manufacturing industry and in the plastics processing industry, seamless traceability is a must and helps in gaining knowledge.

For example, in the case of film manufacturers: here, film rolls can be locked by the system without the operator having to interact. This is made possible by OCS analysis software, which uses the material, raw material and process parameters from the PDA system in relation to the respective quality/film grade, thus providing long-term statistical process control. This not only reduces reject quantities to a significant degree, but also means saving a lot of time and reducing costs.

➔ OCS Optical Control Systems GmbH  
[www.ocsgmbh.com](http://www.ocsgmbh.com)

K 2022: Hall 10, Stand A34





# TAIWAN

SMART MANUFACTURING

Visit us at Hall

1, 3-5, 7, 9, 10, 12-17

Scan to  
Find  
Us!



Organized by



Bureau of Foreign Trade, MOEA

Implemented by



Taiwan External Trade Development Council



Precision Machinery Research & Development Center



Taiwan Association of Machinery Industry

# Two Innovations for the Circular Economy Live at the Booth

The color of an end product is now an important aspect of modern branding. With ColorAdjust from KraussMaffei, color variations with input goods of different colors are a thing of the past. The innovative system combines a color measuring device with photo-spectrometer technology and machine control to ensure precise, reproducible colors. Visitors can observe the fully automatic color correction process at the K trade show. In the CircularEconomy process on the booth, a twin-screw extruder compounds shredded medical caps into a fiber-reinforced, color-precise recyclate.

The ColorAdjust solution developed by KraussMaffei is the first of its kind on the market. It is designed not only for contactless monitoring of color variations, but to compensate even for minor deviations by directly adjusting the precise color setpoint. This gives compound processors high reproducibility even when processing input materials of varying color spectrum. The color setpoint is rapidly achieved when starting the compounding process after a stop as well as in the event of color changes. In view of the fact that start-up scraps and reject material to be subsequently disposed of are thus minimized, ColorAdjust ensures sustainable and highly efficient produc-

*KraussMaffei's ColorAdjust system automatically monitors and corrects even minor color variations during compounding*



*The innovative ColorAdjust system combining a color-measuring instrument based on photo-spectrometer technology with the machine control system ensures precise and reproducible colors (Photos: KraussMaffei)*

tion of reclaim material. This will save not only time and money, but above all valuable raw materials.

## Sustainable production with fully automatic color correction during compounding

KraussMaffei's ColorAdjust system comprises two units: A spectral photometer determines the color of the cooled reclaimed pellets in the vibration chute and transmits the corresponding results to the machine control system. These values are used to control the color metering unit that is equipped with at least four colors and four metering devices. Upon request, the system can be expanded to six colors to flexibly cover the entire color spectrum that the human eye can distinguish. The color can generally be added in masterbatch or liquid form. The ColorAdjust system adjusts the colors fully automatically without any

operator intervention. Thanks to its integration into the twin-screw extruder control system, it can be operated easily from the central control panel.

## From insulin pen caps to automotive door modules

At the KraussMaffei booth in Duesseldorf, interested visitors can get a live experience of the entire material cycle: from polypropylene virgin material used in the production process via re-compounding right through to the finished reclaimed material. The PX 200-1400 injection molding machine equipped with a 96-fold tool produces insulin pen caps from PP. On the downstream mill, these caps are subsequently shredded to regrind. The resulting reclaimed material is transferred by appropriate conveying systems into the ZE 28 BluePower twin-screw extruder in UltraGlide version with a processing section length of 44 D. Thanks to the UltraGlide feature, the screws can be removed automatically from the processing section for cleaning purposes, while the extruder with its ideal ratio between screw volume and torque ensures optimum melt homogenization and color dispersion. Glass fibers and additives as required for applications in the automotive industry, for instance, can be incorporated via additional gravimetric loss-in-weight feeders.

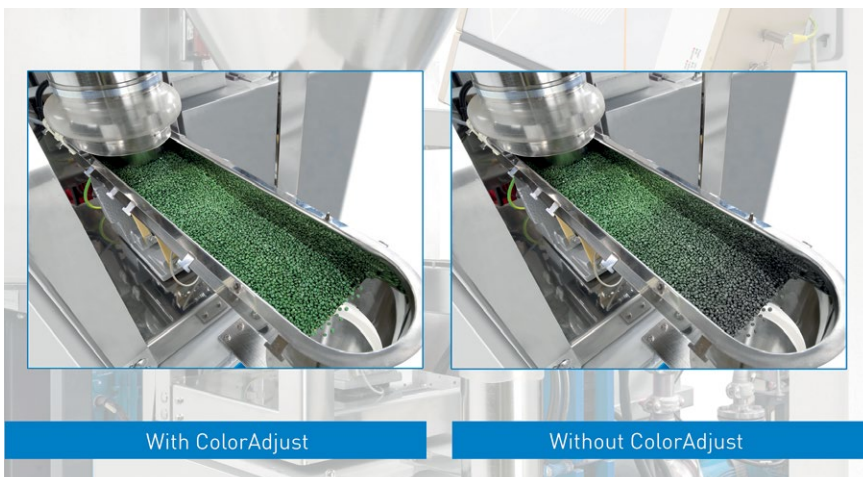

With ColorAdjust

Without ColorAdjust

► KraussMaffei  
[www.kraussmaffei.com](http://www.kraussmaffei.com)

K 2022: Hall 15, Stand C15/C24-D24



# Masterbatch and Compound Solutions

**M**odern Dispersions, a leading global supplier of thermoplastic compounds and concentrates, will highlight its latest developmental work with nanocarbons to boost the performance of masterbatch and compound solutions at the upcoming K 2022 exhibition.

The company continues to undertake research and development work with new grades of carbon black, graphite, and nanocarbons to improve thermoplastic compound properties such as color, UV resistance, and electrical and thermal conductivity. Due to the lower filler loadings required with nanocarbons, better physical properties can be achieved with these types of compounds.

“We’ve had a lot of interest from OEMs and processors and our ongoing project sampling is promising,” according to Jan Kozma, vice president of sales and marketing for Modern Dispersions.

One of the developmental grades contains graphene oxide which is undergoing testing to assess certain property enhancement features including electrical and thermal conductivity, in-

creased tensile strength, and improved barrier properties. The developmental grade is targeted for fibers and films.

Modern Dispersions will also showcase its extensive product portfolio including black masterbatches, wood-polymer composites (WPC), and color concentrates. The company has decades of experience in producing a wide variety of black masterbatches, concentrates, and compounds that provide superior UV protection, FDA compliance, high-jetness, blue-tone, high loadings, low-tint performance, and customizability.

The company also specializes in conductive masterbatches which contain high loadings of carbon black which can be diluted into a variety of polymers to impart electrical conductivity. These masterbatches allow the compounder or processor to easily incorporate the desired level of masterbatch resulting in the targeted finished resistivity level. Typically, these masterbatches comprise between 30 and 60% of the overall resin content.

In wood-polymer composites, Modern Dispersions offers custom for-

mulating with loadings of PE-based WPC between 40% and 50%. These composites can be natural or custom colored. Color concentrate and color compound products are designed to meet market demands and end-use requirements. Capabilities include improved batch-to-batch consistency and film grade organic and inorganic pigment dispersions. The company has extensive color and formulation expertise to deliver consistent products for automotive, construction, packaging, film, molded parts, and engineered plastics. These materials are used to manufacture products such as agricultural film, electrostatic dissipative housings used in electronic packaging, cell phones, fabrics, and household items.



➔ **Modern Dispersions, Inc. (MDI)**  
[www.moderndispersions.com](http://www.moderndispersions.com)  
 K 2022: Hall 5, Stand C06-01

 **2022 Booth B19**  
Hall 16

battenfeld-cincinnati 

**Solutions for circular economy –**  
 Process engineering for efficient plastics extrusion of tomorrow.

- PVC-free flooring boards
- Significantly higher specific outputs
- Excellent sheet thickness tolerances

**Board extrusion –**  
**MultiTOUCH Roll-Stack**

- Total 6 tons/h
- PP with up to 60% filler
- Thickness 1-6 mm

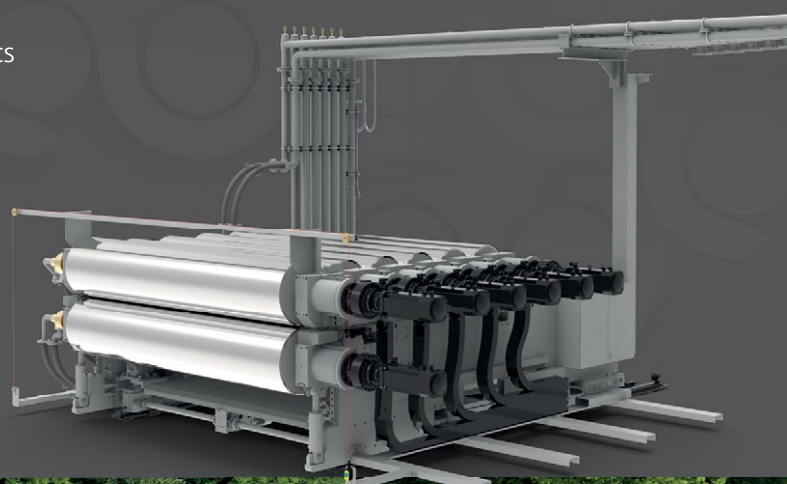

**Sustainable Solutions Worldwide.**

[www.battenfeld-cincinnati.com](http://www.battenfeld-cincinnati.com)



# New Lines for Single and Double Output Pipes Offering Enhanced Performance

**B**ausano has announced that it will be attending K 2022 – It is the perfect setting to introduce industry professionals to the increasingly high-performing Smart Energy System for cylinder induction heating, which helps to reduce energy consumption significantly. The system will be on display at the stand on both a twin screw extruder from the Nextmover range and on the new single screw extruder E-GO R, designed for recycling plastics.

More precisely, the Smart Energy System designed by Bausano features forced-cooled induction coils with special openings that allow air to pass through and the temperature sensor to be installed. The coil is wrapped in highly insulating materials to minimise heat loss from the cylinder to the outside. Moreover, thanks to its innovative internal design, the cooling airflow is channelled directly onto the plasticising cylinder for faster cooling compared to resistive systems. These features can be summed up as follows:

- Even heat distribution and lower coil surface temperature;
- Quick heating up to 250 °C;
- Extremely accurate temperature control thanks to reduced thermal inertia.

Specifically, the Nextmover extruder, equipped with Smart Energy System, will be on display at the trade

fair, along with a double output head for pipes manufacturing PVC pipes. Bausano intends to show visitors how, thanks to its technology, the overall productivity of 2,000 kg/h can be achieved for diameters from 63 mm to 160 mm while saving 35% energy.

Other essential factors for the success of the entire process are the cooling and calibration benches, made of stainless steel for pipes that are cut perfectly to size and have a flawless surface. Specifically, the line with a double output head, showcased at K in its complete configuration, has two 9 m dual-chamber parallel calibration benches with temperature and water level control, which allows for creating different vacuum conditions as required. In addition, the high-performance pipe cooling system cools the pipes more quickly, thus improving their quality and taking up less space when installing the line.

On the other hand, thanks to the 4.0 control system covering the entire line, Digital Extruder Control, with a 21-inch screen, the consumption during each stage of the process can be accurately monitored. The real-time performance display enables intervention to manage motor power, temperature, oil control unit inspection, screw adjustment and other parameters on request. Furthermore, the line meets



the Smart Factory vertical integration requirements, allowing communication with third-party systems, such as the sophisticated in-line measurement tool to accurately check the pipe's internal and external diameter and wall thickness.

Ultimately, K will be an opportunity to launch, for the first time in Europe, the groundbreaking E-GO R technology, which can be used to feed highly contaminated plastics back into production processes. Some examples are HDPE waste from containers for milk, motor oil, shampoos and conditioners, soap, detergents, and bleach. Other applications include PP waste from lunch boxes, yoghurt pots, syrup and medicine bottles, caps and LDPE waste from cling film, shopping bags, and squeezable bottles.

► Bausano & Figli S.p.A.  
Bausano [www.bausano.com](http://www.bausano.com)

K 2022: Hall 16, Stand B70

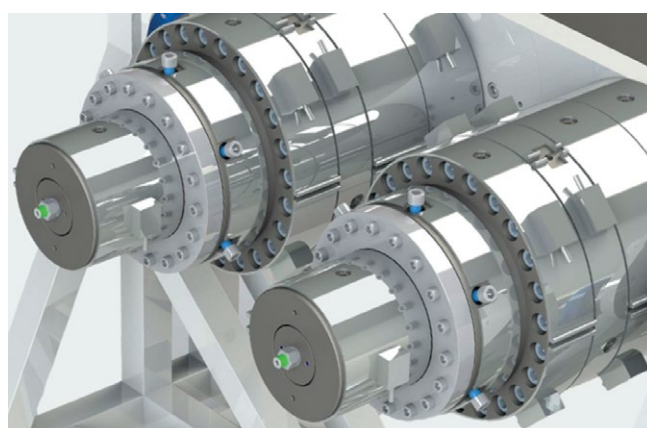

Create. Future. Together.

**COME**  
and see  
**MORE**  
at K-SHOW



# Less Energy, Less Material and Circularity for the Packaging and Carpet Industries



*PET and PP physical foamed trays from sheet made on MEAF extrusion line*



*Artificial grass is another product for which MEAF can provide an extrusion line to produce recyclable backing*

At K2022 MEAF Machines will demonstrate its extrusion solutions. Thanks to its highly efficient design, MEAF's extrusion have a 30 to 65% smaller carbon footprint than many of its competitors while allowing for a further reduction in raw material use. In addition its in-built flexibility allow MEAF's extruders to work with almost any thermoplastic material, including biopolymers and recycled materials like bottle flakes and post-consumer regrind, thus helping plastics processors to go 'green'.

Manufacturers in the food packaging sector are under huge pressure to reduce the amount of plastics used, while still maintaining food safety, attractiveness and recyclability. By partnering with Swiss manufacturer Promix Solutions, MEAF has added physical foaming capabilities to its extrusion lines. This allows for a further reduction in material use and lower weight,

without compromising on features such as stackability and strength. Thanks to the use of nitrogen rather than the often used butane and propane, the process has almost no environmental impact.

An industry sector which only recently has started to move towards a 'greener' future is the carpet and artificial turf sector. Where previously they would use non recyclable materials like bitumen and latex, they are now looking at switching to thermoplastic elastomers (TPE) and TPU for their carpet backing to allow for their products to become fully recyclable rather than being incinerated or ending up in a landfill. This however requires a considerable switch in the production process and a new way of thinking for many carpet manufacturers, reason for MEAF to adjust its in-house extrusion test line for various carpet backing solutions.

Energy and material efficiency have always been at the heart of MEAF's design philosophy. This has helped to company to gain a foothold in far-away places where reliable energy and raw materials come at a premium. "That is the advantage of being a relatively small company," says Elwin Houtekamer, Director at MEAF Machines BV. "We are more agile than the big manufacturers and work as equal partners with specialised innovative suppliers. This way we are always at the forefront of extrusion technology."

➔ MEAF Machines  
[www.meaf.com](http://www.meaf.com)

Hall 17, Stand A22

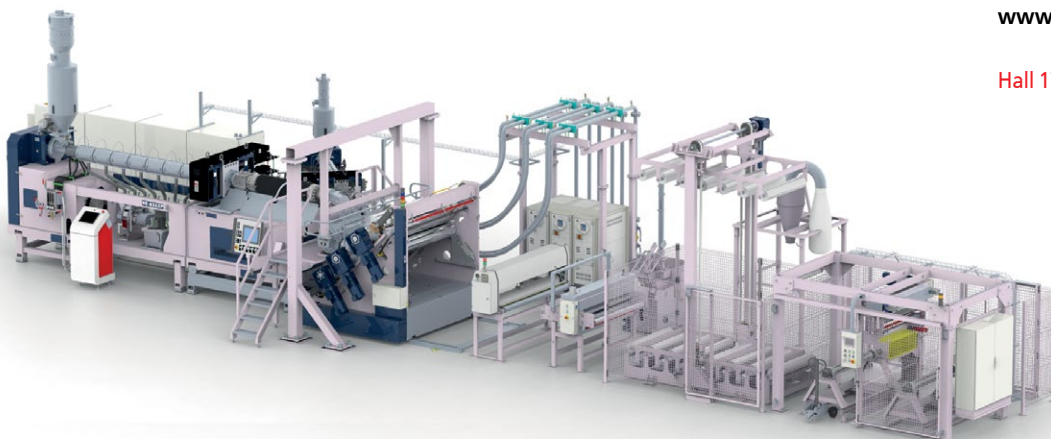

*MEAF 90mm co-extrusion line for (foamed) rigid sheet production  
(All pictures, source: MEAF)*



# High-Efficiency Technologies for Processing and Recycling Plastics

At K 2022 Coperion and Coperion AK-Tron will be presenting a variety of new and ongoing developments that will markedly increase the efficiency of plastics compounding processes, help boost conscientious resource handling while at the same time achieving very high product quality. Moreover, the company is creating a space dedicated to the forward-looking topic of "Plastics Recycling". Coperion will be exhibiting an entire production line for recycling polyethylene terephthalate (PET) at their booth within the VDMA's Circular Economy Forum, a pavilion on the open-air fairgrounds. Exhibits will encompass bulk solids handling, feeding, extrusion, and pelletizing, all representing Coperion's advanced expertise in numerous plastics recycling processes such as chemical recycling,

multilayer film recycling, and upcycling. Trailblazing new developments from Coperion, such as the ZS-B MEGAfeed side feeder that enables plastic film and flake recycling in very high throughput dimensions, will be center stage at the Coperion Recycling Pavilion.

One eye catcher at the Coperion booth will be the high performance ZSK Mc18 extruder with a 70 mm screw diameter. With its high specific torque of 18 Nm/cm<sup>3</sup>, it is especially suited for efficient compounding of plastics at very high throughput rates and with comparatively low energy consumption. The ZSK extruder is equipped with a ZS-B easy side feeder as well as a ZS-EG side devolatilization unit. Both the ZS-B as well as the ZS-EG – thanks to their simple design – significantly



The Coperion STS 25 Mc11 laboratory extruder impresses users with the same advantages as the STS Mc11 series, demonstrates a simple design, is user friendly and can be cleaned easily (Photo: Coperion, Germany)



The **LARGEST** Diameter in **PVC-6**

Easier installation

High ductility

100% recyclable

Full watertight

Unbeatable physical and mechanical properties

From DN90 mm to DN1200 mm

From PN12,5 bar to PN25 bar

**TOM**  
DN1200 mm



2022  
19-26 October  
Düsseldorf  
Germany

Visit us!  
Hall 16  
Stand B17

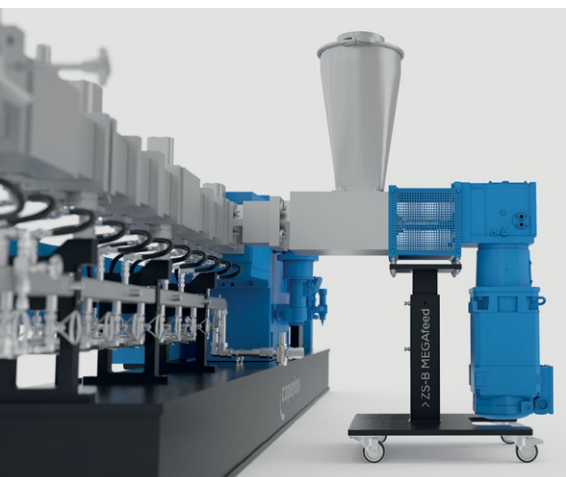

*Thanks to its high intake potential, the recycling of plastic fiber and flake using the newly developed ZS-B MEGAfeed side feeder from Coperion becomes much more economical or even possible in the first place (Photo: Coperion, Germany)*

K-Tron is very robust, and thanks to its good price-performance ratio is an economical solution for reliable feeding of free-flowing bulk materials.

The SP series dual bearing strand pelletizers have been given a comprehensive facelift; Coperion's SP340 model will represent this development at the K booth. In comparison to the previous model, the new SP strand pelletizer allows even faster recipe and color changes. The cutting chamber works with absolutely no dead space; thanks to its quick-release function, the cutting unit can be swapped out quickly and easily. The pelletizer's interior has improved accessibility and is very easy to clean.

One further highlight of Coperion's showing at K 2022 will be the ZXQ 800 rotary valve. This high performance valve, which works with especially low gas leakage, was developed by Coperion especially for powder intake into pneumatic conveying lines at up to 3.5 bar. Thanks to its enormous capacity, it is very well suited for systems planned for polyolefin manufacturing in the future.

As a raw material, plastic can make a valuable contribution to environmental protection and to the energy revolution. Key to both is the efficient recycling of plastics. For this reason, plastics recycling is the focus of comprehensive development projects at Coperion. The company will show the results of these projects at K 2022 in its pavilion on the open-air fairgrounds (CE09)

reduce the time needed for recipe changes or maintenance tasks, since they can easily be removed from the process section in just a few steps. A K3-ML-D5-V200 vibratory feeder from Coperion K-Tron will be on display at the main intake of the ZSK 70 Mc18. The ZS-B easy will be equipped with a K-ML-SFS-BSP-100 Bulk Solids Pump™ (BSP) feeder.

Another highlight at the Coperion booth will be the STS Mc11 series laboratory extruder with a 25 mm screw diameter. It stands out with its simple design, user friendliness and easy cleaning. Its Do/Di of 1.55 and specific torque  $M_d/a^3$  of 11.3 Nm/cm<sup>3</sup> allow for safe scale-up across the entire STS Mc11 series. The STS 25 Mc11 will be exhibited with a Coperion K-Tron K-ML-SFS-KT20 twin screw feeder.

Moreover, the new, preconfigured ProRate PLUS feeder line will be available to view in all three available sizes: small, medium, and large. This continuous gravimetric feeder from Coperion

within the VDMA Circular Economy Forum. There, Coperion will present its combined process solutions and technologies for the economical recycling of various plastics while achieving the highest levels of product quality. At the center will be a system built around a ZSK 58 Mc18 twin screw extruder configured for manufacturing high-quality PET using recycled materials.

For feeding voluminous flakes and fibers (PET and other plastics) efficiently into the ZSK twin screw extruder, Coperion will show the SWB-300 Smart Weigh Belt Feeder with a S100 single screw pre-feeder, as well as the new ZS-B 70 MEGAfeed side feeder. The SWB is an extremely reliable gravimetric feeder from Coperion K-Tron that can process large volumes of bulk materials with a wide variety of flow properties at very high accuracy. Using the innovative, newly developed Coperion ZS-B MEGAfeed, plastic recycle with a bulk density under 200 kg/m<sup>3</sup>, long considered intake-limited and thus not worth recycling, can be reliably fed in large quantities into smaller sizes of Coperion's ZSK twin screw extruders and be concurrently recycled and compounded.

Melting, intensive devolatilization, and complete homogenization take place in the process section of the ZSK 58 Mc18, before the material stream is transferred via a gear pump and filter with an automatic screen pack changer to an underwater pelletizer for pellet production. Finally, the pellets are condensed in the SSP (Solid State Polycondensation) reactor and can then be processed again into bottles, fibers, or films. The high quality of recycled PET manufactured using this innovative Coperion process was approved by the U.S. Food and Drug Administration (FDA) for direct contact with food (letter of non-objection).

Conventional technologies for recycling PET require pre-drying and crystallization of flakes and fibers before they can be re-processed. Using Coperion's technological process solution, PET recycle can be intro-



*The ZSK 70 Mc18 twin screw extruder that Coperion is presenting at K 2022 has a 70 mm screw diameter and is equipped with numerous features that improve handling and enable increased efficiency in compounding and recycling (Photo: Coperion, Germany)*





The SWB-300 weight belt feeder from Coperion K-Tron is an extremely reliable gravimetric feeder offering high accuracy and efficient process control (Photo: Coperion K-Tron, Switzerland)

➔ Coperion GmbH  
www.coperion.com

K 2022: Hall 14, Stand B19  
Pavilion on the open-air fairgrounds: CE09

duced directly into the ZSK extruder. Recyclers profit particularly from the very high end product quality. Thanks to the ZSK's very good devolatilization properties, volatile components such as monomers, oligomers and water are reliably removed. Savings in operating and logistics costs as well as reduced energy consumption are further advantages of Coperion systems for recycling PET.

If the plastic pellets produced create undesirable odors, these can be reliably removed using deodorization equipment from Coperion. In order to optimize such deodorizing equipment's specification and to individually determine its operational parameters, Coperion now provides onsite tests using a mobile unit for reducing plastic pellet and recyclate odor at customers' production facilities. Using this solution with freshly produced product and under actual production conditions, the possibilities for reducing recyclate odor can be thoroughly investigated, and system parameters to achieve desired product quality can be defined on location. Coperion will exhibit this mobile deodorization unit in its Recycling Pavilion.

Marina Matta, Team Leader of Process Technology Engineering Plastics at Coperion, said: "Plastics recycling is one of the core topics that we are emphatically promoting in order to better support the plastics industry on its path to a circular economy. We are very proud of our newly developed technologies and processes that achieve first-class product quality and make plastics recycling significantly more efficient. The innovative ZS-B MEGAfeed makes recycling of some plastic film and flake even possible in the first place. With our new Recycling Innovation Center, we will soon have the optimal environment for developing further technologies and working together with our

customers to optimize recycling processes. We're awaiting completion of the Recycling Innovation Center with excitement and great anticipation."

# COMPLETE SYSTEM

COMPEO compounding technology  
– the heart of customized systems.

**Join us**  
K 2022, Düsseldorf  
October 19 – 26, 2022  
Hall 16 Booth A59

### Complete Compounding Solutions

BUSS is a worldwide leader in providing complete solutions for demanding compounding applications. With a long history of meeting the needs of a diverse customer base, BUSS offers expert consultation, planning, engineering, and innovative products. The COMPEO as the heart of the compounding line ensures maximum performance and unrivaled flexibility resulting in superior product quality.

www.busscorp.com





# Technical Solution to One of the Biggest Challenges in the Processing of Recyclate

The line manufacturer Reifenhäuser Blown Film has developed a technology that makes blown film producers independent of highly fluctuating recyclate qualities and ensures a stable production process – even when processing low-quality input material: EVO Fusion upgrades recyclate qualities.

With EVO Fusion, blown film producers also process previously unusable, lowest-quality recyclates into high-performance blown films for simple applications, such as trash bags or mailing bags. Until now, such low-grade recyclates could only be used for simple and thick-walled injection-molded products. In addition, producers can make higher-quality film from recyclates that could also be processed in the past.

Eugen Friedel, Director Sales at Reifenhäuser Blown Film, explains, "In order to drive the circular economy, recycling content in blown film products must increase and classic downcycling must be limited. With EVO Fusion, we offer a unique process that enables customers to process even low recyclate grades easily and economically



*Thanks to the twin screw and degassing unit, the EVO Ultra Twin Extruder can also safely process low-quality recyclate. The system can be degassed very easily and effectively to remove unwanted components in the recyclate*

into high-performance products and increase the recyclate content. In this way, processors open up new fields of application for recycled products."

The EVO Fusion process relies on direct extrusion, which eliminates the need for energy- and cost-intensive regranulation of the raw material. This means that fluff (film shreds) and all types of production waste and PCR material can also be processed directly.

This is made possible by the twin-screw technology, which homogenizes the melt better and thus ensures a



*Screws and barrels from Reifenhäuser Reiloy regularly set benchmarks in wear protection and offer proven longer lifetime*

stable process. In addition, processors can degas the system very easily and effectively, removing unwanted components in the recyclate.

For processing better quality regranulates, Reifenhäuser recommends the EVO Ultra single-screw extruder. Thanks to optimized barrier as well as shear and mixing parts, this extruder processes recycled material as reliably and naturally as other raw materials – the ideal prerequisite for success in the growing market for products with a high recycled content.

## Highly Wear-Resistant Screws and Barrels Enable Safe Recyclate Processing

Whether film manufacturer, injection molder or line manufacturer: the processing of recyclate involves many challenges because recyclate is a rather complex raw material and a stress test

*Recyclate is complex as a raw material and a stress test for the components of the plasticizing unit. Abrasion, corrosion and adhesion can lead to surface damage*

for the plasticizing unit. Highly wear-resistant barrels and screws from Reifenhäuser Reiloy give the unit a long service life and ensure high product quality.

Recyclate is often a grab bag, because it is not always clear how carefully the starting material has been sorted and cleaned, or which additives and

possibly aggressive residual components are contained. In addition, high-quality recyclate processing requires special additives that enable the polymer to become a high-quality product again. However, many of these additives are also challenging because, among other things, they have an abrasive effect or adhesive tendency -

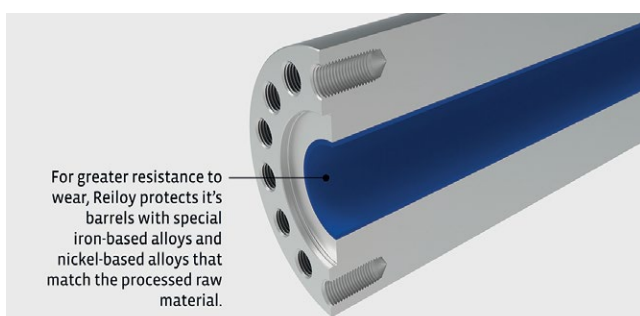

For greater resistance to wear, Reiloy protects its barrels with special iron-based alloys and nickel-based alloys that match the processed raw material.





*With EVO Fusion, even fluff (film snippets) and all kinds of production waste and PCR material can be directly processed into functional films for applications such as trash bags or mailing bags (All pictures: Reifenhäuser)*



and that the investment pays off – because high-quality components need to be replaced less frequently, produce consistent quality and thus ensure the productivity of a line."

Reifenhäuser Reiloy has decades of experience in wear protection systems and takes a holistic approach to wear

protection consulting: Reiloy experts determine the optimum interaction between barrel and screw armor for each plasticizing unit and select the appropriate surface treatment.

➔ Reifenhäuser Group  
reifenhäuser.com

K 2022:  
Reifenhäuser main booth: Hall 17 / C22  
Reifenhäuser screws, barrels and extruders: Hall 11 / C16  
Reifenhäuser flat dies: Hall 1 / D91

others have an aggressive effect due to inorganic acids. Many colorants and fillers also stress the components.

Reifenhäuser Reiloy offers a reliable solution for this with its highly wear-resistant screws and barrels and regularly sets benchmarks in terms of quality and performance. The components offer a demonstrably longer service life, precise matching of raw materials and additives, exclusive alloys developed in-house, and process-optimized surfaces. Manufacturers of injection molded and extruded products thus benefit from the best cost-benefit ratio in the industry. Higher resistance to wear is provided by special iron-based alloys and nickel-based alloys that match the raw material being processed. The decisive factor here is the composition of the alloys, because wear protection depends not only on the hardness of the layer.

Ralf Pampus, Managing Director at Reifenhäuser Reiloy, explains: "We are the only screw and barrel manufacturer to develop and produce the hard material alloys - and even the powders required for wear protection – in-house in our own materials laboratory. This means we offer expertise across the entire process that is unique in the market. Recent independent tests have again proven that Reifenhäuser Reiloy's wear protection is the best on the market

## INLINE INSPECTION, SORTING & ANALYSIS OF PLASTIC PELLETS

**PURITY SCANNER ADVANCED**  
Unique in the marketplace

- Down to 25 µm – detects the smallest contaminants
- Combination of optics and X-ray – spots optical impurities & metal contamination
- Stainless steel vibration chute – operates wear-resistant for clean material transport

Video link

K Düsseldorf  
Booth 10 F14

www.sikora.net



# Sustainability Strategies for Packaging Stakeholders

OMV Technologies, a leading global manufacturer of thermoforming machines, molds, and inline extrusion systems, will showcase its latest technologies and sustainability efforts which are supporting processors and brand owners in their transition to a circular economy. As a leading provider of turnkey manufacturing solutions, the company will highlight its successful sustainability practices for the packaging industry at the K 2022 exhibition.

“We take our responsibility as stewards of the environment very seriously and we’re committed to helping our customers meet the growing demands for more sustainable packaging,” said Mark Strachan, CEO of OMV Technologies.

The OMV line of closed-loop machinery solutions is a reflection of the company’s commitment to sustainability, according to Strachan. OMV is directly responding to the market forces that are demanding new sustainable material and processing options. Specifically, Strachan pointed to state and federal legislation on single-use plastics, growing consumer demand for sustainable products, and the firm commitment from

brand owners to achieve sustainability goals over the next five years.

“We deliver expert knowledge and leading-edge technology for those manufacturers who seek to adapt and modify their existing lines amidst the changing landscape in the packaging market,” said Brooke Maltun, President of OMV Technologies.

OMV has worked closely with its customers throughout the design and development phases to ensure their products meet current legislation that requires the use of higher percentages of post-consumer recycled plastic. The company has forged partnerships with processors and brand owners to incorporate up to 100% post-consumer recycled (PCR) resin into products, thus diverting plastics from landfills. OMV’s unique processing technology incorporates the PCR flake while meeting all of the necessary functional demands and industrial food-grade requirements.

OMV’s ability to build its own extruders offers a distinct advantage to processors who can acquire a tailor-made solution built around the end product. These machinery con-

figurations - incorporating the latest in drive, screw, die, and downstream technology - are more energy efficient and less costly. In addition, the latest automation technology is playing a major role in maximizing production, particularly as manufacturers continue to grapple with labor shortages.

OMV is focused on the development and production of lightweight packaging that has a low carbon footprint. The company is committed to significantly increasing the use of recycled materials and driving the circular economy worldwide. In its own business operations, the company is in the forefront of energy-optimized equipment and highly sustainable operations and facilities.

Among its efforts to promote sustainable packaging, OMV is working with multi-national brand owners to develop single-source, mono-material solutions as a replacement for multilayer structures when possible.

► OMV Technologies Inc.  
[www.omvtechnologies.com](http://www.omvtechnologies.com)

K 2022: Hall 3, Stand B-05

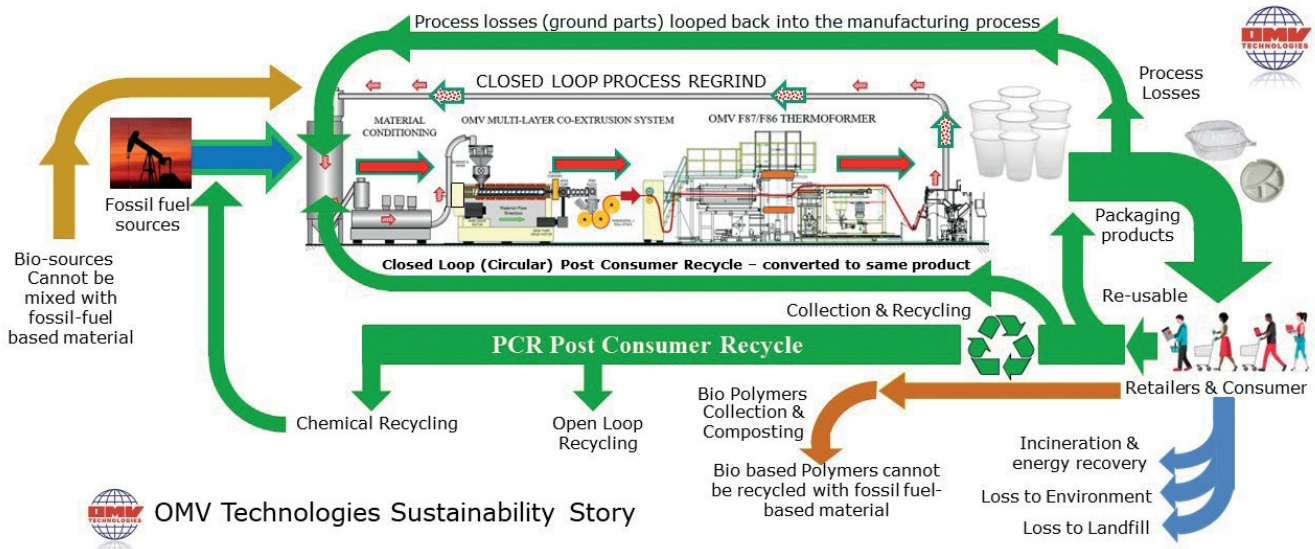



# New Anti-Fouling Additive for the PP and PE Polymerisation Process

Palsgaard has announced the introduction of an efficient new plant-based, food-grade anti-fouling additive for the polypropylene and polyethylene polymerisation process. The new product, Einar® 981, has been developed to remove severe concerns about the ethoxylated amine chemistry currently used. Einar® 981 will officially be introduced to the market at K 2022 in Düsseldorf, Germany.

Einar® 981 is supplied as a clear and easily pumpable liquid for use in existing dosing systems. It eliminates static

*Einar® 981 is a plant-based, food-grade anti-fouling additive for the polypropylene and polyethylene polymerisation process (Photo: Palsgaard A/S)*



build-up during polymerisation and prevents fouling of the reactor wall, thus helping PP and PE producers maintain the cooling efficiency of the reactor. Building on Palsgaard's proven chemistry of renewable anti-static polymer additives, it provides high anti-fouling efficiency at low concentration (100 to 300 ppm) without any negative effects on catalyst mileage, productivity or final polymer performance.

The active compound of Einar® 981 is a polyglycerol ester (PGE) blend of fatty acids derived from RSPO[1] certified sustainable palm oil. As a non-toxic and food-contact approved anti-fouling additive, the product offers a drop-in regulatory compliant solution to replace incumbent ethoxylated amines and can also be used as a more efficient alternative to sorbitan monooleates. This makes it an ideal process additive in the polymerisation of PP and PE materials for sensitive applications, including e.g. medical devices and baby food containers.

"Polyolefin producers are under growing pressure from converters and brand owners to abandon the use of ethoxylated amines in their polymerisation processes and switch to safer products without any regulatory concerns," says Ulrik Aunskjær, Global Business Director, Bio Specialty Additives at Palsgaard. "Einar® 981 is our answer to meet this challenge with a highly sustainable, renewable and food-grade anti-fouling process aid that demonstrates our expertise in customer and market focused renewable polymer additives."

Einar® 981 is produced in CO<sub>2</sub>-neutral facilities and will be commercially available worldwide.

[1] Roundtable on Sustainable Palm Oil, [www.rspo.org](http://www.rspo.org)

► Palsgaard A/S  
[www.palsgaard.com/polymers](http://www.palsgaard.com/polymers)

K 2022: Hall 7, Level 1, Stand D20

## The Planetary Roller Extruder Revolutionary process engineering



Visit us!  
16 | A42  
2022

Follow us!

[entex.de](http://entex.de)

# Efficient All-In-One Plastics Recycling Solutions

As a pioneer in the recycling industry, Lindner draws on a wealth of experience in transforming waste into valuable materials and stands for quality, experience and product innovations. At K 2022 Lindner will be presenting ground-breaking all-in-one solutions for the efficient plastics recycling of tomorrow.

The circular economy and the growing importance of plastics recycling under the umbrella of climate protection are key topics at October's K in Düsseldorf. Undoubtedly, there has been an upswing in plastics recycling for several years. The challenges facing the industry, however, continue to be multifaceted and complex: demand on recycle quality is increasing as is the call for higher throughputs with minimal energy consumption and maintenance. The driving force behind this is clear: Plastic needs to be retained in the cycle for as long as possible and the aim is also to use recycled plastic material increasingly in the food sector. The key to recycling success lies in the perfect coordination of the upstream processes of shredding, washing and sorting. As one of a few recycling specialists, Lindner offers all-in-one solutions to effectively optimise these steps while processing rigid plastics, film and PET.

Shredding waste plastic is right at the start of the plastics recycling process – an area in which Lindner can apply its decades of experience in the processing of domestic, commercial and industrial waste to obtain standard throughputs of 40 t/h and more. At the K 2022, Lindner will be presenting the upgraded Jupiter BW series for the first time. This product innovation is focused on optimising the handling of plastic films for the downstream NIR sorting process. In addition to a constant volume flow and homogeneous larger particles, this also includes optimising the particle size for NIR sorting. "With a particle size of DIN A4 to A3, we have been able to improve the performance of the NIR systems with our customer," says Stefan Scheiflinger-Ehrenwerth, Head of Product Man-

agement at Lindner. "Every shredding process generates a certain proportion of fines along with the targeted ideal particle size. With the new, resource-efficient Jupiter BW set-up we have managed to reduce the proportion of fines generated by 50%, which manufacturers of NIR sorting equipment have confirmed." As a result, the newly developed cutting system of the Jupiter BW series is able to significantly increase the added value along the chain.

Besides shredding and sorting, the washing process is also a key quality criterion for producing high-quality regranulate. Not an easy challenge if you consider that plastics are increasingly extracted from waste streams, which is how heavily contaminated input materials are gradually finding their way into plastics recycling. "We are only too familiar with the problem. But we also have the right solutions," says Harald Hoffmann, Managing Director of Lindner Washtech, Lindner's subsidiary specialising in plastics recycling. "Our patented Rafter pre-wash has been tailored to the new requirements. By using a larger rotor, we can lengthen the dwell times, which obviously has a positive effect on the depth of cleaning. We have also been able to sustainably improve the throughput rate, 3 t/h for films and 5 t/h for rigid plastics – and we will be showcasing this product innovation at the K trade fair for the first time," adds Harald Hoffmann. Lindner will also be highlighting another product innovation, this time in thermal drying: "At the K we will also be introducing EcoDry, our new thermal dryer. Clever use of

heat exchangers and a sustainable insulation of the material-conveying components means this dryer achieves energy savings of up to 30 %. And the high degree of drying also ensures the flakes are better prepared for subsequent processes."

As in 2019, Lindner is in the outside area of the K, and this year the company will be exhibiting as part of the VDMA Circular Economy Forum. Showcasing its products together with several other companies along the entire value chain will give visitors a taste of the circular economy, promoting this important topic. As an example of an entire washing plant, Lindner will be presenting a shredding, washing and drying unit with integrated water treatment and will be recycling plastics live several times a day.

Shredding is performed by a model from the new Micromat HP series – a machine equipped with new convenient functions that offer impressively high throughput performance and ease of maintenance. Its flexible, bolted knives system and its enhanced drive make the new Micromat HP series an energy-efficient all-rounder in plastics recycling, and can be used to shred films and rigid plastics.

► Lindner-Recyclingtech GmbH  
www.lindner.com

Hall 9, Stand B17 & B19  
Circular Economy Forum in the  
outside area CE-02



Shredding – Washing – Sorting:  
At K 2022 Lindner presents efficient all-in-one  
plastics recycling solutions at Booth B17 & B19  
as well as in the outside area CE-02 as part of  
the Circular Economy Forum

# Weigh Scale Blenders (WSB) Series Added

Maguire will debut the new WSB-600 series blender at K 2022. This new series of gravimetric blenders for mid-range throughput applications precisely dispenses up to twelve materials of widely diverse types and can be configured to dose up to six major ingredients.

Growing demand for the use of post-consumer content, surcharges on virgin resin and global legislative policy proposals & adoptions are being enforced around the globe. These new challenges have plastics processors looking for economical solutions to incorporate additional materials, more diverse materials and changing material content in their final product. The WSB Series of blenders allows unmatched flexibility to handle up to 6 major components such as multiple PCRs, Virgin or Regrind.

The new Maguire® Weigh Scale Blender (WSB) 600 Series has a throughput range up to 2,500 lbs/hr and is suitable for injection, extrusion, blow molding, and central blending applications. The WSB-600 adds another model to

Maguire’s robust line of Weigh Scale Blenders, which already includes over 150 configurations suited to every process and application requirement.

The WSB-600 Series blenders can dispense up to twelve different components including pellets, powders, and liquids to poorly flowing ingredients like regrind, flake, wood flour and talc filler. Each ingredient hopper has a dispensing device designed for a material in a specific form. Like the larger units in the WSB family, the new blenders can be outfitted with up to six large-component slide gates for dispensing major ingredients, along with any combination of large corner valves (11,000 g/sec), 4-inch vertical valves (2,000 g/sec), 2-inch vertical valves (400 g/sec), auger feeders, and liquid color pumps.

“By providing the same flexibility as the 1200, 2400 and 3000 Series units for dispensing up to six large-component ingredients, the WSB-600 Series blenders enable processors working in a somewhat smaller throughput

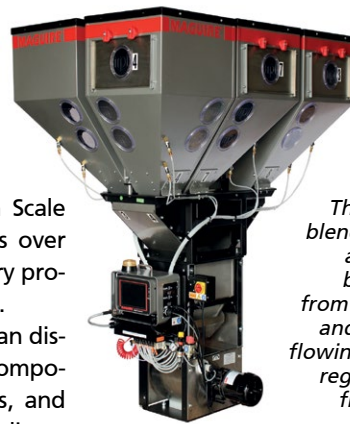

*The WSB-600 Series blenders can dispense as many as twelve batch ingredients, from pellets, powders, and liquids to poorly flowing ingredients like regrind, flake, wood flour and talc filler*

range to meet growing demand for products that incorporate regrind and PCR along with virgin resin,” said Frank Kavanagh, Vice President of Marketing and Sales. “And like all Maguire blenders across the throughput range, the 600 Series WSBs provide batch-to-batch accuracy of 0.1%.”

Maguire has an installed base of well over 60,000 WSBs since it first introduced the gravimetric blender in 1989. All Maguire WSBs are backed by an industry leading 5-year Warranty.

➔ **Maguire**  
[www.maguire.com](http://www.maguire.com)

K 2022: Hall 10, Stand C41



## Our Vision - Sustainable Innovation!

BeOne global and diverse Kautex team, together with customers and partners, to create leading change and added value!



Join us in the BeOne World of Sustainable Innovation

Meet us at K 2022

**Hall 14 booth A16/A18**



Schedule your #KautexExpert meeting right here

Kautex Maschinenbau GmbH  
 Kautexstr. 54 | 53229 Bonn  
 T +49 (0) 228 / 489-0  
 info@kautex-group.com  
[www.kautex-group.com](http://www.kautex-group.com)



OUR WEBSITE





# Leading Plastics Recycling Towards a Circular Economy

For a long time, our economy has been dominated by a linear approach under which raw materials are manufactured, processed, used once, and thrown away. But the future calls for a circular economy in which we reuse our products and recycle them efficiently at the end of their life. And that holds true for plastic as well. This is not a new topic, but it is one that has been gaining ground in recent years.

While we recognize and appreciate the numerous applications and long-life cycle that plastics delivers, it is precisely these properties that sometimes generate challenges when recycling. Due to the experience and knowledge gained over 25 years in the plastic recycling market, FIMIC knows all about recycling processes and what is really needed for efficient plastics recycling as part of a circular economy. With this know-ledge and a clear vision of its mission worldwide: the protection of the environment through the proper recycling of plastic and its optimal reuse, FIMIC returns to K 2022 with a 76 m<sup>2</sup> stand based on the concept "Choose the future for your child". The idea to take an active part in choosing a sustainable future for future generations, will be narrated through a 3d video where the RAS melt filter is the protagonist. In this edition of the K Fair, FIMIC will have its entire team of experts, nine regional sales managers from all continents will give personal consultation to visitors, four technicians will be available for mechanical details about FIMIC's melt filters technologies.

This year FIMIC will focus its participation on the promotion of social and environmental awareness for the achievement of a real circular economy of plastics. As companies in this sector, the company also has the duty of giving advice to the customers and in this period, also to those

who want to enter this world, with little experience in the sector.

Based on their experience and based on the material to be processed, FIMIC does not recommend the same filter based on just the type of material. The historic RAS melt filter has reached the serial number 430. Versatile melt filter, sold all over the world, allows to handle the dirtiest materials on the market. To give some indications the company has come to remove 15% of paper, but obviously if talking about more aggressive contaminants, the percentage is drastically reduced. In the case of metals or soil for example, it is reduced to 1% in order to work safely, with little risk of breakage or wear.

In fact, the customers generally use 1 to 2 lasers per month, but those customers who decide to use the melt filter to eliminate very high percentages of contamination, due to a poorly performing or non-existent washing, pay obviously much more for the filter maintenance. And the waste increases. In fact, the percentage of plastic waste generally is around 1%, but if we increase the contamination, the waste can also increase proportionally. RAS don't need prefilters and reaches up to 2 tons of LDPE or HDPE with a single laser or punched screen, (different according to the filtration needed).

In the event of an increase in hourly production, the GEM takes over, to reach up to 3 tons of LDPE or HDPE, obviously based on MFI or filtration. In this case we are talking about a TWIN filter, as the filter area of the RAS 700 (almost 4,000 cm<sup>2</sup>) has been increased by 35% with only two screens. GEM 600 in fact has 5500 cm<sup>2</sup> with only two screens.

In the case of very high and probably aggressive contaminations, there is also the possibility of installing the ERA, a melt filter with two filtration chambers. This allows to avoid



to have two filters in the same line, because ERA filters twice with in a single screen changer.

RAS, GEM and ERA are therefore recommended for materials defined as post-consumer, while in this case, if we want to talk about post-industrial, the development of a filter suitable for automatic but very fine and sensitive filtration has recently been completed. The TEN in fact uses the mesh belt, which is perfect for the filtration of low contaminated materials (max 1%) and small in size. The TEN was recently installed in Italy and like many meshes, a manual protection filter was recommended to the customer to avoid excessive consumption of the mesh for contaminations exceeding a millimeter.

To complete the product range, in 2021 FIMIC also launched a new product, SPA. A pump dedicated to the world of recycling, as it avoids gears and use a single screw. In this way, a protective pre-filter is avoided and extremely low maintenance costs are achieved. SPA will be installed this year in Japan and Saudi Arabia on two twin screw extruders, and of course it will be our job to inform you of the results immediately afterwards.

► FIMIC Srl.  
www.fimic.it

K 2022: Hall 9, Stand B35

# Plastics Shredding Gets Even Smarter

**H**ellweg Maschinenbau will be presenting extended options around the Smart Control system for its entire granulator range at K 2022. Also presented at the show will be a digital central lubrication unit with Bluetooth data transmission retrofittable to all central granulators together with a new edge trimming system for use in extrusion which is now servomotor-driven, so enabling optimum control.

Hellweg has added a hardware module to the Smart Control system that is capable of storing the power consumption of the machine it is fitted to over the long term, for example over a financial year, and providing it for analysis. Together with the ability to display power peaks, it provides valuable data for optimizing energy use.

The software itself now has the option of controlling granulator speed in increments of one, so giving the user even more flexibility in tailoring machine parameters exactly to requirements. The SECURE+ package for the control system adds safety features. As soon as it detects imminent granulator overloads on the basis of motor current and torque values, it counteracts them so that rotor blockages can virtually be avoided.

Hellweg can now optionally equip all central granulators from the 260 series

upwards which are used for grinding sprues, sheets, molded parts, sprue slugs and hollow items with a new central lubrication unit. Using a Bluetooth interface, the unit provides the operator with all relevant data, such as battery voltage, temperature, delivered lubricant volume as well as the time since the most recent pump stroke, operating time and number of pump strokes. The integrated, active reporting system enables the operator to detect irregularities at an early stage and nip them in the bud. With an eye to sustainability, Hellweg also offers the option of refilling empty cartridges as part of its exchange service.

The new R 200/20 Servo edge trimming system, a joint development with BREYER Extrusion, complements Hellweg's range of systems of this

*The consumption measurement now available via Smart Control provides a valuable basis for optimising energy use (© Hellweg Maschinenbau)*

type, also known as guillotines or chippers. When trimming film webs, it pre-shreds one or two edge strips, which are then fed to a granulator for further processing. Its servo gear motor means that cutting cycle times can be freely specified. The operator can use the touch display to select the cutting frequency for the trimming and so specify the length of the chopped edge strips at a constant cutting speed.

➔ Hellweg Maschinenbau GmbH & Co. KG  
www.hellweg-maschinenbau.de

K 2022: Hall 11, Stand C39



## rPET recycling solutions

### viscoSHEET

Up to 100 % rPET and inhouse flakes processable at guaranteed iV-Levels for direct food contact.

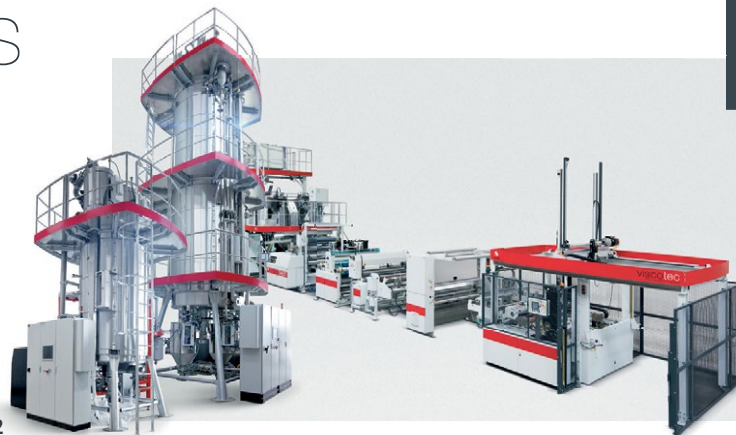

VISIT US AT K  
HALL 16, BOOTH B47-2



Starlinger Group

# Circularity Through Plastics Additives in the Spotlight

At this year's K 2022 Milliken & Company will showcase new measures to advance the circular economy through chemistry – part of the company's 2025 Sustainability Goals. Additionally, Milliken is partnering with more than 30 partners in purposeful collaborations that will be on display throughout the K Show, including its ongoing partnership with PureCycle Technologies, whose patented technology turns recycled polypropylene into virgin-like material.

A glimpse at what will be on display at the booth:

- Millad® NX® 8000 ECO, clarifying agent for polypropylene (PP), boosts clarity, enables faster production rates and reduces energy use.
- DeltaMax®, performance modifiers for recycled PP. This product is unique in its ability to balance melt flow, impact strength, and stiffness to increase overall performance for recycled materials.
- DeltaMax performance modifiers for virgin polypropylene impact copolymers (ICPs) enables resin producers to balance the properties of ICP resins more effectively, while affording them the opportunity to optimize processing efficiencies. DeltaMax also helps converters reduce energy by running machines with faster cycle times or lower temperatures.



Millad® NX® 8000 ECO clarifying agents for PP (All photos © 2022 Milliken & Company)

- DeltaFlow™ Viscosity Modifiers, solid concentrates designed to specifically help PP recyclers by increasing the melt flow rate of recycled polypropylene (rPP) for extrusion and injection molding processes.
- Hyperform® HPN® performance additives for PP which deliver an improved balance in properties between stiffness and impact resistance while reducing energy use.
- UltraGuard™ Solutions which enable downgauging to reduce material usage and part weight while also improving barrier properties in polyethylene (PE), allowing designers to cre-

ate more mono-materials products, improving recyclability.

Many of Milliken's products are designed specifically to yield sustainability benefits. These qualities include: reduced energy consumption and lightweighting, better reuse potential, increased net use of recycled content, improved recycling and recyclability, and the replacement of less-sustainable resins.

Milliken is future-focused and proud to be part of the solutions that will enable the entire industry to advance circularity and boost the percentage of plastics being recycled. To this end, the company is actively engaging in several industry-spanning initiatives, including the Alliance to End Plastic Waste, The Recycling Partnership, the Association of Plastic Recyclers, the HolyGrail project to improve the sorting of waste plastics via digital watermarks, and the RecyClass recycled-content certification program for packaging.

➔ **Milliken & Company**  
milliken.com, k2022.milliken.com

K 2022: Hall 6, Stand A27

Hyperform® HPN®  
performance  
additives for PP



DeltaMax® performance modifiers for  
polypropylene impact copolymer





# Circular Economy and Sustainability

There is a lot to see for visitors at the Brabender stand at this year's K trade fair: Brabender will be presenting its solutions for quality testing as well as for the development of sustainable plastic and rubber products on a laboratory and technical scale. This includes modular torque rheometers with measuring kneader and extruder attachments, as well as compact extruders of various dimensions and devices for special measuring applications in the plastics industry.

In addition to the devices on display, there will also be live demonstrations on site: "Among other things, we extrude recycled plastic pellets from shredded polypropylene at our booth", explains Jessica Wiertz, Manager Applications at Brabender.

## "Circular Economy" and environment in focus

Sustainability and resource conservation have been the focus of the Duisburg-based (Germany) company for many decades. Current projects with partners from research and industry in which Brabender devices are used include the extrusion of sustainable films from algae or the determination of carbon black from recycled car tires with the help of the Absorptometer C. In addition, the use of the laboratory devices saves resources and costs compared to ongoing production with machines, since only a fraction of the amount of raw material is required for the measurement, as would be the case with comparable tests on large-volume machines.

## Modular and compact solutions for rheology and extrusion

Also on the booth is the MetaStation 4E, with which Brabender launched the new generation of mod-



ular torque rheometers at K 2019. Like its predecessor, the Plasto-graph, which is widely used in the industry, the MetaStation 4E serves as a drive for measuring kneaders of various sizes. In addition, the drive has been extended to operate the larger Brabender internal mixers and does not require a docking station. Furthermore, single-screw extruders, the conical twin-screw extruder and the new B-TSE-A 12/36 mini compounder can also be operated with the MetaStation 4E.

Meanwhile, Brabender also offers the MetaStation 8 stand-alone drive, also on display at K 2022. Together with its bigger brother, the MetaStation 16, the two are the successor generation to Brabender's well-known Plasti-Corder Lab station. At the heart of the MetaStation devices is Brabender's Meta-Bridge software. The user interface, which is immediately available without installation, the tracking of measurement results from any location and end device, various data evaluation functions, pre-implemented standards and individually adaptable measurement methods are just some of the software's advantages. It can be operated via the convenient touchscreen, making the operation of external computer peripherals obsolete.

In addition to the modular MetaStations, Brabender will also show

compact extruders, including the TwinLab-C 20/40, with integrated drive at the K booth. As for the modular extruders, different die and screw geometries as well as metering and downstream equipment, including for pellet pelletizing or strand winding, are available for the compact units.

## Optimize vehicle tire formulations

A product innovation at the trade fair is the new 350 SX internal mixer, which Brabender will present for the first time at a trade fair. In combination with a Brabender torque rheometer, the 350 SX analyzes the melting behavior of materials and compounds and is used in the tire industry, for recipe development and research and development. Among other things, it helps to optimize the formulation of tires by mixing the rubber and analyzing the pure rubber. In addition, the effect and behavior of ingredients such as carbon black or silica in car tires can be measured.

## Residual moisture measurement – also for recyclates

When processing high-quality plastics, an important parameter is the water content of the product. With the moisture analyzer for plastics, the Aquatrac V, the water content in plastics, including PET recyclates, can be determined according to DIN EN ISO 15512:2019. Brabender will also exhibit the device for residual moisture analysis at the show and perform live measurements.

➡ Brabender® GmbH & Co. KG  
www.brabender.com

K 2022: Hall 10, Stand A14

# Expanded Product Portfolio and Material Supply Capabilities at K 2022

**P**olyplastics will highlight its expanded product portfolio and material supply capabilities at the upcoming K 2022 exhibition. The company will discuss the latest developments in its DURACON® POM, LAPEROS® LCP, and TOPAS® COC product lines.

With full acquisition by Daicel in 2020, Polyplastics has expanded its options for growth and geographical market coverage. The company has expanded LCP sales to EMEA and the Americas while making timely investments in capacity to better respond to market growth.

The company has announced that its Technical Solutions Center in Raunheim officially opened in April. The one-stop shop serves the technical support needs of its growing customer base in Europe. "This investment reaffirms our continued commitment to the engineering plastics market in Europe," said Yohei Iizuka, managing director of Polyplastics Europe GmbH. "The new technical service operation will support application development work and enable our customers to shape their innovations from concept to commercialization."

At K 2022, Polyplastics will also highlight its expanded global supply capability which includes planned construction of a new polyacetal manufacturing plant in Nantong Economic Development Zone, Jiangsu Province, China. The production capacity is planned to be 150,000 tons in total in

two stages. The new capacity will satisfy growing demand for POM, improve lead times, and reduce transportation costs. The initial start-up of 90,000 tons is expected in November 2024.

Polyplastics's LCP business – buoyed by strong growth in electrical/electronics – plans to construct a new polymerization plant with production capacity of 5,000 tons/yr at Polyplastics Taiwan Co., Ltd. In recent years, LCP market demand has increased due to growing investments in 5G equipment. It is expected that LCP applications will continue to expand with the full-scale adoption of 5G and millimeter-wave devices. Polyplastics is now offering LAPEROS® LCP globally.

Polyplastics will also highlight the strong growth for COC which will be supported by construction of a new production facility in Leuna, Germany. The new plant, to be operated by local Polyplastics subsidiary TOPAS Advanced Polymers GmbH, will have a capacity of 20,000 tons per year, adding significant room for growth beyond the current output. The facility will be operational by latter half of 2024.

COC has become a crucial component in many medical devices based on its outstanding purity and glass-like properties. In packaging products, TOPAS® COC has raised the performance of commodity polyolefins, enabling the development of simpler, better recyclable and sustainable solutions.



Among the latest key material developments are the introduction of PLASTRON® LFT resin which is made of specially formulated regenerated cellulose fibers. The eco-friendly PLASTRON® LFT provides weight reduction plus mechanical strength, enabling manufacturers to reduce their carbon footprint and meet today's sustainability demands.

Eco-friendly resins that incorporate natural fibers, starch, wood powder, and other plant-based and natural mineral filling materials are being considered for use in a broader range of applications. Cellulose is a promising material to help reduce CO<sub>2</sub> emissions but its insufficient strength is a limiting factor. Polyplastics has addressed this problem by using regenerated cellulose in the development of LFT resins with an excellent balance of physical properties.

➔ Polyplastics Co., Ltd.  
[www.polyplastics-global.com/en/](http://www.polyplastics-global.com/en/)

K 2022: Hall 7A, Stand B02

# Sustainable and Efficient Drive Concepts for the Plastics Industry

**B**aumüller will show how energy-efficient drive systems record and lower the CO<sub>2</sub> footprint of the end product. Thanks to clever Baumüller software features, machine damage can be avoided and the emissions increased. Another trade fair display

unit illustrates how the digital twin can be used to design and commission servo-hydraulic drive trains completely virtually. All use cases will be shown live at the exhibits.

A patented trade fair highlight is the servo pump direct "Performance

Line" attachment, which is practically maintenance-free thanks to its self-lubricating internal gearing. Direct attachment also means that the coupling and pump support can be omitted. The resulting shorter installation length enables a smaller machine

installation area. Due to the flexible design of the motor flange, the motor's installation position can be freely selected and adapts to the respective machine design.

The converter series b maXX 5300 includes feed-in and regenerative units as well as drive units, which can be quickly and easily combined by an integrated drive connect system. This allows the machine builder to benefit from low installation costs and short commissioning and service times. The controllers impress with their high power density and very small installation space. The power supply units have been expanded to include peak outputs of up to 300 kW. This is ideal for the plastics sector, because short-term high peak power outputs are often needed for dynamic movements such as the opening and closing of the closing unit.

In addition to the b maXX 5300 side-by-side system, the b maXX 5500 mono units are also available. Power outputs from 1.1 to 315 kW can therefore be covered. The entire bmaXX 5000 series also offers higher safety functions such as SLS (Safe Limited Speed) and SLP (Safe Limited Position) directly in the drive and a large number of cooling options for optimum use.

Water-cooled torque motors impress with their highly compact design and optimal heat removal. Direct coupling achieves high stiffnesses and therefore very good force transfer together with ideal control properties.



Baumüller offers drive systems for servo hydraulic solutions that are low-maintenance and energy efficient (All images: Baumüller)

The execution as a hollow shaft variant improves accessibility and enables media and tools to be fed through. For example, spindle drives can be integrated in a hollow shaft. This enables optimizations in the compact machine construction and in the process engineering.

Several industry-specific drive components are also exhibited on the trade fair stand. One example is a torque motor version with thrust

bearings. These thrust bearing motors were designed for use in extruders. Here the extruder screw is directly coupled with the motor shaft. The motor can therefore be connected in a space-saving and direct way, even under the high prevailing axial forces.

► Baumüller Gruppe  
www.baumuller.com

K 2022: Hall 11, Stand A45

# NEXT LEVEL SOLUTIONS

Integrated Systems for Polymer Processing

- PUMP & FILTRATION SYSTEMS ►
- PELLETIZING & PULVERIZING SYSTEMS ►
- RECYCLING SYSTEMS ►
- DIGITALIZATION ►

MAAG Group is the Partner for the Polymer Processing Industry worldwide. All of our integrated solutions from Pump and Filtration Systems to Pelletizing and Pulverizing systems to Recycling Systems have an outstanding performance for demanding customer requirements.

maag.com

Join us in Duesseldorf, Germany

K-Show  
Oct 19-26, 2022  
Hall 9, Booth A02

a **DOVER** company



# Recycling Pioneer Establishes Closed Loop for PET Food Packaging

*"From niche to must-have." That describes how plastics recycling has evolved in recent years. Faerch also contributed to this. As a plastic packaging manufacturer and EREMA customer in Denmark, Faerch is the first company in the world to successfully integrate the recycling of European post-consumer PET household pots, tubs and tray packaging into its own production process.*

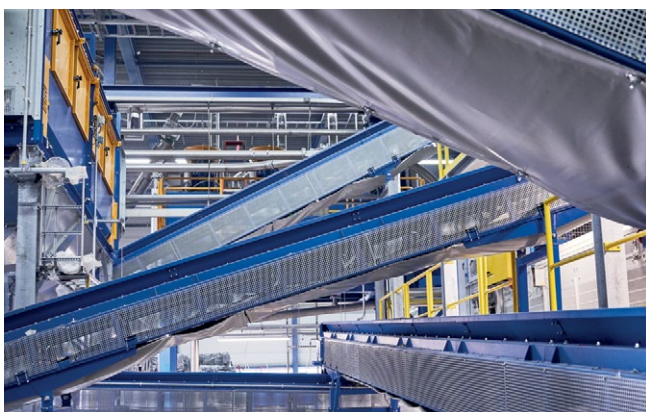

Faerch is recognised as a leading manufacturer of food packaging, largely made from PET thermoforming film. Referred to as trays, they are well suited to many applications, especially in the food sector, where food safety, shelf life and a clear view of the packaged product are needed. Faerch produces trays for ready meals, fresh meat, take-away meals and packaging for dairy products a several of its locations in Europe. They supply well-known food producers and trading companies around the world. The packaging must meet the highest quality standards for direct contact with food, and must meet special functional criteria, such as for transporting liquid food and when food is frozen or heated up in it.

## A closed loop for food trays

The trays Faerch produces are fully recyclable and, depending on the PET type (CPET, MAPET or APET), are made of up to 100 percent recycled post-consumer PET (rPET). That is why Faerch is considered a pioneer in tray-to-tray recycling, also due to its cooperation with EREMA. This is because in comparison to bottle-to-bottle recycling, where the circular economy has been successfully well established for 20 years, closing the material loop of PET trays has lagged behind. "For us it was clear that with purpose-specific modification of our flexible VACUREMA® technology, tray-to-tray recycling could become just as much of a success story. Faerch was our first customer to be as convinced



*At Faerch's own recycling plant "CIRREC" in the Netherlands, PET bales obtained from collection and sorting companies throughout Europe are sorted, washed and recycled. Both post-consumer rPET flakes and pellets are supplied to packaging manufacturers and reused in the company's own production*

of this as we were," says Christoph Wöss, Business Development Manager at EREMA Group GmbH.

At Faerch's own recycling plant "CIRREC" in the Netherlands, PET bales obtained from collection and sorting companies throughout Europe are sorted, washed and recycled. Both post-consumer rPET flakes and pellets are supplied to packaging manufacturers and reused in the company's own production. "This currently makes us the only integrated recycler in the world capable of recycling used household PET packaging on an industrial scale and turning them back into new trays," explains Thomas Bak Thellessen, Senior Director Group Sustainability & External Affairs. He backs up this statement with some impressive figures: Trays from all over Europe are recycled to make 1.2 billion PCR PET trays per year. The aim is to quadruple the recycling capacity within the coming years. "Without any compromises in terms of food contact compliance and functional properties," as Bak Thellessen emphasises:



*Thomas Bak Thellesen, Senior Director Group Sustainability & External Affairs  
(All pictures: copyright: Faerch A/S)*

"Quality and sustainability must go hand in hand for us, because this is the only way we can offer our customers circular packaging solutions and drive the change necessary to establish an infrastructure needed to achieve a real circular economy." To get the PET waste it needs, Faerch offers its own buyback models to customers who are able to collect the packaging again after use, such as airlines and catering companies. "For our production, this waste is a valuable raw material that we know is of the right quality."

**The VACUREMA® recycling process – safe, fast and flexible**

Faerch has been relying on the VACUREMA® system with SafeFlake technology from Austrian recycling machine manufacturer EREMA for the recycling process for the trays since mid 2018. The special feature of this set-up is that decontamination, drying and IV treatment already take place on the flake in the vacuum reactor. Only then

*Trays for fresh meat*



is the material fed into the extruder. This prevents hydrolytic and oxidative degradation of the melt in the extruder, which in turn is a prerequisite for highly clean, food contact compliant rPET trays with the best IV and colour values. The quality of the rPET pellets remains consistently high even if the parameters of the input material – such as moisture, mixture or bulk density – vary. In addition to these quality aspects, the financial arguments also clearly speak in favour of this recycling process. This is because both the total costs of acquisition and use (total costs of ownership) and the energy consumption are comparatively low. "The specific overall energy consumption of a VACUREMA® Prime system is only 0.295kWh/kg. This is one of the best energy efficiency values<sup>1</sup> compared to conventional PET processing lines on the market," says Christoph Wöss.

Plastic packaging plays an important role in the protection and shelf life of food. Sustainable, circular economy solutions can significantly reduce greenhouse gas emissions and food waste. Faerch's tray-to-tray recycling solution shows how the circular economy can work.

EREMA is convinced that many will follow this example in the near future. This is because, unlike just a few years ago, there is now a broad consensus that the circular economy – and therefore recycling – has an important role to play in the transformation into a climate-neutral, resource-efficient and competitive industry.

<sup>1</sup>Source: SKZ – Das Kunststoff-Zentrum, value measured at a throughput of 1650 kg/h, excluding customer's chiller for supplying cooling water.

**EREMA Engineering Recycling Maschinen und Anlagen Ges.m.b.H.**  
Unterfeldstrasse 3, 4052 Ansfelden, Austria  
[www.erema.com](http://www.erema.com)

**Faerch A/S**  
Rasmus Færchs Vej 1, 7500 Holstebro, Denmark  
[www.færch.com](http://www.færch.com)

# Customized Recycling Machines for the Sustainable Processing of Plastic Waste

*For 25 years now, Next Generation Recyclingmaschinen (NGR) has been one of the pioneers in the field of sustainable plastics recycling. The Feldkirchen-based (Austria) company develops and builds customized recycling machines for the sustainable processing of plastic waste and turns its customers' waste products back into ideal raw materials. Fueled by the global demand for resource conservation, the plastics recycling machine specialist expanded its operations in Feldkirchen an der Donau, creating new space for the next generation of recycling machines.*

## NGR develops and builds customized recycling solutions

"As the global demand for recycled plastic increases, so do the quality requirements for the material," emphasizes Wolfgang Steinwender, CEO of NGR. "The more cost-effective, high-quality and energy-saving the reprocessing achieves, the more plastic will actually be recycled," claims Steinwender. For this reason, NGR is working tirelessly on innovative solutions and customized products in the areas of PIR (Post Industrial Recycling), PCR (Post Consumer Recycling) and PET Improvement to provide its customers with distinct market advantages. With the help of pioneering developments in plastics recycling in small-scale applications for "zero-waste production" through to large-scale plants producing up to 3,000 kg/h of recyclate, NGR has made a name for itself worldwide. More than 1,500 machines are already in operation around the globe, saving 350 to 660 metric tons of CO<sub>2</sub> every hour. But the Feldkirchen-based company by no means wants to be satisfied with that. "We are constantly developing new solutions and further benefits for our customers and the environment in order to continue to drive the turnaround in plastics value creation," emphasizes Sven Ortner, Director of Sales

and Marketing. "We are working for a better future and delivering the next generation of highly efficient recycling machines."

## The NXT:GRAN sets new standards – The all-in-one solution for efficient recycling

With this new generation of machines, the name says it all. The NXT:GRAN enables the plastics processing industry to achieve true zero-waste production. It guarantees full value retention of the material and, thanks to newly developed technology, reduces labor and energy requirements to an absolute minimum. With its mission to simplify the recycling of plastics more and more, the particularly maintenance-friendly NXT:GRAN also relies on so-called "ONE-STEP technology" which, in contrast to conventional recycling systems, allows plastic waste to be reprocessed in a single highly efficient step. Material shredding, extrusion and granulation can be handled by a single system, and upstream shredding processes and conveying equipment are eliminated, saving not only space but above all energy. This technology, patented under the name shredder-feeder-extruder combination, also reduces problematic dust formation and has revolutionized plastics recycling. In addition to the increased cutting capacity in the shredder, the NXT:GRAN provides additional power through an optimized material feed to the extruder, which is positively arranged to the extruder screw. This unique design achieves a significant increase in output across the entire material spectrum. The extra high-quality recyclate recovered can be fed directly into the manufacture of a wide variety of new end products, thus saving



**SHREDDER-FEEDER-EXTRUDER COMBINATION –**  
The NXT:GRAN combines shredding, feeding and extruding in a single, highly efficient operation (ONE-STEP technology)



raw materials, reducing the CO<sub>2</sub> footprint and optimizing manufacturing processes.

However, NGR has identified potential for improvement not only in post-industrial materials, but also in the field of PET reprocessing and is tackling used PET bottles with new technologies.

**Next Generation also in PET Improvement – The Future of PET Recycling**

Since PET materials such as empty bottles, films, or textile fibers are also valuable raw materials for the manufacture of new products, the specialists from Feldkirchen offer a revolutionary solution. With the Liquid State Polycondensation (LSP) process, a completely new possibility has been developed under the trade name P:REACT for reprocessing PET waste into food-grade material making use of an extremely efficient process.

While conventional PET reprocessing methods change the material properties in the solid phase, taking many hours, the decontamination of the material in the LSP process takes only a few minutes. In this innovative process from NGR, PET is reprocessed in the liquid phase, which guarantees simultaneous upgrading of the plastic and recycling to the highest standards of brand owners. With melt phase reprocessing, the company exceeds regulatory requirements towards food grade (upcycling) and has created a unique selling point in the global market. Impurities and hazardous substances stored in PET, such as benzenes, are almost completely removed, taking PET recycling to a new dimension. The material properties, which are chemically degraded during reprocessing, can be completely restored, and even improved, by the LSP process. As a result, the processor receives a recycled material stream of the same high quality as is generally expected from the original granulate (virgin material). Brand owner tests confirm that, if required, the material properties after the LSP process are even higher quality than those of the input material. Food grade approvals by the FDA (Food and Drug Administration - USA) and the EFSA (European Food Safety Authority) certify that the LSP process produces the most suitable recyclate for 100% food contact. Due to the extraordinary cleaning performance, the processed PET can easily be recycled multiple times and thus saves further valuable resources compared to virgin PET or energy than other packaging materials such as glass.

*The new energy-efficient NGR plant in Feldkirchen/ Donau (Austria) offers sufficient space for innovations and individual solutions to further advance the recycling economy (Photo © Kurt Hörbst)*



*The future of PET recycling - LSP: Liquid State Polycondensation – The PET recycling machine P:REACT is revolutionizing PET reprocessing*

**Plant expansion: new space for the next generation of recycling machines**

In order to continue to increase plastics recycling rates worldwide under the slogan "Working for a better Future" and to be able to offer ever more efficient machines for its customers, more than 10 million EUR was invested in the expansion of the Feldkirchen site. Near the company's headquarters in the Feldkirchen industrial park, a new, energy-efficient operating facility was built offering over 10,000 m<sup>2</sup> of space for the next generation of recycling machines. "Just as with the machines produced by NGR, the use of renewable energies and maximum energy efficiency are also at the forefront of the site expansion," explains Erich Fürst, COO of the company. "For energy efficiency, we use both groundwater heat and the heat output of our machines to heat or cool the premises. As a result, we don't need a secondary energy source." Through intelligent planning and a sustainable energy supply concept, the company thus saves 288 tons of CO<sub>2</sub> annually. The first building, which was constructed 15 years ago, is also being redesigned and equipped with sustainable technology. In the process, a completely new plastics laboratory was set up and extensively equipped with the measuring and analysis techniques needed to compare and evaluate the plastic qualities of the starting and end products. In a demonstration center set up especially for this purpose, customers can fully evaluate the equipment and convince themselves of the quality of their newly obtained raw materials.

**Next Generation Recyclingmaschinen GmbH (NGR)**  
 Gewerbepark 22, 4101 Feldkirchen, Austria  
[www.ngr-world.com](http://www.ngr-world.com)

# Company Foundation – With German Machines Into The Recycling Future

*It is the largest single-line recycling plant that Herbold Meckesheim has set up to date: In Düzce, Turkey, a PET washing plant designed for the Futurapet company and built last year has now gone into operation. Futurapet is a spin-off of the consumer goods corporation Engin Group and based in Istanbul. The agreement with Herbold Meckesheim to build the recycling line also marked the founding of Futurapet 2020.*



A centerpiece of the PET recycling plant is the hot washing step  
(All pictures: Futurapet/Herbold Meckesheim)



Set-up of the assemblies for the Futurapet line

The Engin Group describes its spin-off for the recycling of plastic waste based on cutting-edge technology as “one of the important investments”. In accordance with the “sustainable future vision”, the return of the plastics to the commodity cycle is intended to prevent environmental damage and make a contribution to the national economy, the umbrella group points out. Oğuz Engin, General Manager of Futurapet and member of the Engin Group's Board of Directors, emphasizes, not without pride: “We already recycle six million PET bottles a day.”

The factory in Düzce, some 200 kilometers east of Istanbul, targets on a daily output of 90 tons, or put differently the equivalent of an annual production volume of over 30,000 tons of recyclate. In the short time of its existence, Futurapet has already established itself as a well-known producer of high-quality PET flakes, which are used for films as well as for bottle-to-bottle production.

The modularization of its plant concept with standardized assemblies enabled Herbold Meckesheim to implement the construction smoothly and quickly. Some modules were scaled up for Futurapet to achieve the required throughput. In addition, a step drying system was integrated into the hot washing process to increase quality. “The plant sets a new standard in recyclate quality, performance, yield and economic efficiency”, underlines Managing Director Werner Herbold.

► Herbold Meckesheim GmbH  
Industriestr. 33, 74909 Meckesheim, Germany  
[www.herbold.com](http://www.herbold.com)

K 2022: Hall 9, Stand B34



*Thanks to a high degree of automation, the line can be conveniently controlled*



# Global Approach, Italian Roots

*Subject-matter expertise, competence and innovation are the pillars that have guided the Moretto business for over 40 years in pursuing a fundamental goal: to satisfy customer requests, to exceed expectations, to be the ideal partner in the supply of automations for the plastics processing industry.*

**P**assion, ideas, values and people characterize Moretto story. A story of reliability and experience. Who chooses Moretto can rely not only on product quality and process optimization, but on a partner who puts the customer and his needs at the first place; able to provide a quick, detailed and concrete response that allows to increase the value and obtain tangible results in terms of technology, productivity and energy savings. A success that stands out for its ability to constantly innovate by taking up the challenges of our time.

An approach that distinguishes also the K fair. The 2022 edition themes – digitization, climate change and circular economy – are familiar to Moretto and guide the company in providing specific solutions for the smart factory that ensure energy consumption containment and able to process not only virgin raw material, but also PIR and PCR ones.

## Technology Made in Italy

Moretto is recognized all over the world for the quality and reliability of its solutions. Products conceived, designed, developed, assembled, tested and improved in the Italian headquarters with obsessive attention to detail. “To be competitive on the market, it is not sufficient to be a good manufacturer, it becomes essential to supply functional, flexible, cost-effective and environmentally friendly equipment that offer the operator a user-friendly experience. What moves our business activity is the certainty to offer a machine realized according to the customer needs, involving him in the study of it. When a product is placed on the market it must leave a mark”, says Renato Moretto, President of the company.

To achieve this, it is necessary to invest in innovation, focusing on research and development of new technologies. Being innovative means providing more competitive solutions, being pioneer in the sector, raising a challenge every day. Moretto responds to this need with a dedicated



R&D department with cutting-edge tools and highly qualified personnel able to simulate processes and dynamics for the design of exclusive and customized solutions that anticipate market needs. 168 patents prove the company willingness to innovate with exclusive products that represent a must on the market.

## Sustainability and energy saving precursors

Moretto has faced the issues of sustainability and energy saving for several years when it was realized that after raw materials the second expense cost was energy. In the following years, the need to work in the direction of the circular economy was consolidated in order to protect the planet and reuse plastic materials in several production cycles. From this point of view, the market is very demanding in terms of skills and services and the processors are more and more looking for advanced equipment able to work not only with virgin materials but also with high percentage of recycled ones. Global regulations and events push for an increase of use of these materials and their enhancement. It is therefore essential to provide solutions that make possible to reduce the use of exhaustible resources and flexible solutions for the recovery of recycled material. These needs guided Moretto to undertake a research and design project that leads to the development of countless solutions that contribute to the correct and effective treatment of the recycled material at every stage of the recovery process. “Our customers are more and more sensitive to the environmental issue. To satisfy their competitive and sustainable needs it is essential to invest in research to develop new technologies that guarantee efficient and low energy consumption production processes” says Silvia Moretto, Moretto Marketing Manager.

## Connectivity that optimizes processes

Modern production plants are intelligent, flexible and data-driven. The amount of data generated that must be



correctly processed to support decisions and make processes even more efficient is enormous. Having the right equipment for data management becomes essential. MOWIS is the software platform developed by Moretto to supervise and manage the entire production process. A modular and self-configurable tool, usable on-site or remotely, which through the OPC UA protocol creates total connectivity among machines, processes, departments and plants and makes the management of complex systems easy.

### The service that makes the difference

Service, in Moretto business strategy, represents a real commitment to customers. A strategic phase to which the company dedicates high attention, optimizing the equipment use and performance involving specialized and constantly trained technical personnel. Moretto supports customers in every aspect related to the products management and technological content. A service guaranteed worldwide according to 4.0 principles and reachable with a click. Automatic warehouses, software and online platforms facilitate remote assistance, real-time monitoring of activities and the provision of timely interventions in case of need.

Also a digital "identity card" is available for each machine. By scanning a QR code, it makes available a detailed informative sheet. Important information for the operator that allows him to make the best use of the instrument, or-

der any spare parts in real time, find answers to any operational doubts through the dedicated FAQ section.

Technology, sustainability and connectivity will characterize the new Moretto products that will be exposed at the K fair next October as the new dosing and feeding solutions for micro molding and small productions available also for use in the clean room. Thanks to their compactness they can be installed stand alone or on the IMM. Among the solutions dedicated to recycling, Moretto will present the new granulators of the GMK series which ensure uniform and constant granulation minimizing the dust formation. The small size structure allows it to be placed next to the processing machine, thus optimizing production spaces. The implementation of more compact solutions then permit to increase production by reducing energy consumption and noise pollution. Among the novelties also the volumetric doser DVM8 which ensures the maximum perfection of microdosing. This is a small preview of what will be exhibited at the Moretto stand at K 2022.

► Moretto S.p.A.  
Via dell'Artigianato, 3 –  
35010 Massanzago (PD) Italy  
[www.moretto.com](http://www.moretto.com)

K 2022: Hall 11, Stand H56 / H66

# A Success Story – 50 Years of KUNDIG CONTROL SYSTEMS

*Kündig Control Systems (KCS) is a division of the family-owned company Hch. Kündig & Cie. AG (HKC) specializing in thin plastic film measuring and control devices. Since its inception in 1972, the KCS team has steadily climbed its way to being the world leader in the blown film industry.*

It was during the 1971 International Textile Machinery Exhibition (ITMA) in Paris, that it became apparent that the golden years of Switzerland's powerful textile industry would soon be over. Textile machinery was the parent company's core business and the exhibition validated a HKC decision to search for an additional business avenue, a business avenue needed to ensure the company's future. Earlier in 1970, HKC hired a technical salesman and entrusted him with the task of setting up a trading department for machines and equipment outside of HKC's traditional clientele. Instead of textiles, the focus shifted

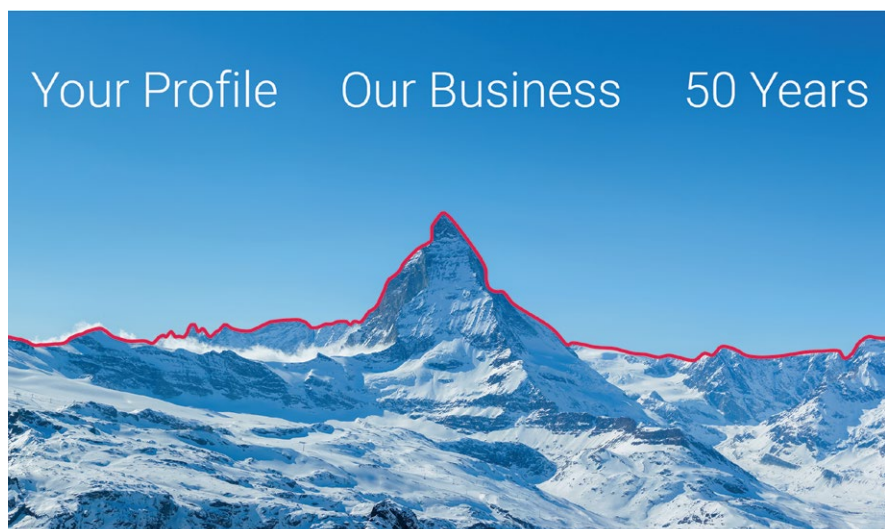

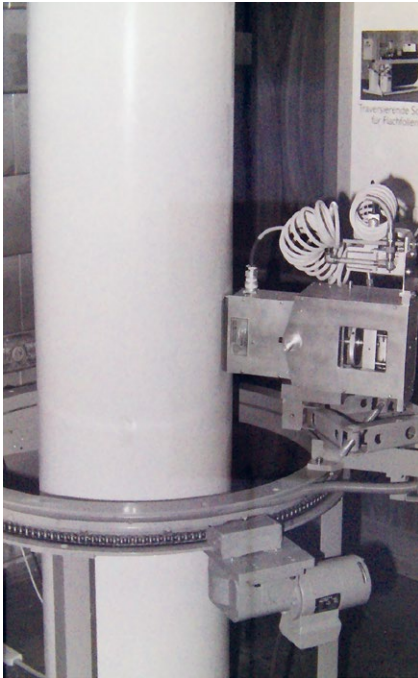

*K-RAY Rotomat:  
Retrofit package from  
gamma-ray to X-ray*

to include thin plastic films. It proved to be the right decision, even though, in retrospect, it was a very ambitious and demanding choice.

The new KCS division got its first opportunity to solve a plastics industry problem during a spontaneous visit to the former Vinora company located in Rapperswil-Jona, Switzerland. Vinora needed a new width control device for blown film extrusion lines to replace the unsuitable devices then available from the Meiners company. KCS decided this was a challenge they would tackle with the added assistance from a young electrical engineer. The first width control device was sold in 1972, thus establishing KCS's foundation for the new division, which is celebrating its anniversary today.

KCS exhibited for the first time at K 1979 in Dusseldorf. The interest in width controls and now, film thickness gauges, was significant. Since KCS did not want to develop and manufacture thickness gauges internally, they made a cooperation agreement with the Winzen company of Minneapolis, Minnesota USA. As time went on, the quality requirements of Europe's film industry began to exceed the capabilities of the sensors procured from the USA.

Therefore, the next new challenge was the KCS's decision to develop their own capacitive thickness gauge. In 1987, the now infamous K-100 film thickness gauge was fully developed and shortly thereafter was sold to all major blown film line manufacturers and end users in Europe and North America. Today, the high quality KCS measurement and control devices of older and newer generations have been in use for years on all continents and their functional efficiency is guaranteed by an efficient customer service department.

Since these beginnings, KCS has continued to develop performance improvements in all its products, testing new scientific findings and developing new technologies. KCS's guiding principal is to offer the world's most innovative measuring and control equipment for the production of very thin, high quality plastic films - which reduce raw material usage. Clearly, an investment in equipment from KCS is clearly both an economic and ecological decision.

At this year's K show, as a world premiere, KCS presents the 9th generation of width measurement and control. For the first time, the FE-9 width measurement uses a new, innovative technology for even more precise foil edge detection. Detailed explanations of this technology are available at booth C51 in Hall 10. As with its predecessor, the FE-9 width measurement system consists of two half-beams in three different sizes, which can be connected to each other at different positions. With only a few different modules, this system enables width measurement of film webs between 10 and over 4000 millimeters.

The CUFE-9 operator console, which is also new, combines 50 years of experience in width control technology with state-of-the-art technology. If the CUFE-9 is integrated into the company network, the system can be completely controlled remotely via a web browser. In addition, width measuring instruments from the 6th generation introduced in 1985 can be connected to the CUFE-9.

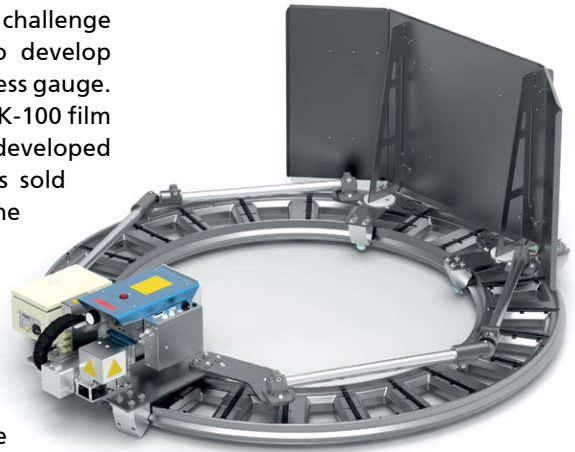

*K-RAY Rotomat:  
Retrofit package from  
gamma-ray to X-ray*

The online film thickness gauge K-XRAY Rotomat KT 3G based on X-ray technology, which was introduced at the last K trade show, is now an established device on the global market. On several occasions, thickness gauges based on a gamma solid-state radiator have also been replaced by a K-XRAY sensor. As a result, thin foils can be measured much more precisely, which, in combination with profile control, leads to decisively tighter cross-profile tolerances.

By no means will the 50-year-old KCS now rest on its laurels. The development pipeline is full to bursting and highly motivated, hard-working employees of the KCS specialist department are doing their best to ensure that new, high-precision, innovative measuring and control devices with the best price-performance ratio will soon be launched on the world market.

Finally, KCS would like to send a huge thank you to its worldwide customers for their good cooperation and their loyal partnership over many years. Without their investments in measuring and control equipment from the KCS, this success story could never have been written.

➔ **HCH. KÜNDIG & CIE. AG**  
Joweid Zentrum 11, 8630 Rüti ZH,  
Switzerland  
[www.gauge.ch](http://www.gauge.ch), [sales@gauge.ch](mailto:sales@gauge.ch)

K 2022: Hall 10, Stand C51

# Smart, Economical, and Sustainable Hose Manufacture

*Extrusion specialist TROESTER stands for high-quality, German-made, development and production of innovative machines for the rubber industry. Hanover-based TROESTER's automatic centering straight heads, crossheads, and double crossheads excel at producing high-quality hoses for all applications. Hose manufacturers welcome the benefits of these extrusion systems. Short start-up processes with minimised wastage and the option to save material due to thinner hose walls make production very economical. At the same time, the raw material and energy savings also reflect the environmentally friendly mindset that underpins all TROESTER developments.*

## Wall thickness distribution in the 1/100 mm range

TROESTER consistently developed manually adjustable extrusion heads and was able to launch and establish an automatic, single-layer crosshead back in 2010. This product has been a success story in hose production. Since then, TROESTER has added to its portfolio and customers can now choose between automatically centering straight extruder heads, crossheads, and double crossheads to improve the quality of their production and products.

TROESTER extruder heads for hose production with automatic wall thickness centering meet all requirements:

- Hose wall thickness centering within 1/100 mm
- Closed loop control with feedback from the X-ray meter
- Greatly reduced start-up scrap due to fast, automatic centering
- Guaranteed wall thicknesses allow a decrease in wall thickness
- Resource friendly, ideal when materials are expensive
- Can be retrofitted and customary tooling systems possible

- Less time required due to automated processes
- Very quick return on investment (less than a year) for a combination of extruder head, X-ray meter and control

## How automated extruder heads works

The tooling is adjustable in X and Y direction, so that the wall thickness is even. The adjustment options for automated extruder heads are similar to those of conventional systems.

The actual adjustment takes place via servo hydraulics. Force is either applied with leverage or the tools are mounted with low friction. As a result, small, careful, and fluid movements without jolts are possible. The adjustment works as a closed loop in conjunction with a wall thickness gauge.

The systems each start with a midpoint setting. As soon as the product has reached the wall thickness gauge, the control system gradually reduces differences in the wall thickness distribution and takes the dead travel between the head and the X-ray meter into account. This initial centering takes place much faster than with conventional ex-

*Straight head*

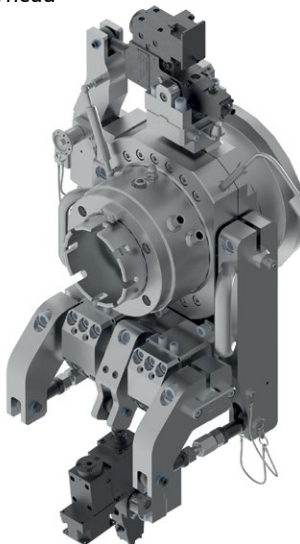

*Crosshead*

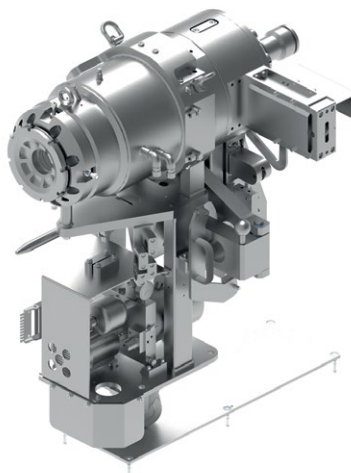

*Double Crosshead*

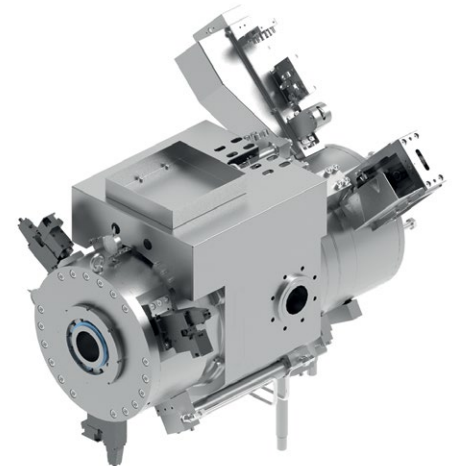



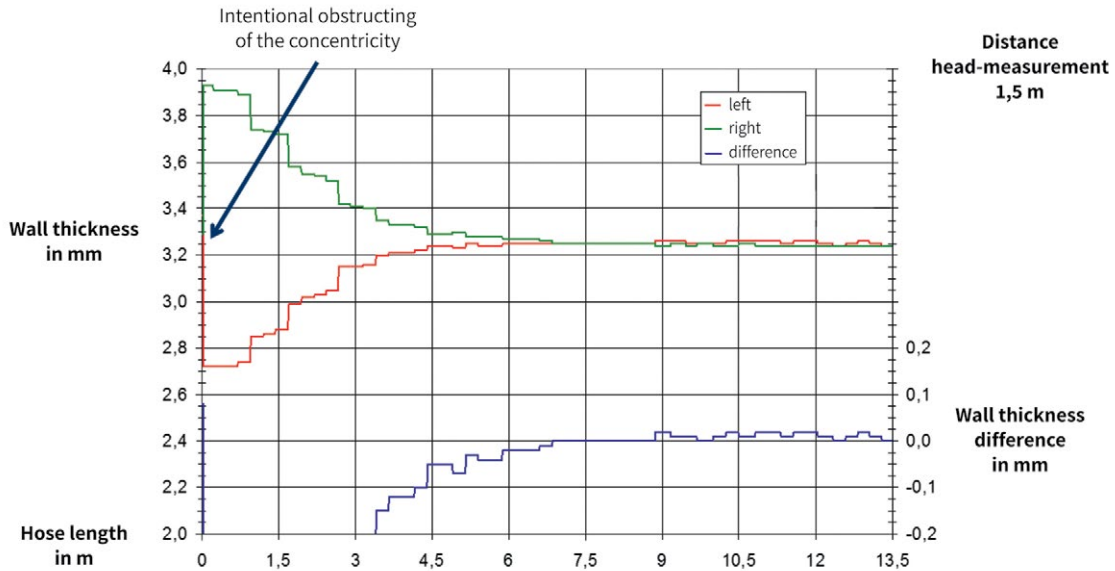

truder heads. During production, the system keeps the wall thickness distribution within a range of less 1/100 mm.

**Conditions**

The hose layers’ wall thickness must be measured consistently online in a defined plane. X-ray meters are suitable for this purpose, some of which are already available for quality assurance and can be integrated into the closed-loop control system. However, without reliable recognition of each of the layers, this isn’t possible. This depends on the physical properties of the compounds, i.e. the attenuation of the X-rays. Prior testing is advisable, particularly where multi-layer hoses are concerned.

**Limitations of the system**

In addition to limited detectability, the system might not work as well if the hose twists. Measurement and adjustment data will then differ. The cause usually lies in reinforcements applied to the hose using spiralling or knitting machines.

*Controlling the wall thickness difference*

As long as the degree and direction of rotation don’t fluctuate too abruptly, this can be compensated for by the control system. Too great a distance between the meter and the head amplifies this effect and leads to slower control. Compensating for mirror-image errors (ellipses) is also impossible.

**Benefits to the customer**

In addition to guaranteed and documented quality, hose manufacturers benefit from saving compound when using the automatic TROESTER extrusion heads on their production lines.

The savings achieved during start-up (due to the scrap saved) and by reduction of wall thicknesses, especially where compounds are expensive, also lead to a very fast ROI of less than one year when a combination of an extruder head, X-ray meter and control is used. The environmental aspects - better utilization of resources and raw materials - are other bonuses on top.

**Author:**

Wieland Hoffmann, Head of rubber machinery and equipment development/TROESTER

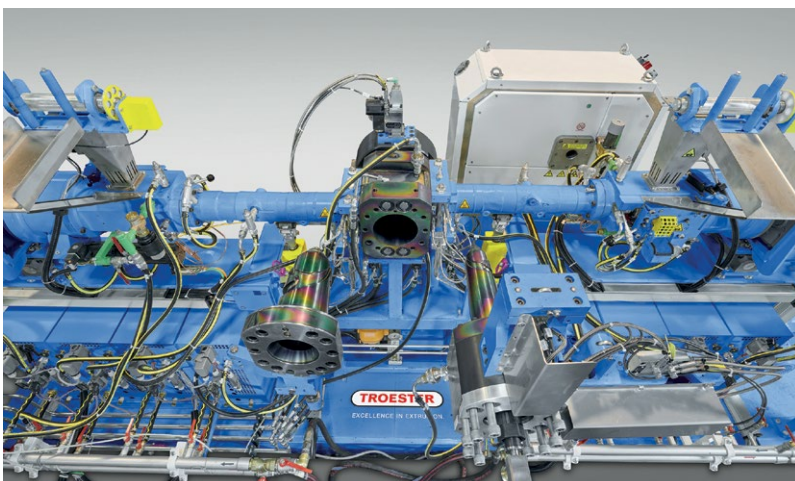

➡ TROESTER GmbH & Co KG  
 Am Brabrinke 1-4, 30519 Hanover, Germany  
 www.troester.de

# Turnkey Extrusion Line for Encapsulation Film for PV Modules

*High Quality Film Requested for Encapsulation Purpose*

*BREYER's extrusion system "CellProtect" allows the production of low shrinkage EVA and POE encapsulation film at high production speed – Another benefit – no energy consuming annealing and no interlayer film makes the production economic and energy saving.*

Photovoltaic (PV) systems are used to convert sunlight into electricity. Energy will continue to be a catalyst for global economic growth and prosperity and the power of the sun is at the heart of the revolution in renewable energy. The global PV market is forecast with a considerable growth in the next few years.

In the same way the demand of encapsulant material is growing. But there is a physical limitation in terms of production speed. Encapsulation film produced on regular extrusion lines has naturally a shrinkage which effects not only the process of laminating but can result in destroyed wafers and therefore creating waste and thus increased production costs.

Especially if such regular lines are speed up in order to serve the high market request, the shrinkage becomes very high. The result is that PV-module producers are faced with a higher scrap rate of modules. Since the regular extrusion systems, using calenders or cast rolls, are limited to a certain speed/output, Breyer is supplying a profitable system for the production of EVA and POE film and other gluey materials – The CellProtect line.

A high quality and low-shrinkage film allows a smooth and fast laminating process. The more shrinkage a film has the more carefully the warm up procedure must be controlled and could increase the laminating time.

With the developed extrusion process of Breyer CellProtect the first time it is possible to extrude EVA film as well as POE at high speed by keeping the shrinkage low. The process avoids tension in the film right from the start. Post annealing systems are therefore not required. In this way the line consumes also less energy.

Encapsulant film producers are faced to a higher profitability by using the new technology since the output is much higher. For the module manufacturers using such low tension film it means that they can run their laminators more stable and as fast as possible.

They will have the advantage of trouble free production combined with a more reliable and efficient manufacturing. Notable module manufacturers are therefore very much interested in getting low shrinkage film.

Cause of the improved properties and performance this EVA film is about to set a complete new standard in the



encapsulation film and its procedure during laminating. Beside of EVA resin also other encapsulant such as POE can be processed. Benefits of POE are a 10 to 20 lower water vapor transmission rate (WVTR) as well as non-yellowing and increased UV and weather resistance.

Furthermore, due to the special designed surface of the film, no PE interlayer is necessary anymore. The rolls can be wound without PE film in between. Also carrying paper which is sometimes used for the manufacturing of EVA film becomes unnecessary.

Regrind material coming from the edge stripes can be processed again. This saves not only costs but also valuable resources.

Finally the process can also be count as "green film production line", since its process saves the interlayer, the carrying paper, has no energy consuming annealing system, a closed loop for the cooling circuit, and works with a low temperature extrusion process.

Several different recipes, like for example fast and ultra-fast cure, were successfully tested by the TÜV Rheinland Germany and will be part for the Breyer Turnkey supply.

A considerable number of systems were sold and installed worldwide.

► Breyer GmbH Maschinenfabrik  
Bohlinger Str. 27, 78224 Singen, Germany

K 2022: Hall 16, Stand D38

# Quality is our Priority

*As a market-leading company for adjustable calibration sleeves, CCA cares for the automation of plastic pipe production with long-term experience and know-how.*

**E**ach calibration sleeve is developed to precisely match the individual production requirements. This means state-of-the-art technology backed by more than 30 years of experience. The results: increased product quality and cost-effectiveness.

### Innovation is our Passion

CCA stands for reliable, high-performance solutions - for pipe diameters of 14 up to 2400 mm. The five different sleeve systems have one thing in common: an adjustment without maintenance-intensive adjustment gears.

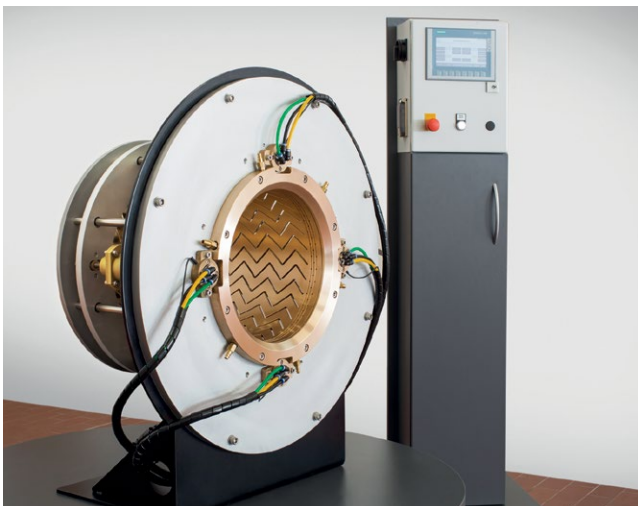

► CCA GmbH  
Werkstr. 10, 32584 Löhne, Germany  
[www.ccagmbh.de](http://www.ccagmbh.de)

K 2022: Hall 10, Stand F34

*The latest CCA development: Motor-controlled calibration sleeve for inline control of the diameter and ovality of the pipe. Starting from an outside diameter of 280 mm to 2400 mm*

### System Overview Conventional Calibration Sleeve

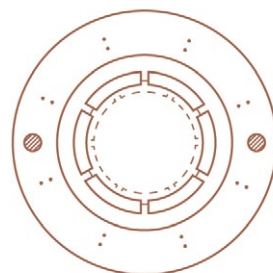
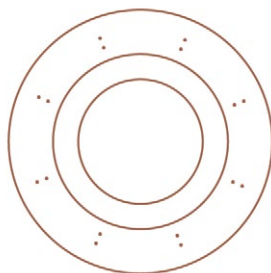

Adjustable Calibration Sleeve  
Two-Point Adjustment

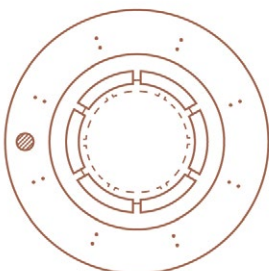

Adjustable Calibration Sleeve  
One-Point Adjustment

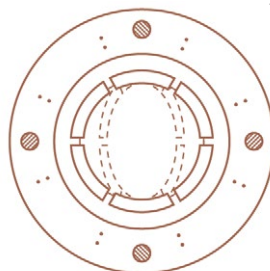

Adjustable Calibration Sleeve  
Four-Point Adjustment

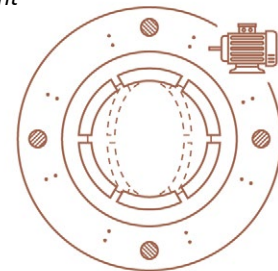

Motor Controlled  
One-, Two- or Four-Point Adjustment



# Compounding of Recycling Plastics Opens Up New Opportunities

*More and more companies are looking for new ideas as to how recycling plastics can be incorporated into end products for consumers and technical components for industry. As a result, compounding is coming more into focus – provided that process stability, high availability and durability of the machines used in the compounding process can be assured.*



MAAG Group  
Recycling Systems

A glance at the shelves in the supermarket is enough – even today you can already find a large number of packagings that advertise a high recycling plastic content, and this share is set to increase even further. It is not only the large manufacturers of goods and articles for the ultimate consumer who are changing over or re-evaluating their processes, but also many other industries.

But changing over a process to enable the use of recycled materials is anything but simple. In the meantime, it has become possible to produce customized recycling plastics even for high-grade applications by adding additives, fillers or reinforcing materials such as talcum or chalk (CaCO<sub>3</sub>), glass fibers or master batch pigments. In view of the fluctuating quality of the input material, however, the know-

how about material properties, wear protection and process stability is more important than ever when it comes to the compounding of recycling plastics. Only then can the property profile of the end product be maintained without compromising quality.

In this respect, raw materials based on recycled material no longer differ much from virgin material in terms of their properties. However, this does have an impact on the pumps, filters and pelletizing systems required for the compounding process. Ultimately different compositions, residual moisture contents and viscosities are the order of the day with recyclates, and various contaminants further complicate the compounding process.

To give just one example: For cost reasons, recycled material is often mixed with fillers, especially talcum or chalk. They can often account for up to 60 percent of the material. The mineral filler has a wear-enhancing effect. Furthermore, higher contamination levels and thus larger particle sizes are involved. Extremely resilient pumps and melt filters are therefore required. This makes it all the more important to have well-matched components in the entire process.

## Each component combines with the next

Maag supplies complete solutions for the compounding process. Here – from melt conveying and filtration

to pelletizing or grinding and drying through to the control system – all the components combine seamlessly with one another to create an efficient production process. The know-how of the entire Maag family with the product brands Automatik, Ettlinger, Gala, Maag, Reduction, Scheer and Xantec goes into the process. These individual elements are brought together into one system, resulting in a complete system downstream of the extruder. The carefully combined unit with the Xantec control concept has coordinated interfaces. It ensures optimum process monitoring and can even be extended to the extruder control system and the dispensing, i.e. to the entire recycling line.

## Vast system know-how

Long service lives, especially when working with recyclates and fillers, are achieved not only by innovative materials and surface know-how, but also by the way the system is operated. To achieve fast start-up and shutdown cycles of processing and compounding extruders, and minimize the load on them, the pressure of the plastic melt is generated by a gear pump. Only with a constant pressure and volume in the process can pellets of the highest quality be continuously produced.

In the Maag melt pump, on the other hand, the material is only briefly pressurized and is subject to very little shearing. The reason for this is that the

Ettlinger high performance  
melt filter ERF1000

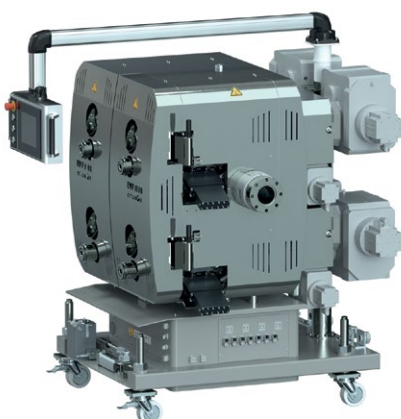

Maag gear pumps operate with very high precision. Depending on the viscosity of the product, they guarantee a tolerance range of a few bar pressure variation. This is ensured by the special gearing and the special geometry of the gear wheels. The precise and stable volume flow rate reduces the extruder's pressure demand, delivering greater efficiency and extended service life, which are highly valued attributes in the recycling industry.

The Maag melt pump was developed one step further for this industry. The extrex6 recycling version looks just like the standard model. This recycling version, however, features special tooth clearances, larger tooth gaps, and new types of bearings protected to prevent large-sized particles penetrating into their lubrication gaps, all of which allows tolerance for particles up to 4 mm in size, depending on the pump rating. In such cases there is no need even for a protective filter upstream of the pump, as a study at a European customer demonstrated over a period of several months. The pump doubled its service life, even in post-consumer recycling – the pinnacle of plastics recycling, as it is where the highest contamination levels are found.

To remove impurities and contaminants from the recycling melt stream and so achieve the desired product quality, Maag supplies the ERF and ECO Series of continuous-running high-performance melt filters. Melt flows from the outside to the inside through a permanently rotating filter drum with a large number of conical holes. The impurities contained in the melt are held back on the filter surface where they are immediately removed by a stripper, fed to the discharge system and discharged from the process. A clean filter surface is therefore available at every rotation.

#### Uniform pellets as a finished product

During underwater pelletizing that combines a number of advantages and innovations in the current Pearlo model, the melt reaches the die plate via a process-controlled, hydraulically actuated start-up valve, where it is forced through die holes into the cutting chamber through which process water flows. The result is a highly uni-

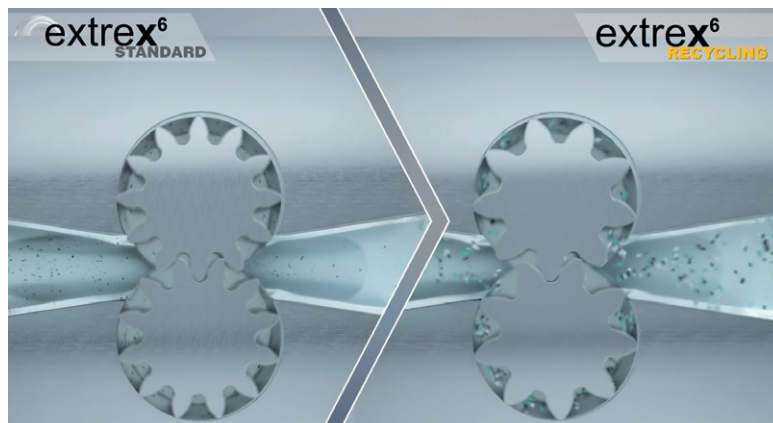

Comparison extrex standard gear pump and extrex recycling gear pump

form spherical pellet. In the downline dryer, 95 per cent of the water is already separated via a pre-dewatering system, with the remaining water then being removed by means of centrifugal separation. The residual heat of the pellets ensures thermal residual drying and thus results in very low residual moisture values. The process water is then filtered and its temperature regulated in the water treatment unit before being returned to the cutting chamber.

During strand pelletizing, the plastic melt is routed to the die head. Here polymer strands are extruded via the die plate and conveyed to the cutting rotor. The exact dwell time in the cooling water is determined according to the polymer, before cylindrical pellets of the highest quality are cut.

#### From floor covering to engine compartment

The systems supplied by Maag are suitable for small pilot lines right up to processes for large throughputs of 12 to 13 tonnes per hour. The latter often run around the clock and are switched off at most once a year for revision. It is therefore all the more important that the systems work very robustly and that the need for spare parts is minimized.

In the meantime, many industries are rethinking the use of recycling materials. For example, floor coverings are usually made of compressed wood fibers, but increasingly they are also being produced with recycled plastics. By contrast with MDF floor coverings, plastic flooring can also be installed in damp rooms. Furthermore it is possible to recycle the laminate at

the end of its life and return it to the material cycle.

Another example is the production of pallets. They have to be particularly impact-resistant and strong in everyday use in order to bear the heavy loads. Recycled materials now make a valuable contribution here, too. Pallets containing recycled material have the same properties as pallets produced from virgin material.

One more example for which Maag supplied a line for compounding of virgin material: This application involves a polymer compound for the production of films. Here, the quality of the later film surface was particularly important. No specks were to be visible caused by gels or agglomerates as residues from the compounding process. The constant-pressure filtration of elastic particles from the virgin material, with enormous, uninterrupted service lives, in combination with a melt pump and underwater pelletizing, is the optimum solution for this customer.

#### Conclusion

The examples show that there is now nothing to prevent the use of recycled material even for high-quality products. However, compounding processes require a great deal of know-how about materials, surfaces and the interaction of the individual systems. Only with carefully matched components, such as melt conveying, filtration, pelletizing and drying, can high-quality pellets and micropellets be produced.

#### Author

Christian Makert / Andreas Liebing  
Maag Pump Systems AG  
Aspstr. 12, 8154 Oberglatt, Switzerland  
www.maag.com

# The Largest PVC-O Pipe in the World – *Molecor at K 2022*

*Molecor will be present at K 2022 in Düsseldorf with its latest innovations. Among them the DN1200 mm PVC-O pipe, the largest in the world and only manufactured by the Spanish company, which is in process of being certified.*

Nowadays, Molecor is present in 5 continents thanks to its exclusive technology and products, a technology based on a Genuine Air System.

In order to improve its own PVC-O system, Molecor invests in Research and Development part of its budget, and it has been recognized with various WIPO PCT registered worldwide.

During the last edition of K fair, in 2019, the company presented the technology with which it manufactures the DN1200 mm pipes, and now, it shows the result. This exclusive technological system, which is named M-OR-P 5012, is the state-of-the-art technology for manufacturing PVC-O pipes in the world.

Molecor increases its fair stand to accommodate the largest PVC-O pipe in the world. This pipeline, with 1200 mm of diameter and its 5.95 m length, is new breaking point for the Spanish company and, above all, for the water sector. Furthermore, this new diameter means a new stage for the transport of water, which becomes more sustainable, widening at the same time, the possibilities for the conveyance of water under pressure.

This new pipe is extraordinary, the largest diameter in the world in this material. It had never been manufactured before, but its size impresses anyone. The exclusive technology of Molecor is the only one in the world capable of manufacturing large diameter PVC-O pipes and it is thanks to the continuous Molecor's commitment on Research and Development.

Focusing on this diameter, due its lightness and its easy installation, Molecor can connect settlements in a



shorter period than other conventional systems. It was the case of Pernik, in Bulgaria, in which the company had to act quickly to recover the potable water service in less than 2 months with its PVC-O products.

In this way, the company offers the largest range of PVC-O pipes in the world, which include nominal diameters from 90 mm to 1200 mm. The last one, as we said before, has never been manufactured before, so don't miss the opportunity of checking its characteristics and advantages in Düsseldorf.

The product range of Molecor is manufactured in different pressures. Thus, you can find pipes from PN12.5 to PN25, always maintaining the characteristics of a class 500 pipe, the highest.

PVC-O pipes enable the replacement of old traditional ones around the world to implement the new material, PVC-O, thus getting a more respectful impact on the environment. In this sense, we must highlight the great chemical and physical resistance of PVC-O, a product guaranteed for 50 years.

This chemical resistance makes possible Oriented PVC be immune to corrosion and natural chemical substances, as well as to aggression from micro- and macro-organisms present in nature. For that reason, TOM® pipes are not degradable and, thus, the quality of the fluid that circulates inside them will always remain unaltered. Ex-





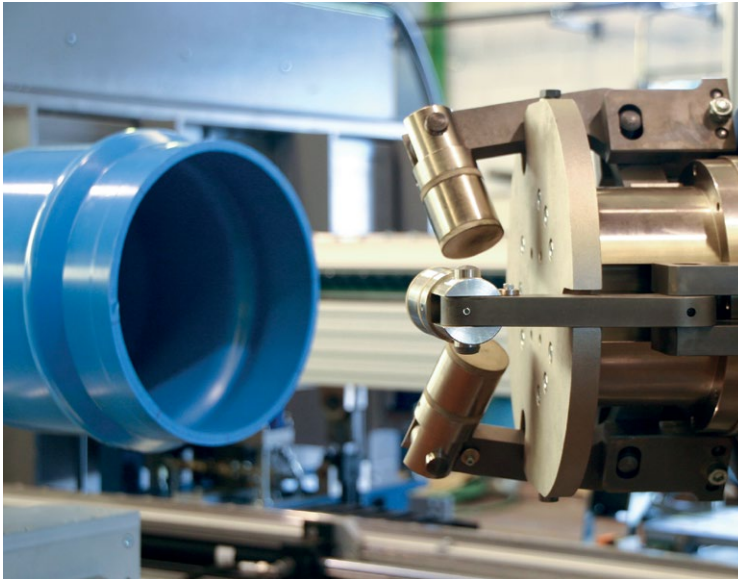

pressed differently, PVC-O pipes keep a total quality of the transported water.

On the other hand, thanks to their physical resistance, TOM® pipes do not require any type of special protection or coating, which means cost-savings. We must focus on their excellent ductility, which allows big deformations of their internal diameter. Furthermore, thanks to this ductility, when crushed, or in the event of a mechanical accident, TOM® pipes immediately go back to its original shape.

Rigid materials for the water conveyance are part of the past. It is the time for plastics, especially for PVC-O, which enables an easier installation and prevents any possibility of water leaks. In addition, one of the most important properties of these pipes is their hydraulic capacity, which means great economic and energy savings.

Together with this attribute, TOM® pipes are characterized by their lightness, including the new DN1200 mm. This characteristic makes of these pipes the ones with the highest installation performance, in fact, they can be manually installed up to DN315 mm.

Molecor, with this new diameter, provides the market with new solutions in order to meet its needs. These pipes can also be installed with ecoFIT TOM® the PVC-O fittings also exclusively developed by the Spanish company. This is a product with which installations become more uniform since pipes and fittings are made of the same material. Molecor is working on enlarging the ecoFIT TOM® PVC-O fittings range, now available from DN110 up to DN400 mm in PN16 bar. Besides this, Molecor also offers other types of products related to transporting water.

This way, with the acquisition of UPA, Molecor offers solutions for water supply building, sewage and drainage through its different brands of products, which are made in 8 manufacturing plants around the world. These products are: TOM®, ecoFIT TOM®, SANECOR, the corrugated system for sewage and drainage, AR®, the soundproof evacuation system,

and EVAC+®, also used within the building sector.

TOM® pipes have the eco-label Environmental Footprint FVS Seal as a proof of the environmental commitment of the firm. This label is promoted by the Sustainable Life Foundation and the General Directorate of Social Responsibility of the Company's Ministry of Employment and Social Security, and it tries to reduce the environmental impact of the European companies disseminating the environmental work carried out by companies.

Referring to useful life, current systems have to be changed or repaired a few years after their installation. Instead of it, TOM® pipes and ecoFIT TOM® fittings have a useful life over 50 years. In other words, these products allow to reduce considerably raw materials and natural resources used in the transport of water.

Moreover, energy consumption of PVC-O pipes and fittings is lower than other traditional materials in all the phases of their life cycle. It is because its inner surface is extremely smooth and, therefore, we need a lower quantity of energy to impulse the canalised fluid.

PVC is a 100% recyclable material, so it can be reprocessed and used in new plastics applications with less technical requirements. Thus, thanks to this plastic material, natural resources can be optimized.

Besides the DN1200 TOM® PVC-O pipe, Molecor will also present other novelty, geoTOM. The company has developed a new application for smartphone and laptops whose objective is to geolocate all the elements of your installation to get real time information at all times, having always present the technical characteristics and traceability of each piece of the project.

During the fair, the Spanish firm will make available to all visitors this application.

► Molecor  
molecor.com/en

K 2022: Hall 16, Stand B17

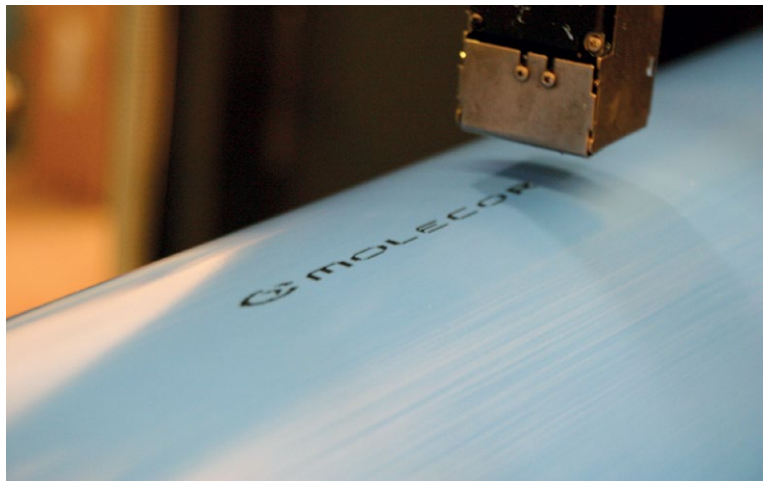

# Recyclable Barrier Systems for Sustainable Packaging

*IKV develops recyclable packaging solutions with the help of plasma technologies*

*With the European Green Deal, the European Commission also approved in March 2020 a new "Circular Economy Action Plan – for achieving a cleaner and more competitive Europe". The aim of this action plan is to encourage the use of sustainable products, business models and services, to adapt consumption patterns with the target of avoiding or reducing waste, and to establish in the EU a well-functioning internal market for high-grade secondary raw materials. Products should then in future, through a circular economy system, be of better quality, more resource-efficient and energy-efficient and, as part of this process, be designed for reuse and repair and for high-quality recycling.*

## Plastics in the action plan for the circular economy

Plastic products, especially in the packaging sector, are at the focus of attention in the transition to recyclable product cycles. The quantity of resources used for packaging and, at the same time, the quantity of plastic waste is constantly increasing and will continue to rise in the coming years without intervention by industry, politics, research and consumers. For this reason, the fundamental requirements made on packaging approved for the EU market are to be made stricter by 2030. The emphasis is being placed on the following aspects:

- Reducing the quantity of packaging and packaging waste by lowering the complexity of packaging – including a reduction in the number of materials used
- Encouraging the reusability and recyclability of packaging through suitable design
- Fixing rules for the safe and reliable recycling of plastics other than PET for use in food contact applications

These areas of focus lead on to technical issues that can be tackled with the help of plasma technologies. The Institute for Plastics Processing at RWTH Aachen University (IKV) has been carrying out research for many years in this field, and is currently developing highly functional coating

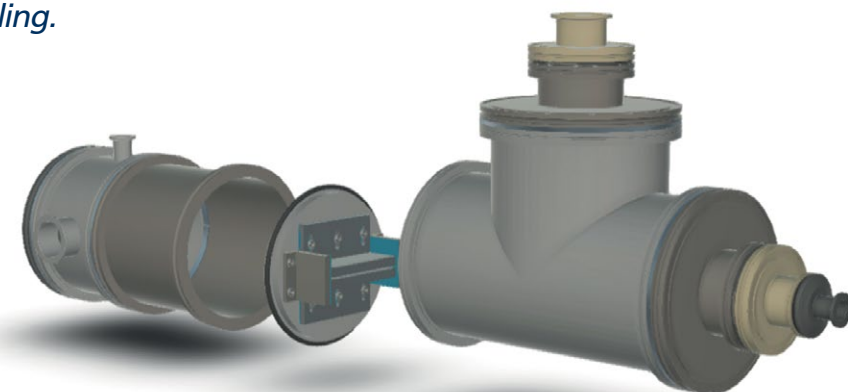

*Picture 1: Experimental setup for the pump design*

systems for various specific fields of application in the field of packaging:

### **Reduction of complex (multi-material) packaging through plasma technology**

Complex multi-layer composites consisting of different plastics that in each case fulfil a necessary packaging function are currently still heavily represented in packaging technology. At the end of their useful life, these composites can be used only for energy recovery because they cannot be segregated into their various constituents. With the help of the Plasma Enhanced Chemical Vapour Deposition (PECVD) technology, plastics can be provided with a high-quality gas barrier that does not impair the recyclability of the plastic. In the discussions on the circular economy, the plasma technology has developed into a highly dynamic area of research with a broad relevance and key innovative force.

The market for flexible packaging is facing major changes because of the challenges that will come about in the transition to the plastic circular economy. Although plastic film is now already being successfully provided with a barrier coat in discontinuous "roll-to-roll" coating processes, there is at present still no continuous process variant that eliminates the non-productive times that are unavoidable in present batch processes and hinder the overall aim of improving the economic efficiency of the process. The target is therefore to overcome this problem with the help of an innovative machine development for continuous PECVD film coating. Here, the film is unwound under ambient pressure and passed through a sluice system into a vacuum chamber, in which a SiO<sub>x</sub> coating is efficiently applied through a so-called "in-plasma concept". Subsequently, the film is again passed through a sluice system at ambient pressure and wound up. Us-

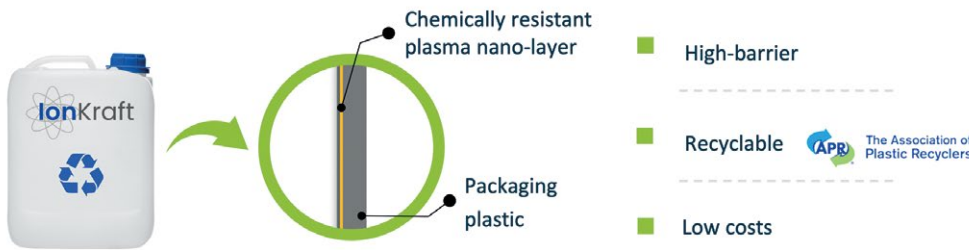

Picture 2: Schematic representation of recyclable barrier packaging for the chemical industry / Picture: IonKraft

ing conventional joining procedures, the process can be carried out without any interruptions. To develop the complex sluice and vacuum systems, the required pump performance is currently being evaluated and a sealing concept is being devised (see picture 1).

**Reusable and recyclable design in the deep tech startup company IonKraft**

The potential and innovative strength of the plasma technology for the circular economy is shown in the founding of the deep tech startup, IonKraft, which has its roots in the Institute for Plastics Processing. IonKraft transfers scientific findings from plasma research to industrial production technology. Based on research and development work carried out in the 1980s at IKV, which has now led to marketable products in the form of interior coatings for PET bottles, IonKraft is focused primarily on developing a systems technology for the coating of large-volume blow-moulded parts. After all, this type of packaging, which is frequently used, for example, in agricultural technology, also needs – for various reasons – to have barrier

properties. Before now, this was only possible with multi-material systems that are unsuitable for recycling. The scaling-up of the process to larger volumes certainly makes fresh demands on the coating machine technology, which have to be met through new constructive modifications in the vacuum technology and also in the microwave technology. Furthermore, the sometimes aggressive agricultural products also make new demands on the PECVD barrier coat, which must also have media-specific resistance properties for this (see picture 2). The business project is being funded by the EXIST research transfer program of the Federal Ministry for Economic Affairs and Energy.

**Use of post-consumer polypropylene for food-contact applications**

The reuse of high-grade recycled plastics in packaging that comes into contact with foodstuffs is – with the exception of PET – not yet properly established. One of the main reasons for this is the authorisation regulations of the European Food Safety Authority (EFSA), which makes strict requirements on the permitted migration of

foreign substances from the packaging into the food. Plasma technology is also an obvious candidate for solving this problem: The good barrier properties that are known to exist against water vapour, oxygen and carbon dioxide should also provide very good resistance to the residual foreign substances from recycle material (see picture 3). The development and testing are being carried out on standard post-consumer recycle (PCR) from the DSD (Duales System Deutschland). In the first step, the contamination of the recycle and its absorption by foodstuffs is simulated with the aid of test substances. In a second step, suitable coating systems are developed that may have to be coordinated to the specific substances. These coating systems are subsequently tested for their suitability for reducing migration. The research work is being supported by the partners Gizeh Verpackungen GmbH & Co. KG and the Green Dot – Duales System Deutschland GmbH. The University of Paderborn is also providing assistance with its expertise in analytics. The approach being pursued can be applied to both rigid and flexible packaging.

The research project described here offers enormous potential for achieving the targets of the European Commission, namely to recycle 55 % of plastic waste by 2030, and thereby substantially increase the proportion of recycle material used in plastic products.

Picture 3: Development of migration barriers for treating post-consumer recyclates

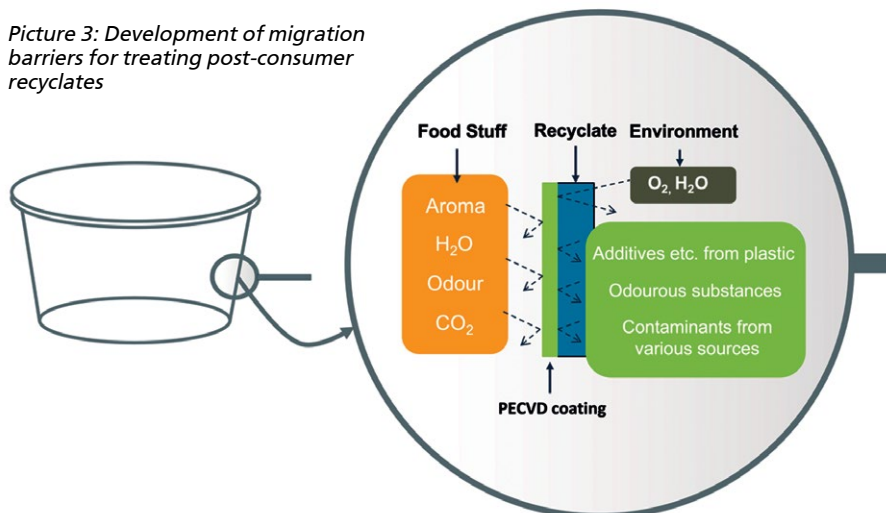

➔ Institute for Plastics Processing at RWTH Aachen University (IKV) Seffenter Weg 201, 52074 Aachen, Germany Prof. Dr. rer. nat. Rainer Dahlmann, Rainer.dahlmann@ikv.rwth-aachen.de



# Closing the Plastic Cycle

## Highly Efficient Filtration for Chemical Recycling of PET

*Plastics can be reused again and again, delivering recycled items of the same quality as new goods – thanks to chemical recycling processes. In the case of PET in particular, new, innovative processes are successfully breaking down used plastics into their chemical components and thus reintroducing them into the material cycle. All these approaches have one thing in common: The purity of the recovered components determines the quality of the end products. A closer look at the processes shows how efficient filtration and cake washing contribute to a technically functional and economically viable solution.*

The Author: Christian Gassen, process engineer at BHS-Sonthofen Process Technology

Plastic waste is one of the key environmental problems of our time. But if suitable recycling processes are applied, used plastic can be turned into a valuable secondary raw material – and this represents a crucial step towards addressing the issues of raw material shortages and high waste volumes. The need for these processes is also reflected in the legal framework: in the EU from 2025 onwards, bottles made of polyethylene terephthalate (PET) must contain at least 25 percent recycled plastic, and by 2030 all packaging on the local market must be reusable and recyclable.

But higher recycling rates also offer considerable economic potential, provided that the plastic industry takes the right steps today. According to the consulting firm McKinsey, reutilization and recycling plastics could lead to increased earnings of up to \$60 billion for the industry. [Cf. McKinsey (2018): How plastics waste recycling could transform the chemical industry.]

### Chemical recycling of PET

Conventional recycling processes have limitations. For mechanical recycling, the plastic is melted and then converted to recyclate, whereby the material's quality suffers. The process reduces the quality of the plastic. Therefore, it is impossible to produce new bottles from 100 percent recycled PET, for instance. Consequently, manufacturers are looking for and evaluating alternative methods. In the meantime, an increasing number of companies are successfully using chemical recycling to achieve a recycling economy.

Chemical recycling is the term used to describe all processes used for the depolymerization of plastics. In more simple terms, plastic objects are first shredded mechanically and then broken down chemically into their basic chemical building blocks, often using a catalyst or enzyme. These have the same properties as raw materials produced from petroleum and are fed directly back into the plastics manufacturing process. The decisive difference to mechanical recycling is that high-quality, ultra-pure materials gained through recycling flow into the plastics production process. The quality of the end products is equal to that of virgin material.

In this way, for the first time, a closed raw materials loop for recycling has been created. Chemical recycling thus opens up new avenues and can at present be regarded as an alternative building block on the way to achieving the targeted recycling quotas. The

*The BHS indexing belt filter is made of stainless steel and supports multi-stage countercurrent washing*

German Federal Environment Agency



*Solid-liquid separation is a particularly important process step in the chemical recycling of PET. Several companies rely on technology from BHS-Sonthofen*

shares this assessment and classifies the chemical recycling of plastics as a preferred process under the Circular Economy Act.

In addition to thermochemical decomposition in the absence of oxygen (pyrolysis) and gasification, recycling technologies that have been discussed and tested in recent years include solvent decomposition, known as solvolysis. Under the action of suitable agents, thermoplastics in particular, such as PET, are liquefied and broken down into their monomers. Since different solvents are used, the solvolysis processes can be broken down into the common methods using glycolysis, methanolysis and hydrolysis (sometimes with enzymatic enhancement). [Cf. The next generation of recycling – giving plastic waste a new life: *Angew. Chem. Int. Ed.* (2020), 59, P. 15402-15423.] All three processes are suitable for degrading PET. The decision of which process is most suitable depends on the quality of the input material.



### High monomer purity

The processes named above produce monomers of the same quality as their petroleum-based counterparts. These are present in the process liquids in a dissolved state and must be separated. In other words, once depolymerization is complete, the monomers are precipitated from the solution and the suspension is fed to a filter. This is where the separation of solvents, catalysts and other components takes place.

The quality of the virgin PET to be produced depends to a large extent on the purity of the monomer, since impurities significantly impair the conversion to polymers and the reactions take a different course. This product purity, which is necessary for a successful recycling process, is mainly achieved by solid-liquid separation with effective cake washing. Several international companies that apply one of the recycling processes described rely on the proven process engineering solutions of BHS-Sonthofen for this step.

### Multi-stage counterflow washing with low resource consumption

BHS-Sonthofen supplied two indexing belt filters of type BF to one of these customers. Both machines operate in parallel in the production line with a throughput rate of 2 t/h. The indexing belt filter of type BF is a continuously operating, horizontal vacuum filter used for the efficient and gentle separation of sedimenting solids from suspensions.

The application involves multi-stage counterflow washing with washing filtrates, which is a highly efficient method of cake washing. In this process, fresh, application-specific washing liquid is used in the final washing zone, which is then reused in the preceding zones. This operating mode is particularly suitable for producing a high level of purity despite low washing liquid and energy consumption.

This is a particularly important feature of cake washing, especially in view of the fact that process efficiency is one of the factors that will determine how chemical plastics re-



*Pressure filtration is also suitable for use in chemical PET recycling*

cyclung develops on the market in the future. And, as an added benefit, the fresh liquid is used to wash the filter cloth before it is used again for filtration and then cake washing. The solid material washed off the cloth is returned to the cycle and reused as a product. This significantly increases the product yield.

BHS-Sonthofen has adapted its filtration process to the requirements of chemical recycling. This means that monomers can be efficiently recovered at high purity levels, allowing it to be used for the synthesis of new PET without requiring any further process steps. Here, the company was also able to draw on its experience from the use of its filters in numerous plastics applications.

### Alternative pressure filtration

Another technology suitable for use in the chemical recycling of PET is the BHS rotary pressure filter of type RPF. This is a continuously operating device for pressure filtration, cake washing and drying of suspensions. BHS-Sonthofen has proven through empirical data and extensive trials that both technologies can be successfully used for the chemical recycling of PET. Customers also benefit from the company's many years of experience in the production of virgin PET.

### Outlook: Product quality and process efficiency are decisive

In summary, chemical plastic recycling offers several advantages: The new processes avoid so-called "thermal recycling," which is nothing more

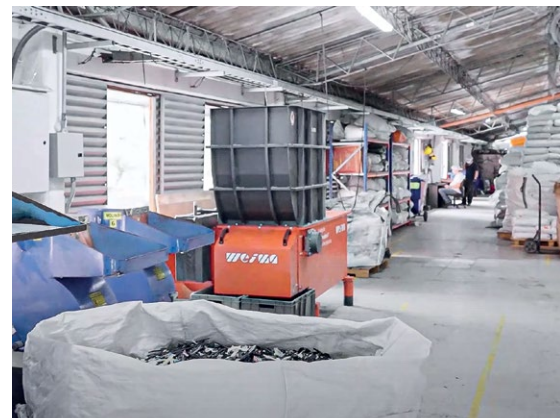

*The BHS rotary pressure filter of type RPF is a continuously operating system for pressure filtration, cake washing and drying of suspensions*

than the incineration of plastics, and they also help to reduce the use of fossil raw materials. Even heavily contaminated plastic waste can be recycled, and waste streams that were previously ineligible for recycling can be used. However, there are challenges of an ecological and economic nature to be overcome. In terms of energy and resource consumption, the processes must be designed in such a way that they have a positive eco-balance and are also viable from an economic perspective.

Therefore, in addition to the quality of the recovered monomers, process efficiency is the most decisive factor when it comes to the industrial use of the processes described.

This calls for new, innovative process solutions that ensure product quality and efficiency in equal measure.

With the use of efficient machines, high yields of monomers are achieved in addition to reduced energy and resource consumption. A tailor-made solution for solid-liquid separation for the respective customer application thus contributes decisively to making the chemical recycling of plastics feasible on a large scale. If technically functional and commercially viable solutions can be established on the market, the industry will have made a decisive breakthrough in the sustainable production of plastics.

➔ **BHS-Sonthofen GmbH**  
**An der Eisenschmelze 47, 87527**  
**Sonthofen, Germany**  
**www.bhs-sonthofen.de**

# Energy-Saving Solution for Pelletizing of rPET/PET

*When it comes to pelletizing of PET, an energy-saving process as well as a certain degree of crystallization is very important. When a customer approached ECON with this request, the technological leader and trusted development partner started to design an underwater pelletizer especially adapted to those requirements. The result is the ECON PET-Edition, which has been optimized for PET/rPET.*

With the help of the ECON patented Thermal Insulation Technology, a safe start-up process is obtained. By preventing heat transfer from the die plate unit into the process water, not only is the freezing of die holes prevented, but a considerable amount of energy is saved. In addition, special attention has been paid to an appropriate insulation of the water tank and the piping in order to achieve an end temperature of the pellets of at least 140°C. Depending on the customer's requirements, ECON provides a tailor-made solution to ensure the required pellet end temperature. Not only the pelletizer is engineered to operate with minimum energy consumption, but the downstream equipment ECS (ECON Crystallization System for PET) as well. This uses the intrinsic heat of the pellets for crystallization and is therefore one of the most efficient methods of crystallizing PET. The system is designed to keep the PET pellets at a constant temperature and to achieve a degree of crystallization of 30 to 40%. In the crystallization channel, the pellets are conveyed further by gentle vibration and mixed to prevent sticking during crystallization. The high degree of crystallization enables a faster pre-drying of the pellets before further processing (e.g. injection molding), which saves a considerable amount of time.

## Low acetaldehyde content

In the food sector, a low acetaldehyde content of recycled PET is required in order to meet the legal guidelines. "Our goal in the development of the ECON PET-Edition was to achieve a significantly improved value in comparison to conven-



tional pelletizing systems," explains Dominik Neumann, team leader of the R&D department. Together with the customer, we worked intensively on an efficient solution. By reducing the pressure build-up at the die plate by 40 %, a lower acetaldehyde content of 30 to 40 % was achieved directly after pelletizing. Previous tests have shown that a lower energy input can be expected during dehydration, since the reduced acetaldehyde content represents a different starting position.

The ECON PET-Edition is a very energy-efficient solution for pelletizing rPET/PET and thus contributes to the circular economy. "When it comes to PET recycling, the kW/t of recycled material has a significant impact on the profitability of the production line. This means that using the ECON

Technology results in a significant competitive advantage", says Gerhard Hemetsberger (Head of Sales). ECON always focuses on a tailor-made solution, based on the individual requirements of their customers.

## K 2022: LIVE Demonstration

At K 2022, the PET-Edition will be displayed in a fully automated version during a live demonstration. Another highlight is the new EWFP (ECON Water Filtration Professional). The filter achieves a grade of filtration up to 55 µm and allows a fully automatic and maintenance-free operation. Besides the running equipment, the pyrolysis furnace EPOS (specially developed for extruder screws) will be exhibited.

→ ECON GmbH

Biergasse 9, 4616 Weißkirchen, Austria

[www.econ.eu](http://www.econ.eu)

K 2022: Hall 9, Stand C30

*ECON PET-Edition  
(fully automated version)*





# EXTRUSION

EXPERT MAGAZINE ON PLASTICS EXTRUSION

The only technical magazine worldwide exclusively for the sectors:

- Material Preparation
- Compounding
- Extrusion
- Recycling
- Calendering
- Thermoforming
- Welding
- Finishing of Plastics and Elastomers



**Extrusion** (German)

**Extrusion International** (English)

**Extrusion International USA** (English)

**Extrusion Russia Edition** (Russian)

**Extrusion Asia Edition** (Mandarin/English)

The only plastics trade magazine for Asia, published from Germany

8 issues a year

6 issues a year

6 issues a year

4 issues a year

2 issues a year

**SMART  
EXTRUSION**

All editions available for free:

[www.smart-extrusion.com](http://www.smart-extrusion.com)

**VM Verlag GmbH** Cologne/Germany





## Web conference

December 8, 2022 • Start: 10.00 CET

[lab.extrusion-info.com](http://lab.extrusion-info.com)

The official language  
of the conference is English

# Laboratory & quality control in plastics processing

- laboratory equipment
- quality control of input raw materials
- quality control of finished products
- analytical equipment
- measuring equipment
- pilot and test lines
- desktop mini IMM and mini extruders
- laboratory mixers and compounders
- laboratory and processing simulation software
- metrology and equipment verification
- laboratory analysis services
- formulation development services
- certification services
- external engineering and research services
- R&D in the enterprise

Developed by:

**VM** VERLAG  
Cologne/Germany

**EXTRUSION**

**EXTRUSION**  
INTERNATIONAL  
WORLDWIDE

**ЭКСТРУЗИЯ**  
EXTRUSION RUSSIAN EDITION

**挤塑** EXTRUSION  
ASIA EDITION

**smart\_molding**  
international



Contact: Alla Kravets • Tel.: +49 2233 949 87 93 • [a.kravets@vm-verlag.com](mailto:a.kravets@vm-verlag.com)