

04/2021

VVA VERLAG
Cologne /Germany

EXTRUSION INTERNATIONAL

USA

THE MELT FILTER SPECIALIST
WE'LL BE CONNECTED WORLD-WIDE

FIMIC[®]
ITALIAN.MELT.FILTER

Groundbreaking Technology
for Plastic Recycling
09/09/2021



Join the
webinar



YOU CAN'T
SCREW UP
WITH ME

www.fimic.it

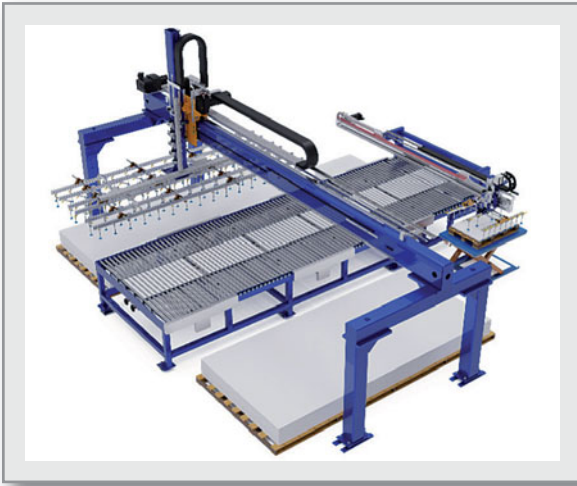
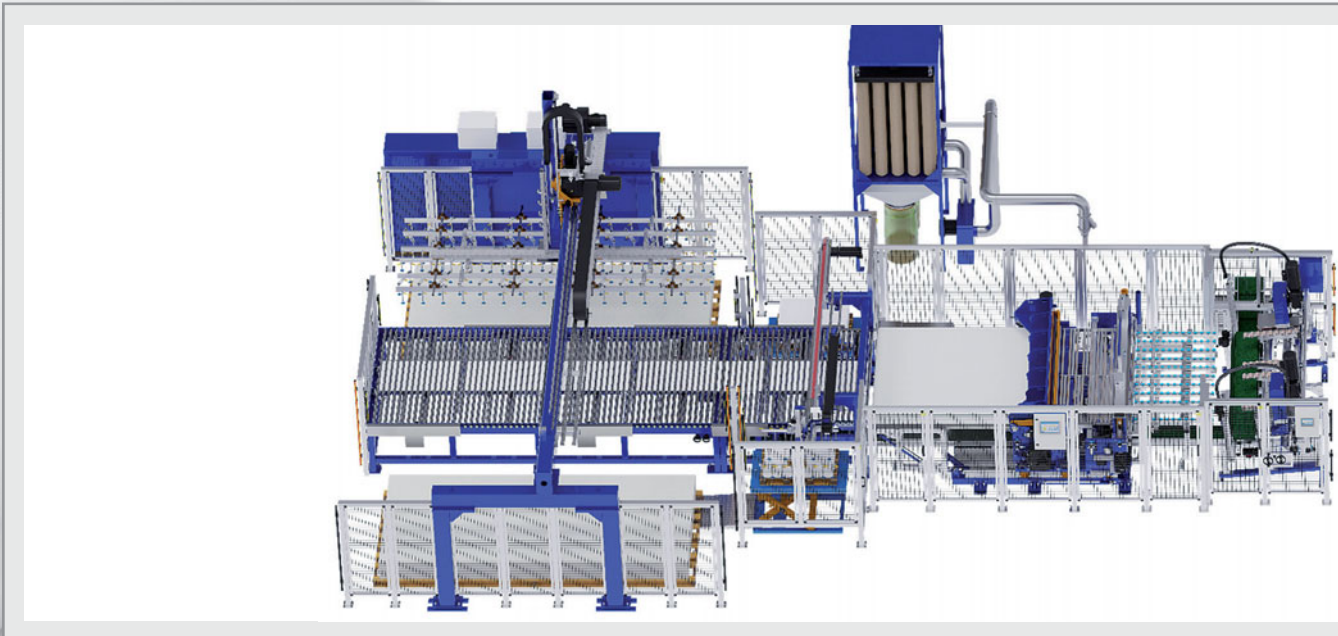

Plate Stacking Machine

for automatic depositing of your production plates on transport pallets or trolleys.

Optional available with:

- Additional stacking places
- Spreading device of sheets side by side
- Separation of consecutive panels for simultaneous stacking



Cross Cutting Combination

enables optional sawing or cutting in one machine.

Optional available with:

- Hydraulic driven scissor
- Electric driven scissor
- Cross Cut Mill instead of saw
- Cutting angle adjustment



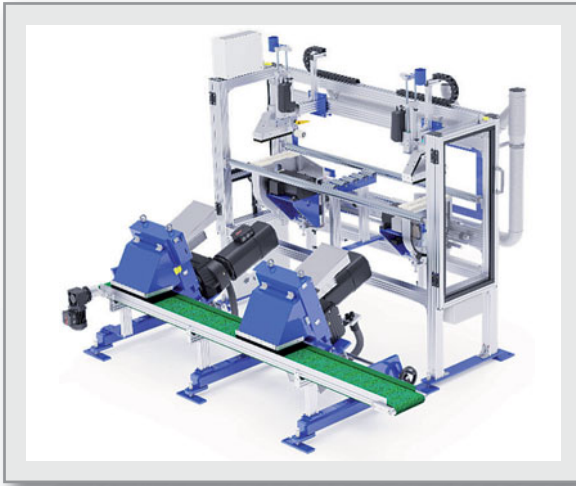

Edge Trimming Saw & Trim Strip Chopper

an unbeatable team for longitudinal cutting of your panel and direct shredding of the resulting return material.

The machines are also offered individually with many options.

As a specialist in the field of special machine construction, we always find a solution!



Pull Off Roller

provides precise regulation and compliance of roller speed and roller force.

Optional available with:

- Automatic material run control
- Selection of roller coatings
- Multiple Pull Off Roller version

Calender

for continuous dimensional accuracy and surface quality.

Key data:

- Throughput capacity depending on material 400 - 1300 kg/h
- Line speed 0,5 - 70 m/min
- Line pressure per roller: 100-1300 N/cm



STEIN Maschinenbau GmbH & Co. KG

Wartbachstrasse 9
66999 Hinterweidenthal/Germany
Tel. (+49) (0)63 96-9215-0
Fax (+49) (0)63 96-9215-25
stein@stein-maschinenbau.de
www.stein-maschinenbau.de

Firms in this issue	6	Recyclability of Multilayer Films Certified	29
Imprint	7	PET Recycling – Decontamination and IV Control in One Step	29
Industry News	8	Making Full Use of Measuring Technology	30
Calendar	8	Additive Guide App	30
The World's Plastics and Rubber Industry focuses on K 2022	8	Product Line Optimized	31
Equiplast 2021	9	Chemical Recycling Europe Joined	31
PLAST Returns in 2023	9	Innovative Process for Bottle-to-Bottle Recycling	32
The PLASTPOL has a new date	9	Partner for Recycling Companies	33
GREENPLAST 2022	10	Acquisition	33
Fakuma 2021 – Characterised by Transformation	10	Industry News USA	34
Anuga FoodTec 2022	11	Sustainable All-Cardboard Blister Pack	34
IPTF 2021 Successfully Completed	12	Two Presentations at the Extrusion 2021 Conference in Rosemont, IL	34
Sustainable Plastics Solutions	13	New Design MEDD Extruder at Plastec West	35
Report: „For which plastic products is biodegradation a viable end-of-life option?“	14	HQ Operations to Expanded Facility in Parsippany, N.J. Moved	35
Successful Course Continues	14	Two Scholarships to Students Specializing in Plastics Awarded	36
Inducted into the „Plastics Hall of Fame“	15	Plastics Machinery Shipments – Typical Slower First Quarter but Poised for Growth	36
New Showroom opened	16	Australian Representative Retained	37
FlexDisc™ is Shortlisted for Plastics Recycling Awards Europe	16	Thermoformer of the Year Named	38
Plastics and Rubber Processing Machines – all indicators good for the first half year	17	New Collaborative Innovation Center	38
Digital Plastic Recycling – Sustainability Award 2021	18	Vice President, Aftermarket Sales Promoted	39
Economic Situation in the European Plastics Industry	18	Commercial Product Director Appointed	39
Operational Turnaround	20	Pipe Extrusion	
Acquisition – Position in Extrusion and Blow Moulding Applications Massively Strengthened	20	Complete Solutions in PVC-O Large Diameter Pipes for a Wide Variety of Applications	40
Changes in Management Board	21	Quality Control	
South African Packaging Manufacturer Acquired	22	Effective Process Optimisation in the Production of LDPE by Means of Online Quality Control	44
Appointment to the European Senate of Business	22	Sheet Extrusion	
Management Succession	22	High Performance and Quality for White Goods	46
Advisory Board Extended	23	Recycling	
Construction Competencies in Blown Film Lines Consolidated	24	Awarded for New Process Technology in Regranulating LDPE / LLDPE Waste Films	48
Investing in Research on Sustainable Packaging Technologies	24	Measuring Technology for Plastics	
Fourteenth Blow Molder Added	25	Affordable and Ready to Start in Virtually no Time – New Downsized Systems	50
Reorganized Management	25	Materials, Natural-Based Specialty Chemicals	
Sustainable Solutions from Plastic and Cardboard Generation Change	26	Alternatives to Castor-Derived Lubricants for PVC Processing	52
Large Die Cart with Crosshead Introduced	26	Extrusion Coating	
„Micro Medical“ Extrusion Tooling	27	Biopolymer Extrusion Coating with „Edge Encapsulation“ Increases Line Speed and Reduces Coat	54
Rotary Extrusion Die with 2X Increase in Speed Latest in a Row	27	Thermoforming	
Counteract Raw Material Prices with Measuring Systems	28	Industry 4.0 Makes Thermoforming More Effective	56
	28		

Front page: FIMIC's newest breakthrough solution for the recycling process

Every once in a while, a revolutionary product comes along and changes everything. FIMIC, the Italian company known as the specialists in automatic self-cleaning melt filters, has been able to introduce a few of this into the world in the last two decades. Since the introduction of the first scrapper technology – a new method of work that didn't just change FIMIC core business, but it changed the whole plastic recycling market – the melt filter specialists developed other solutions to target highly contaminated plastic materials, especially post-industrial and post-consumer plastics. This is how, today, FIMIC is the only company on the market specialized in filtration with a range of five different models of automatic melt filters. This September 9th, in an unprecedented event, broadcasted all over the world, FIMIC will unveil its latest innovation, a technology destined to improve the life and efficiency of recyclers taking it to levels never seen before...The secret is in a screw!



Fimic
www.fimic.it



The need to expand the range in plastic solutions that combine and fully comply with the requirements for the durability of an installation, is what leads Molecor to develop a technological solution for the manufacture of TOM® PVC-O pipes up to diameter 1200 mm **40**

Since 2013, Austrian extrusion and recycling technology company MAS and Dutch film recycling company Caroda have been cooperating in the technological development of film recycling systems. These systems focus on LDPE industrial films, with a higher LLDPE content, as well as agricultural films **48**



The PVC industry depends on a secure supply of additives. To provide more readily available lubricants that are independent of castor as a feedstock but that provide similar performance benefits, Emery Oleochemicals, a global specialty chemicals manufacturer, has developed effective bio-based alternatives **52**

PIXARGUS is notable especially as a supplier of high-end solutions for technologically challenging quality inspection tasks. Now, PIXARGUS is setting a strong foot also in the lower-budget segment **50**

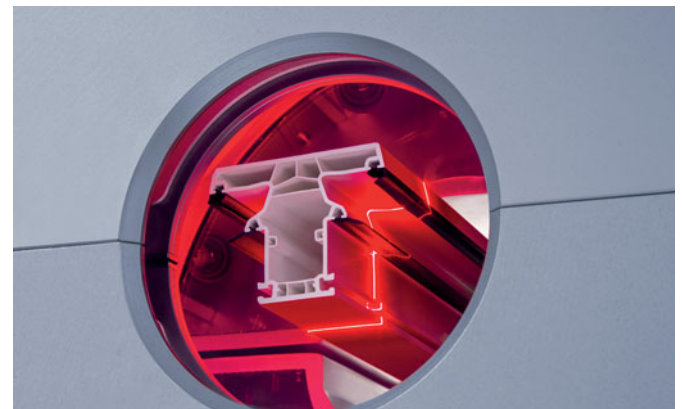

Index of Advertisers, companies and *fairs* referred in this issue

ALPLA	22, 33	MAS	48
Anuga FoodTec 2022	11	Messe Düsseldorf	8
A Più	10, 17	MOLECOR	19, 40
BASF	29	Motan	20
battenfeld-cincinnati	46	motan-colortronic	7
BYK	30	NGR	14
CCA	15	Nordson	16, 55
Clariant	38	nova-Institut	14
Conventus	35	OCS	44
Coperion	25, 32	Pixargus	43, 50
Davis-Standard	25, 35, 39	PlasMec	11
Eagle Manufacturing	25	PLAST 2023	9
Equiplast 2021	9	PLASTICS	36
Emery Oleochemicals	52	Plastics Information Europe	18
EREMA	31	Plastics Machinery Works	37
<i>Fakuma 2021</i>	10, 23	PLASTPOL 2021	9
Feddersen	13	PTI	37
FIMIC	Outside Cover	R-Cycle	18
Gindumac	23	Reifenhäuser	15, 24, 26
Gneuss	29	<i>RePlast 2021</i>	45
GREENPLAST	10	SAM North America	56
Guill	17, 27	Schall, P.E.	10, 23
ILLIG	20, 26, 34, 56	Sikora	28, 30
iNOEX	34	Smart-Extrusion	Inside Back Cover
<i>IPTF 2021</i>	12	SPE Thermoforming	36, 38
Kautex	22	Stein Maschinenbau	Inside Front Cover+3
Kiefel	24	Troester	28
Koelnmesse	11	Vecoplan	33
KraussMaffei	21	Vetaphone	16
<i>Laboratory & Quality Control</i>	<i>Outside Back Cover</i>	VM Verlag	45
Maag	22, 41	Zumbach	13
Maguire	31		

Follow the news in the world of extrusion!

Subscribe to digital magazines
and Smart Extrusion weekly newsletter

- **Just** submit your **e-mail address**.
- Digital magazines and news updates **free of charge**
- No spam. Your data is safe



www.extrusion-info.com/subscription



The Extrusion International Magazine is published bimonthly by VM Verlag GmbH. P.O.Box 501812, D- 50879 Cologne, Germany

EDITORS

Bettina Jopp-Witt (Editor-in-chief)
Tel. +49 221 546 1539
redaktion@vm-verlag.com

Dmitry Kosuch
Tel. +7 996 730 0113
d.kosuch@vm-verlag.com

ADVERTISING SALES

Martina Lerner
Tel.+49 6226 971515
lerner-media@t-online.de

Bella Eidlin
Tel. +49 152 29907895
b.eidlin@vm-verlag.com

Olga Kirchner
Tel. +49 152 05626122
o.kirchner@vm-verlag.com

ADMINISTRATION

Alla Kravets
Tel. +49 2233 949 8793
a.kravets@vm-verlag.com

PRINTING

maincontor GmbH
Dr.-Gammert-Str. 13a, 63906 Erlenbach, Germany
T.: +49 937294810811
www.maincontor.de, info@frankhohmann.com

SALES REPRESENTATIVES

Quaini Pubblicita (Milano IT)
Tel. +39 02 39216180
info@quaini-pubblicita.it

China & Asia
octavia@ringier.com.hk, Tel. +852-9648-2561
maggieliu@ringiertrade.com, Tel. +86-13602785446

Tokyo PR Inc. (Japan)
Tel. +81 (3) 3273-2731
extrusion@tokyopr.co.jp

Reprints, Translation etc

No part of this publication may be reproduced, stored in a retrieval system, or transmitted, in any form or by any means, electronic, mechanical, photographic, recording or otherwise, without prior permission of the publisher.



www.smart-extrusion.com

motan® 
colortronic®

The smart way to dose pellets

Fakuma  **Please visit us:
Hall B1,
Stand B1-1111**

 **think materials management**

GRAVICOLOR

With IntelliBlend and integrated conveying.

motan-colortronic gmbh - info@motan-colortronic.de
www.motan-colortronic.com



Equiplast

14. - 18. 09. 2021
Barcelona, Spain
www.equiplast.com/en

Plastpol

21. - 23. 09. 2021
Kielce, Poland
www.plastpol.com

interplas

28. - 30. 09. 2021
Birmingham, United Kingdom
www.interplasuk.com

Fakuma

12. - 16. 10. 2021
Friedrichshafen, Germany
www.fakuma-messe.de

Central Asia Plast World

11. - 13. 10. 2021
Almaty, Kazakhstan
www.plastworld.kz

ARABPLAST 2021

15. - 18. 11. 2021
Dubai, UAE
www.k-globalgate.com/arabplast

Solids Dortmund

16. - 17. 02. 2022
Dortmund, Germany
www.solids-dortmund.de

PLASTINDIA

17. - 21. 02. 2022
New Delhi, India
www.k-globalgate.com/plastindia

ICE Europe

15. - 17. 03. 2022
Munich, Germany
www.ice-x.com/europe

CHINAPLAS 2022

25. - 28. 04. 2022
Shanghai, P.R. China
www.ChinaplasOnline.com

The World's Plastics and Rubber Industry focuses on K 2022

■ Now the deadline for registrations for K 2022 has been reached, it is clear that the interest taken by exhibitors in the world's most important trade fair for the plastics and rubber industry, to be held in Düsseldorf from 19 to 26 October 2022, continues unabated. "K 2022 will again occupy the entire fairgrounds," rejoices Erhard Wienkamp, Managing Director at Messe Düsseldorf, and goes on to say: "When talking to exhibitors we feel that there is an enormous demand for personal exchange on a global level."

K 2022 will again welcome the "Who's Who" of the international plastics and rubber industry to Düsseldorf – there is no other place with such high international attendance. Some 3,000 companies from all continents have registered to exhibit their innovations in the segments: Raw materials and auxiliaries; Semi-finished products, technical components and reinforced plastic products; Machinery and equipment for the plastics and rubber industry.

K provides the global plastics and rubber industries with their most important information and business platform. Exhibitors and visitors from all over the world get together here and use the opportunities their No. 1 trade fair offers to demonstrate the operational excellence of this industry, discuss current trends and chart the course for the future. K 2022 comes precisely at the right time to offer the plastics and rubber industry orientation again after the changes induced by the pandemic.

K not only serves as the arena for forward-looking product innovations every three years but also underlines its exceptional positioning by addressing both the challenges of our day and age and of its industry, in particular. This is reflected above all by the three major guiding themes of K 2022:

- Circular Economy
- Digitalisation
- Climate Protection

These leading themes will be echoed by both the exhibitors' presentations and in the focus of the official special show *Plastics Shape the Future*, the *Science Campus* and *VDMA's Circular Economy Forum*.

The winning formula at K in Düsseldorf also means always being oriented towards market needs and developing its concept further. This is why the physical event on site will be extended to include additional digital content.



► Messe Düsseldorf GmbH
www.k-online.de

Equiplast 2021



■ Leading companies from three sectors that have proved to be essential during the pandemic will meet at another Expoquimia, Equiplast and Eurorufas event to display the innovations in their products and processes that they've developed with the aim of contributing to sustainable development. Organised by Fira de Barcelona, the fairs will take place in person from 14th to 17th September at the Gran Via venue with the participation of more than 350 exhibitors representing around 600 brands.

With more than 200 brands, the 19th Equiplast, the International Plastics and Rubber Event, will showcase the solutions developed by the sector to promote the circular economy with the aim of minimising its environmental impact. In this regard, for the first time Equiplast will recreate a recycling plant to scale

called Reciplast to demonstrate how there are currently reliable systems for the recovery of plastics. It will also feature Rethinking Plastics, a unique exhibition of products made from 100% recycled plastic from renewable and biodegradable sources.

Equiplast president Bernd Roegele believes that "recycling and the circular economy are demonstrating the opportunities and the path towards sustainability of a material such as plastic, which is really important in basic sectors for society such as health, industry and technology".

In order to guarantee the safety of the suppliers, exhibitors and visitors, these fairs will apply the COVID-19 prevention and safety protocol developed by Fira de Barcelona following the advice of the Hospital Clínic de Barcelona.

► Equiplast
www.equiplast.com/en/
 Edu Pérez Moya
eperezm@firabarcelona.com

PLAST Returns in 2023

■ The organization team for PLAST-International Exhibition for the Plastics and Rubber Industries announced the upcoming edition of the fair, 5-8 September 2023 at the Fiera Milano fairgrounds in Rho-Pero.

Exhibitors originally enlisted in PLAST 2021 have already moved to ensure a place at PLAST 2023, confirming 30,000 m² of exhibition space. Applications for new exhibitors will officially open in June 2022.

The previous edition of PLAST, which took place in 2018, recorded over 1,500 exhibitors in a net space of 55,000 m² and drew in more than 63,000 visitors, with a significant increase in visitors from other countries, reaffirming the international appeal of the specialized fair in Milan. In keeping with tradition, PLAST offered operators a broad and varied technology showcase, especially as regards the core of the exhibition, i.e., the machinery,

auxiliaries, and moulds for plastics and rubber processing. More than 3,500

different equipment were exhibited in six exhibition halls. This sector represents a major slice of Italian manufacturing, with a production value estimated by the trade association AMAPLAST at 3.74 billion euros in 2020, with exports accounting for some 70% of production.

In keeping with previous editions, the content of PLAST 2023 will not be limited to machinery but range from innovative materials to cutting-edge production processes, and from high-tech finished products to personalized services. As usual, a rich programme of seminars, workshops, press conferences, and company presentations will ensure a wealth of opportunities for professionals in the sector to meet and exchange ideas with other operators.

► plastonline.org



The PLASTPOL has a new date

■ The Targi Kielce's International Fair of Plastics and Rubber Processing PLASTPOL is held from 21 to 23 September 2021. Modern processing and converting machines and technological solutions came in abundance at the expo.

PLASTPOL is complemented with a plethora of knowledge-sharing conferences combined with discussion panels and seminars. The ubiquitous automation and digitisation of industrial production throughout the whole process, ranging from components through finished goods, is a trend that has dominated at PLASTPOL for years. A whole array of expo stands are the traditional display for the latest robots, machines, moulding machines, extruding presses, entirely computerised and automated production lines that interact with each other.

The global epidemiological situation has significantly improved recently; this is owed to the global vaccination campaign against Covid-19. The intended effects are now visible. Therefore, open borders and travel possibilities become very likely. Business meetings and trips are also on the horizon, which is an essential element that influences the success of the international event.

The PLASTPOL exhibition held in 2020, although much smaller, fulfilled its main role of an effective and efficient marketing tool; Targi Kielce has been informed about the successful sales of machines.

PLASTPOL 2019 was a record-breaking event in terms of the number of foreign exhibitors. The all-time top show was marked by 910 companies from 42 countries, the exhibition area of 17,500 square meters and the seven exhibition halls filled to the brim.

► www.plastpol.com

GREENPLAST 2022

■ Promaplast presents GREENPLAST, a new exhibition/convention dedicated to materials, technologies, and converting processes for plastics and rubber, with a strong emphasis on environmental sustainability, recovery and recycling of materials, and energy efficiency.

From the 3rd to the 6th of May 2022, Fiera Milano will host the entire plastics and rubber industry in an event dedicated to innovative solutions to boost environmental sustainability, energy efficiency, options for Reducing-Reusing-Recycling, and progress towards a circular economy.

The leading Italian and international companies will have the chance to show their innovative solutions for environmental sustainability in the halls of the fairgrounds:

- virgin, low-impact, low-carbon-footprint raw materials, secondary raw materials, biopolymers, additives
- semi-finished and finished products made from innovative, recycled, or biologically sourced materials
- machinery, equipment, and systems that combine low energy consumption with high performance, high-efficiency

processing and are able to use innovative, recycled and/or biologically sourced materials

- systems and machinery for the selection, processing, and recycling of plastics and rubber, both in-line and post-consumption
- support and consulting services for plastics and rubber production generally and recovery and recycling
- public corporations, consortia, and organizations active in plastics and rubber recycling.

Additionally GREENPLAST will feature an international conference, hosting world renowned speakers who will discuss key issues relating to the trade fair: environmental sustainability and the circular economy, especially as they relate to packaging and plastic products.

The event will be held in parallel with IPACK-IMA, international exhibition for the packaging industry.

The dialogue with and among the plastics industry will gain new impetus in 2023 with the triennial international fair PLAST, which has finally been rescheduled for 5-8 September 2023. Exhibitors have already confirmed 30,000 m².

► A Più Srl
greenplast.org

Fakuma 2021 – Characterised by Transformation

■ Exhibitors and expert visitors are eagerly awaiting the 27th Fakuma international trade fair in Friedrichshafen from the 12th through the 16th of October, 2021. In addition to ongoing developments in the digital transformation of the plastics processing industry, this exceptional event will also focus on the changeover from a linear to a circular economy.

“The exhibitors want to finally present their innovations live once again,” says Bettina Schall, managing director of P.E. Schall GmbH & Co. KG. “That’s why users and customers are looking forward to the physical presentation of new products and technological solutions.” As a widely recognised leading technical event in the fields of injection moulding, extrusion technology, thermoforming and 3D printing, Fakuma will demonstrate that a great deal has been achieved in terms of machine and product development, as well as process improvements.

German plastics processors are facing a variety of challenges resulting from changes taking place at various levels: increas-

ing digitalisation and automation are providing opportunities for improving processes, as well as for increasing systems availability, efficiency and productivity. At the same time, the sector is intensively engaged in the transformation from a linear to a circular economy. Companies in the plastics industry are highly committed to assuming responsibility for their products, as well as for products manufactured on their machines and systems. And thus working on one’s own future is also accompanied by a commitment to the future viability of generations yet to come. Plastics recycling and the circular economy are key topics all over the world, both in the industry itself and amongst users and the general public. “The plastics industry – plastics manufacturers and processors, manufacturers of plastics processing machines and users alike – have never had to deal with forward-looking issues and sustainable solutions as urgently as they do at the moment,” notes Bettina Schall.

“Our booking status is extremely satisfying”, announces Fakuma project manager Annemarie Schur. “Everyone’s getting ready to discuss things with each other face to face and exchange ideas in person. We’re taking care of everything necessary in terms of organisation and implementation.”

► P. E. Schall GmbH & Co. KG
www.Fakuma-Messe.de
www.fakuma-messe.de/fakuma-virtuell/



Anuga FoodTec 2022

■ Anuga FoodTec, the International Suppliers Fair for the Food and Beverage Industry is also recording an excellent number of registrations for the new venue date from 26. - 29. 04. 2022. As the most important international industry event after the Corona pandemic, Anuga FoodTec offers the food and beverage industry an ideal information and ordering platform for all sections of the production, processing and packaging. This year's trade fair concept is designed as a "special edition", namely by linking up the compact physical trade fair with the high-reach digital platform AnugaFoodTec @home. Anuga FoodTec has already convinced numerous market leaders, medium-sized and smaller companies for the 2022 event with this concept.

Due to the digital platform AnugaFoodTec @home being staged parallel to the physical trade fair, the exhibitors will benefit from an effective, digital expansion of their trade fair presence. The innovative format offers networking and contact options primarily also with those visitors and interested parties, who will still not be able to travel to the extent desired in the coming year.



■ Koelnmesse GmbH
www.anugafoodtec.de



For over **50 years** a landmark in the international market for the **manufacturing of complete mixing plants**

**PVC DRY BLEND - POWDER COATINGS
 MASTERBATCH AND PIGMENTS - THERMOPLASTIC RUBBER
 WOOD PLASTIC COMPOSITES**

PLAS MEC S.R.L.
 Via Europa, 79 - 21015 Lonate Pozzolo (VA) ITALY
 Tel: +39 0331 301648 - E-mail: comm@plasmec.it
www.plasmec.it

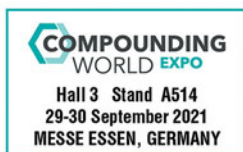

IPTF 2021 Successfully Completed

■ On 25 and 26 May, the 9th International Polymer Technology Forum (IPTF) was held in St. Petersburg, as in previous years. The organisers – the trade magazine Extrusion (VM Verlag) and Plastics – were able to bring together 302 experts from the polymer industry from all regions of Russia, neighbouring countries, the USA and Europe. More than half of the participants represented the extrusion sector.

This is the first time that the Forum has attracted such a large number of participants. This is possibly due to the revival of business after the lockdown, but also, as some visitors pointed out, to the well-designed format of the Forum. The event covered a wide range of issues related to plastics processing and gave specialists in the field the opportunity to discuss important topics, exchange information, conduct negotiations and make new contacts.

The general sponsor of the IPTF 2021 was the company SIBUR. Information technology support was provided by Interplastic. Within two days, a total of 40 presentations were given on various topics during the plenary session and at the individual stations. Issues were addressed such as trends in Russian plastics production, state of the Russian raw material base, implementation of such technologies as injection and blowmoulding, extrusion, compounding and thermoforming, modern ecological requirements and recycling technologies, novelties of laboratory equipment, methods of quality control, etc.

Speakers included representatives of renowned companies such as: SIBUR, JSW, Brabender, Kautex, KraussMaffei, Graham Engineering, Jwell, Reifenhäuser, Aleko, FIMIC, Herbold, EREMA, OCS, etc.

Among the visitors were representatives from very different sectors of the polymer industry: from injection moulding and toolmaking, thermoforming, production of nonwovens and geosynthetics, suppliers of equipment and raw materials, etc. More than half of the audience came from film and sheet extrusion, pipe and profile extrusion, blowmoulding, full-



mouldcasting and masterbatch production, flexible and rigid packaging production and converting. Thus, the station on extrusion technology was also always well attended.

In addition to the lectures, there was plenty of space in the conference room for exhibitors to present themselves and advise interested listeners. Some speakers brought their products and technological equipment from the exhibition to present in the lecture.

The extensive theoretical programme was supplemented by practical event parts. For example, on 27 May the participants were able to visit companies in the plastics manufacturing industry in St. Petersburg. The participants had the opportunity to visit a multidisciplinary, innovative production facility of the company StarLine and to visit the Komsomolskaja pravda plastics factory.

An evening river cruise through the canals of St. Petersburg with a magnificent view of the city rounded off the programme.

Spectators as well as speakers and exhibitors unanimously expressed their positive impression of the Forum, both in terms of organisation and content. Many participants already said they would like to attend the IPTF again in 2022.

The next IPTF 2022 is planned for 18 to 20 May, again in St. Petersburg.

Sustainable Plastics Solutions

■ Since 2014, the Hamburg-based plastics distributor K.D. Feddersen has been cooperating with Aurora Kunststoffe GmbH, a manufacturer of high-quality engineering recomponds based in Neuenstein/Baden-Württemberg. Now the two companies have deepened their cooperation in this area, and the sales region has also been expanded to include the distributor's European subsidiaries.

K.D. Feddersen is thus strengthening its wide range on engineering plastics and high-quality recomponds in order to meet the high demand for recycled or sustainable materials and to contribute to the circular economy.

The portfolio includes numerous engineering polymers such as PA 6.6, PA 6, ABS, PC+ABS, PC, POM, PPS, PBT and many more. Depending on the product, these are available unfilled and/or modified with a filler system. Customised solutions can also be realised together with the manufacturer. Numerous Aurora re-

compounds are already established with well-known OEMs and meet the strict requirements for series production.

"Our customers benefit from recycled as well as environmentally friendly plastics with a high-quality property level and low CO₂ footprint," says Hermann Legatzki, Head of Product Management at K. D. Feddersen. "By using recomponds, 8.64 kg of CO₂ can be saved in relation to a 1 kg material, using the example of a PA 6.6 with impact modification."

■ K.D. Feddersen GmbH & Co. KG
www.kdfeddersen.com

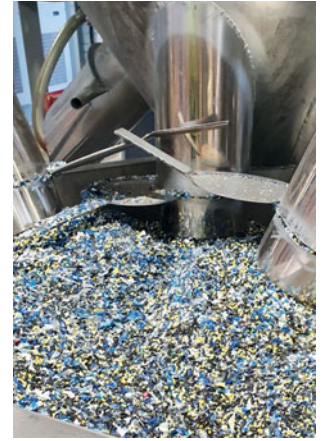

The recycling of plastics helps to significantly reduce waste (Picture: Aurora Kunststoffe GmbH)

Precision Wall Thickness Measurement

Zumbach
 SWISS PRIME MEASURING SINCE 1957

RAYEX S XT

- Easy and quick set up for new products
- Fast eccentricity and diameter measurement
- Added longevity due to high-quality xray source



Family owned since 1957, Zumbach is a global leader in the industry. Driven by innovation and experience. We are here for you and ready to build the future together.

www.zumbach.com • sales@zumbach.ch

Report: „For which plastic products is biodegradation a viable end- of-life option?“



■ The BioSinn project found products and applications for which biodegradation at the end-of-life is a real option. 25 fact sheets answer technical and regulatory questions for each application. The market volume of these applications was also estimated: in Germany, it is about 170,000 tonnes, in the European Union about 1 million tonnes per year.

In the EU, several million tonnes of plastics end up in the environment. In nature, in water, in the compost stream – every year, unhindered. Once there, it is often almost impossible to return them to the recycling stream: too small, untraceable, too costly. But there are plastic products that, even when used correctly, don't even make it into the recycling stream and end up in nature, in water or in the compost. And we deal with many of them every day.

Would the use of biodegradable materials made from renewable feedstocks be a sensible option here? Critics doubt that biodegradation is of any benefit at all and rely on comprehensive reduction, collection and recycling of plastic products. They also fear that biodegradable products could induce consumers to dispose of the products in the environment.

In the project “BioSinn – Products for which biodegradation makes sense”, that was funded by the Federal Ministry of Food and Agriculture, experts from the nova-Institute in Hürth near Cologne investigated whether there are applications and products for which biodegradation is a sensible or even the best end-of-life option. The selection criteria were that collecting the products (or their remaining parts), separating them from other organic waste or material recycling is not possible, eco-

nomically not feasible or does not take place in practice. Further criteria were that the input of microplastics into the environment can be avoided through the use of biodegradable materials or that indirect positive effects, a relevant secondary benefit, can be achieved through the use of biodegradable materials.

Experts from the nova-Institute, together with the project partner Institut für Kunststofftechnik at the University of Stuttgart (IKT Stuttgart) and a project advisory board made up of representatives from industry, academia and politics, were able to identify 25 applications on this basis for which biodegradability is a good or even the best end-of-life option. These were examined from all sides: in which environments exactly do the products remain? Are there already suitable biodegradable materials made from renewable raw materials for these specific requirements? How are current market or political framework conditions?

In addition to the products used by end consumers, more unknown or inconspicuous applications have also been uncovered that cause a large plastic input into the environment.

The result of the project is a brochure for decision-makers from industry and politics but also for the general public, with 25 fact sheets and extensive background information on biodegradation.

The final report is provided in both German and English. The full report is available in both languages here:

► www.renewable-carbon.eu/publications/nova-Institut GmbH

Successful Course Continues

■ With the new business year, Erich Fuerst has taken over responsibility for the operational areas of the Next Generation Recyclingmaschinen (NGR) as COO from his long-time predecessor and company co-founder Gerold Barth. The plastics recycling machine manufacturer can look back on a successful business year and has now also been awarded the most important business prize of the province of Upper Austria.

Erich Fuerst is new COO of Next Generation Recycling Machines



Pegasus 2021 in gold for NGRs innovative power (Photo: NGR)

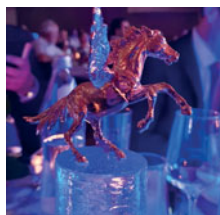

Erich Fuerst has been responsible for the operational areas of purchasing, production, logistics and quality assurance for the past year as operations manager of the Feldkirchen site. Gerold Barth, the company co-founder, who in the past 25 years has taken NGR from a small startup company and developed it into one of the leading companies in its sector, will now focus his efforts on the broader development of the Next Generation Holding.

Together with his fellow managing directors Wolfgang Steinwender, CEO, and Thomas Pichler, Joint Partner and CTO, Erich Fürst recently received the „Pegasus 2021“ award. This business prize is awarded to the most innovative and successful companies in Austria. Out of more than 200 nominations, NGR achieved 1st place in the Innovation category and was thus rewarded not only for the high degree of innovation, but also for the general business success, the strong growth especially during the challenging times of the protracted pandemic, and for achieving certain CO₂ reduction measures.

► [Next Generation Recyclingmaschinen GmbH \(NGR\) www.ngr-world.com](http://www.ngr-world.com)

Inducted into the "Plastics Hall of Fame"

■ Ten leading personalities from the international plastics industry were recently inducted into the "Plastics Hall of Fame" – one of them is Ulrich Reifenhäuser, CSO of the Reifenhäuser Group, Chairman of the Exhibitors' Advisory Board of the "K" plastics show and Chairman of the Plastics and Rubber Machinery Association in the VDMA.

The Plastics Industry Association (PLASTICS) founded the Hall of Fame 1972 to recognize the industry leaders who have made a special contribution to the success of the plastics industry worldwide through their activities. Nomination takes place every three years and the winners are usually announced at the NPE, America's largest plastics show.

"It is with great delight and pride that I accept the honor of becoming a member of the Plastics Hall of Fame," says Ulrich Reifenhäuser. "It comes at a turning point in our industry that is undergoing possibly one of the most exciting phases since the invention of plastic. Whereas the focus in the past was on material performance and costs, the dominant topics now are on recyclability and a holistic circular economy. We will harness this change as an opportunity. With its low weight, high functionality and recyclability, plastic has all the characteristics to make a decisive contribution to climate neutrality."

Ulrich Reifenhäuser was predestined for a career in plastics. As the son of Hans Reifenhäuser, who was also posthumously inducted into the Plastics Hall of Fame in 2014, he now runs the family business in the third generation together with his brother Bernd Reifenhäuser (CEO). He first started working in the extruder construction department of his father's company at the age of 16. After studying economics and holding various positions, he joined the executive management of the Reifenhäuser Group in 1992. Since that time, he has been responsible as Chief Sales Officer (CSO) for international line sales and has built up an international network of customers and partners second to none. In 2022, he will be jointly responsible for the world's leading plastics show in Düsseldorf as "Chairman of K show" for the seventh time in a row.



Ulrich Reifenhäuser (CSO, Reifenhäuser Group) is now a member of the "Plastics Hall of Fame" (Photo: Reifenhäuser)

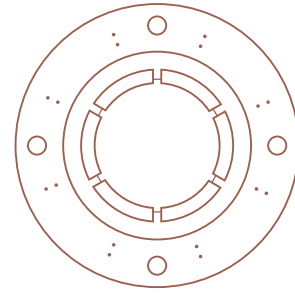

CCA
The Original

Innovation is our Passion

CCA offers different adjustable calibration sleeves to optimize your plastic pipe production – from 14 up to 2,600 mm pipe outside diameter.

Discover now the individual solution for your needs:

- conventional
- 2-point adjustment
- 1-point adjustment
- 4-point adjustment



New Showroom opened

■ Vetaphone has opened a new high-tech showroom and demonstration facility at its headquarters in Kolding, Denmark. Designed to showcase the company's extensive range of corona technology, the exhibits, which include treatment units for applications as diverse as extrusion, high-speed printing, converting, and narrow web, can all be demonstrated in action, giving the company an unmatched opportunity to discuss customers' specific requirements so that the system supplied is a perfect fit for their production environment.

Announcing the opening of the showroom, CEO Frank Eisby stated: "We are immensely proud to be the inventors of the corona process and of the pioneering work we have done in surface treatment over the past seven decades. The new showroom is another important link in our strategic programme of education and excellence and will provide a unique opportunity for customers to see at first hand exactly what our state-of-the-art technology has to offer."

The timing of the new showroom is significant as it fits perfectly with the change of business processes brought about by the global pandemic. With the short-term demise of trade shows, and an increased awareness of what online communication technology has to offer, customers now have the opportunity to combine personal visits to the showroom with online meetings and build a technical and commercial partnership with Vetaphone that will ensure the long-term success of their business. Vetaphone CSO Jan Eisby takes up the story: "Even before the recent travel restrictions were imposed the nature of capital



The new showroom and demo facility in Kolding is fully equipped with the latest surface treatment technology for online and in-person visits

equipment sales had changed. Online research allows customers to be so much better informed these days prior to making an investment in technology. Vetaphone has always believed in the importance of face-to-face contact and the ability it gives us to share knowledge. But we know that many of our existing and potential customers are unable to visit us in Kolding. Now, using digital communications we can take our showroom to customers wherever they are in the world and demonstrate our technology to them as though they were here in Denmark."

The new showroom completes a three-phase building plan to boost the Vetaphone brand in the global market that began with the opening of a new high-tech HQ back in 2017 and was followed by the very successful launch of its Test Lab facility last year. Along with the expansion of its global sales and service network, which now covers more than 60 countries across all continents, Vetaphone is well on-track to meet its ambitious plans for the future.

► Vetaphone
www.vetaphone.com

FlexDisc™ is Shortlisted for Plastics Recycling Awards Europe

■ The BKG® FlexDisc™, an innovation by Nordson Corporation that significantly enhances melt filtration in the recycling of post-consumer PET, has been selected to be a finalist in the Plastics Recycling Awards Europe competition. The category in which it is shortlisted is "Recycling Machinery Innovation of the Year."

Two to four FlexDiscs can be combined in a filter stack, providing filtration area far greater than is available with standard flat screens without increasing machine size or weight. It yields finer filtration, prolongs filter life, and reduces backflush volume.

Recommended for Bottle-2-Bottle recycling and rPET fiber production, the FlexDisc is designed for use with piston-driven backflush screen changers, such as Nordson's HiCon™ V-Type 3G sys-



BKG® FlexDisc™

tem. Nordson has named the combination V3G + FlexDisc = rPET Power².

"In view of today's urgent need to expand post-consumer recycling, Nordson is especially honored to be shortlisted in the Plastics Recycling Awards Europe competition," said Oliver Brandt, Market Development Manager, Recycling. "Our BKG FlexDisc has been shown to enhance the productivity of PET recycling while saving costs and improving the quality of the finished product."

The Plastics Recycling Awards Europe 2021 winners will be announced on 5 November, during the second day of the Plastics Recycling Show Europe taking place at the RAI Amsterdam.

Open to organisations and individuals across Europe who are involved in the recycling of plastic materials, the Plastics Recycling Awards Europe are organised jointly by Plastics Recyclers Europe (PRE) and Crain Communications, organisers of the Plastics Recycling Show Europe.

► www.prseventurope.com/prse2021/en/page/awards2021

Nordson Polymer Processing Systems
www.nordsonpolymerprocessing.com

Plastics and Rubber Processing Machines – all indicators good for the first half year

■ A positive trend for plastics and rubber processing machinery in the first half of 2021 announced by the trade association AMAPLAST: the latest mid-year survey conducted by the MECS Statistical Study Center records double-digit growth in both turnover and orders, consolidating the climate of renewed faith in the sector after the long and difficult period of the pandemic. With respect to January to June 2020, turnover has increased by +11%. Domestic machines sales have remained high while demand abroad principally regards replacement parts.

Companies have also witnessed a clear improvement in their order books in the first six months of 2021, recording +46% with respect to the previous year. The recovery is mainly driven by the major commissions for plants by Italian customers (with an impressive +134% in the last quarter alone) but there is also a very positive trend in orders from abroad, both for machinery and for replacement parts (+58%). Given this trend an average of 6.4 months of production are already assured.

The rebound in the domestic market thus confirms a greater propensity for investment by Italian companies, partially thanks to incentives (tax credits for modernizing systems and investing in Industry 4.0) provided by industrial policy plans.

All four major sectors for plastics and rubber processing machines continue to show lively performance. Medical, packaging, and automotive in particular show signs of growth that should be confirmed in the coming months while the construction industry has stabilized.

Uncertainties still remain regarding the spread of the Delta variant and concern is still high about high raw materials prices and their relative scarcity, factors which lengthen average delivery times and compress margins.

Also contributing to tensions is the unabated rise in sea freight rates, which have reached record levels. Logistic difficulties and increasing shipping prices are seen in all geographical areas and the trend may continue through the summer, since demand generally increases in this season.

The MECS Study Center has completed its National Statistical Survey, conducted for the first time in organic form among Italian manufacturers of plastics and rubber processing machinery, equipment, and moulds.

The general picture is of a sector that produced revenues of 3.74 billion euros in 2020, with nearly 76% of the total from exports, confirming the historical emphasis on exports by companies in the industry. The nearly 350 companies surveyed, employing just over 13,000 people, are mainly concentrated in Lombardy (55%), Emilia-Romagna (15%), and Veneto (13%). Most of them are small companies.

The greater level of detail in the survey with respect to its predecessors also makes it possible to identify the shares of production by application and technology.

The first indicator shows that packaging is the main outlet market for Italian manufacturers, and more specifically food packaging (30% of turnover), followed by other packaging segments (approximately 12%); automotive absorbs 19% of production, and construction 11%; medical, agriculture, electronics/electrotechnics, and other applications following in decreasing order with shares ranging from 4% to 2%.

As for machinery types, we observe that the category of the extruders, with 17% of the total, represents the largest core of turnover for the sector; they are followed by auxiliaries at 12%, injection moulding machines at 11%, and blow-moulding machines at nearly 7%. Recovery and recycling lines and the macro-category of rubber processing machines each approach a share of 6%.

► A Più S.r.l.
www.a-piu-srl.com

From the Simple to the Sublime



Series 800 crosshead for two to six layers

The latest generation of the **Series 800 crosshead** is designed to run two to six layer extrusions for high quality, high accuracy 1/8" to 6" OD tubing for medical, automotive, appliance and industrial applications.

Ideal for fluoropolymer multi-lumen, multi-layer tubing for fuel lines or thin layer combinations of polymers and adhesives to 0.02mm or less.

Features patented **Guill Feather Touch®** concentricity adjustment to eliminate leaking.

Please visit www.guill.com



10 Pike Street
West Warwick, RI 02893
USA
sales@guill.com Attention: Bill Conley

Digital Plastic Recycling – Sustainability Award 2021

■ R-Cycle – the digital product passport for sustainable plastics – receives the German Sustainability Award 2021 in the “Packaging” category. The award is conferred by the German Institute for Service Quality (DISQ), the German news channel ntv, and DUP UNTERNEHMER (German Entrepreneurship Platform for Digitalization and Sustainability).

Plastic packaging has become an indispensable part of our everyday lives and there is often no alternative – such as in medical technology or in the packaging of perishable foodstuffs. However, the problems associated with the growing global demand for plastic packaging cannot be overlooked and are becoming increasingly acute. For example, even in the “recycling land” of Germany, only about 6% of plastics from domestic waste are recycled to make equivalent new products. The largest percentage of over 65% is burned in waste incinerators*.

One reason for the low recycling rate is the present difficulty to identify the different compositions of plastic packaging in the recycling process. Sorting is considerably improved when a digital product passport is affixed to plastic packaging to display this information. R-Cycle is such a digital product passport. It is based on an open standard and is machine-readable via special markings.

R-Cycle automatically registers all recycling-related properties during packaging production and passes this information along the value chain. Waste sorting plants can then identify recyclable packaging and form recyclable fractions. This is the basis for obtaining pure and therefore high-quality recyclates as part of efforts to set up a functioning circular economy.

“We are delighted to receive this award,” says Dr Benedikt Brenken, Director of the R-Cycle Initiative. “Digitalization and sustainability are two megatrends that we have integrated beneficially in R-Cycle. The use of a digital product passport, as also required by the European Union, offers enormous potential to increase the recycling rate of plastic packaging.”



Dr Benedikt Brenken, Director of the R-Cycle Initiative, accepts the award on behalf of the consortium

R-Cycle is under development to market maturity by leading companies and organizations along the entire plastic-packaging life cycle. Besides improving product sustainability, manufacturers can increase their process efficiency and product quality by using a digital product passport. Detailed information about the raw materials used speeds up production and registering the product properties adds value for customers in downstream processes.

*Conversio Study 2017 (Stoffstromdiagramm Kunststoffe in Deutschland) / Plastikatlas Heinrich Böll Stiftung

The R-Cycle consortium:

Arburg, Brückner Maschinenbau, Comexi, Erema Group, GS1 Germany, Institut für Kunststoffverarbeitung (IKV), Kampf, Kautex Maschinenbau, Multivac, Prodata, Reifenhäuser Group, Steinert

► R-Cycle
www.r-cycle.org

Economic Situation in the European Plastics Industry

■ The mood across all European plastics industry sectors and regions seems to be rather optimistic, even if the global supply-chain crisis and pandemic-related problems are impeding business performance throughout Europe. These are the key results of the 6th half-year readers survey on the European plastics industry’s business performance and outlook, conducted by PIE – Plastics Information Europe in July 2021. The questionnaire was open to PIE subscribers and other industry players, and data has been gathered from more than 300 participants from 51 countries.

Having struggled with the pandemic for longer than expected, a heavy percentage of our respondents are expect-

ing to hire more staff in the second half of 2021, despite the fact that a number of them don’t expect coronavirus-related problems to go away anytime soon: one-third of the European industry players say they’re yet to face the worst, with less than half saying they have fully bounced back from the dip caused by the pandemic.

Business performance in H1 2021 for a large number of managers in the European plastics industry equaled or outpaced activity in H2 2020, with a huge majority in the Benelux region declaring that business was so far better this year than the second half of last year. The most optimistic for better business in H2 2021 are the continent’s construction materials and technical parts producers.

As for capital investment plans, a majority of the companies surveyed said their short and medium-term plan for tangible assets remained unchanged during H1 2021, with about one-third reporting an increase in capital spending than originally planned. Interestingly, in our previous survey in January 2021, more than 84% of managers had said capital expenditures in 2021 would either match or exceed outlays in 2020.

In light of logistical problems, the plastics industry's top concerns for business performance in H1 2021 were feedstock availability and the cost of materials. Nearly all plastics producers, compounders, distributors and product traders complained about the lack of availability for raw materials in the first half. The situation was better, but far from relaxed, for machine makers and recyclers.

The outlook for H2 2021 is also guided by these ongoing issues. Two-thirds of respondents said they survived the Covid-19 crisis quite well, with nearly half already having returned to pre-pandemic levels. However, 40% predicted their recovery in 2022 at the earliest or said they currently cannot foresee when it will happen, though half of the respondents see the tense supply situation in the global plastics markets easing towards the end of the year. More than half of the survey participants also said

that diversification of the supply chain could support the stability of supply.

The greater level of detail in the survey with respect to its predecessors also makes it possible to identify the shares of production by application and technology.

The first indicator shows that packaging is the main outlet market for Italian manufacturers, and more specifically food packaging (30% of turnover), followed by other packaging segments (approximately 12%); automotive absorbs 19% of production, and construction 11%; medical, agriculture, electronics/electrotechnics, and other applications following in decreasing order with shares ranging from 4% to 2%.

As for machinery types, we observe that the category of the extruders, with 17% of the total, represents the largest core of turnover for the sector; they are followed by auxiliaries at 12%, injection moulding machines at 11%, and blow-moulding machines at nearly 7%. Recovery and recycling lines and the macro-category of rubber processing machines each approach a share of 6%.

Plastics Information Europe
www.pieweb.com

MOLECOR
Orienting the future

TOM®

**PVC-O pipes of the highest quality.
Product guaranteed 50 years**

50 TOM PVC-O Pipes **YEAR WARRANTY**

Maximum resistance to impact | Long useful life | Great ductility

Higher hydraulic capacity | Full watertight | Maximum resistance to water hammer

Unbeatable physical and mechanical properties

The best alternative for the conveyance of water under pressure

The most efficient and environmentally friendly solution

From PN12.5 up to PN25 bar | From DN90 up to DN800 mm

info@molecor.com | www.molecor.com | +34 911 337 090

Guarantee exclusively applicable to PVC-O pipes manufactured in the Loeches production center (Madrid) with AENOR Product Certificate No. 001/007104 in accordance with UNE-EN 17176: 2019

Operational Turnaround

■ The restructuring at ILLIG Maschinenbau has shown results, and operational turnaround is in sight. After almost three years in a difficult market environment with reduced order volumes, the company can now look to the future with confidence during its anniversary year. The family-owned company's thorough restructuring initiative succeeded in roughly halving losses from 2020 and is set to bring the company back to a profitable operational position by the end of 2021. The difficult situation, which had already begun making itself apparent over the course of 2019, was caused by customer-side investment reluctance worldwide. Politically motivated trade disputes, global discussions about plastic

(Picture: ILLIG)



* 2021 erneut ausgezeichnet

and packaging fueled by negativity, and the far-reaching effects of Covid-related lockdowns across the globe with severe disruptions in all logistics chains have created pervasive uncertainty. Economic normality began to make a return after the first half of 2021. Mechanical engineering is starting to see rising numbers of orders again. Nevertheless, this is a clear signal to remain firm in pursuing restructuring measures to address the clearly

defined challenges stemming from global market uncertainty, ongoing critical discussions of plastic and packaging, and the economic effects of the COVID-19 pandemic.

"We reacted to the situation early on, and at the beginning of 2020 we had already taken initial measures to compensate for declining sales and profit," explains ILLIG CEO Carsten Strenger. "ILLIG is, and will remain, an outstanding mid-size mechanical engineering company with an exceptional team of skilled professionals who will continue developing groundbreaking technological solutions for our customers. The measures we initiated last year are now showing positive effects in 2021. We are more responsive to the markets and are now much closer to our customers. We will continue pursuing these goals. What still counts is to respond to customer demands emerging from global market realities with high flexibility and a strategic focus."

With Circular Thinking, ILLIG supports the concept of the cyclical economy and pursues clearly defined sustainability goals: reducing, reusing, sorting, recycling and renewing. ILLIG tool, production and packaging systems are flexible on the material side. They use process-safe biodegradable plastics, recycled goods, plastic-cardboard combinations or post-consumer films, even including 100% cardboard applications.

Carsten Strenger looks to the Next 75 future with confidence: "The next major development from our company is the industrial manufacture of packaging made from thermoformable paper using existing ILLIG production systems – another sustainable solution from the leader in innovation, and fully in line with current sustainability strategies in target countries."

ILLIG Maschinenbau GmbH & Co. KG
www.illig.com

Acquisition – Position in Extrusion and Blow Moulding Applications Massively Strengthened

■ As of 1st July 2021, motan holding gmbh has taken over all shares Bolder automation GmbH. With Bolder's expertise in customised solutions and its international customer base, motan will sustainably strengthen its portfolio of products and solutions for the blow moulding and extrusion sectors. Founded in 1993 by Dr Georg Bolder and managed by him since then, the company specialises in the control of continuous processes in the plastics industry, especially on extrusion and blow moulding lines. Dr Georg Bolder: "Our strengths are customer- and process-specific solutions as required in extrusion. For this purpose, we use measurement and con-

trol technology on the extrusion lines and integrate material conveying, dryers and dosing & mixing systems. For OEM customers, the control and operation of these process parts is transferred to the complete extrusion line. Processors benefit from a holistic solution when modernising their lines."

Bolder has been cooperating with the motan group in various development and customer projects since 2001. With the takeover of Bolder, Managing Director Sandra Füllsack expects a number of positive effects: "Over the past decades, Bolder has built up process technology knowledge and an excellent reputation in the industry. In addition, the employ-

ees know motan's products very well from previous projects. This gives the motan group much better access to the international extrusion world – and as of now Bolder can utilise motan's international sales network."

The modular control technology developed by Bolder makes it possible to network material conveying and dosing & mixing systems from various manufacturers with different extruder types and – in conjunction with modern measuring technology – control them precisely. Even hard to handle raw materials and exacting dosing tolerances can be controlled with a high degree of process reliability. Process and control know-how for the realisation of customised applications are available from one reliable partner. In addition, the close proximity of Bolder and the Technical Center of motan-colortronic gmbh in Friedrichsdorf, Germany, provides the Bolder team with excellent testing and development facilities.

"Customer enquiries for raw materials handling systems are becoming more and more individual, this applies to injection moulding, but especially to extrusion," notes Sandra Füllsack. "This is where we are bringing additional expertise in-house."

Dr Georg Bolder will lead the company as managing director until August, 31th 2021 and will act in an advisory capacity until the end of the year. In addition, he will accompany two employees working in the company until the end of their dual studies. Bolder is to continue at the Limburg, Germany, location with all eleven employees and as a separate brand.



*Sandra Füllsack: "Through this acquisition we bring additional expertise in-house." (in picture Dr Georg Bolder and Sandra Füllsack)
(Image: motan group)*

motan Group
www.motan.com

Changes in Management Board

■ Dr. Harald Nippel, KraussMaffei Group's Chief Financial Officer (CFO) and Member of the Executive Committee, leaved the company effective May 31, 2021 on his own wish.

Dr. Nippel started his successful career at KraussMaffei in 2016 as CFO of the Group. Since then, he has driven forward key initiatives and projects in his areas of responsibility

Dr. Harald Nippel (Photos: KraussMaffei)



Jörg Bremer



worldwide and thus made a significant contribution to the positive development of KraussMaffei.

"We would like to thank Harald Nippel for his services, valuable contributions and extensive personal commitment to KraussMaffei" says Dr. Michael Ruf, CEO of Krauss Maffei Group.

KraussMaffei has appointed Jörg Bremer as new Chief Financial Officer (CFO) of the KraussMaffei Group and the Shanghai-listed KraussMaffei Company Limited (KMCL), effective July 1, 2021. Bremer will also become a member of the KraussMaffei Group Management Board.

"A traditional company with a great global reputation, KraussMaffei has embodied the pioneering spirit and innovation in large-scale machine manufacturing for over 180 years. It's an honor to have the chance to help shape such a company strategically and operationally as CFO. I look forward to contributing my experience and know-how to KraussMaffei's positive development, especially with regard to digitalization, standardization and growth," explains Jörg Bremer.

KraussMaffei
www.kraussmaffei.com

South African Packaging Manufacturer Acquired



The company Verigreen Packaging specialises in bottles and canisters for lubricants (Copyright: ALPLA)

■ The ALPLA Group acquired the lubricants division of the South African packaging manufacturer Verigreen on 7th July 2021. Verigreen Packaging has a workforce of 25 employees at its site in Durban. "This acquisition is the perfect fit for our strategy," explains Mike Resnick, Managing Director of Sub-Saharan Africa at ALPLA. "It offers us an in road into a market segment in which we have not been present in southern Africa until now as well as generating synergies for our existing customers and giving us opportunities to further diversify our portfolio." With the acquisition, ALPLA is increasing its involvement in this region. In 2017, it acquired Boxmore Packaging, the African market leader in the manufacture of PET bottles, PET preforms and caps. A modern production facility together with a regional head office is currently under construction in Lanseria near Johannesburg. There is another production facility near to Cape Town. The acquisition of Verigreen Packaging adds a plant in the country's third largest city, Durban, to the portfolio. Outside of Africa, the ALPLA Group already has a wealth of experience in the production of packaging for lubricants.

■ ALPLA Group
www.alpla.com

Appointment to the European Senate of Business

■ Alaaddin Aydin, VP MAAG Germany / Managing Director, was appointed to the Senate of Economy Europe. Alaaddin Aydin represents MAAG Germany GmbH as Senator in the European Senate of Business. The appointment took place during the Senate's Wine Blossom Festival on June 12, 2021 at the Sankt Annaberg Winery in Burrweiler, Germany. Mr. Alaaddin Aydin received the appointment certificate from Norbert Streveld, Chairman of the Executive Board Senate of Business Germany and Dr. Christoph Brüssel, Chairman of the Executive Board Foundation Senate of Business.

The Senate of Business is made up of personalities from business, science and society who are aware of their responsibility to the state and society. Together, they contribute to the practical implementation of the common good-oriented goals of sustainability in the context of an ecological / social responsible market economy.

To achieve its goals the Senate of Business is in dialogue with representatives from politics and science. Fairness and partnership in business life as well as the social competence of entrepreneurs and executives shape the work of the Senate. The ethical principles and values of the Senate's community are the basis and guideline for the economic actions of the members of the Senate.

From left to right: Norbert Streveld and Dr. Christoph Brüssel congratulate Alaaddin Aydin to his appointment



■ MAAG Group
www.maag.com

Management Succession

■ Kautex Maschinenbau is consistently continuing the implementation of its new vision, mission and philosophy: as successor to Andreas Lichtenauer, Christian Pum took over as Managing Director Sales of the Kautex Group on August 1, 2021. CEO Thomas Hartkämper will additionally be responsible for the Service business unit in the future. The succession plan follows a long-term change process and is part of the new orientation of Kautex Maschinenbau.

At the end of 2019, Kautex Maschinenbau responded consistently to massively changed market conditions. With success: The company has already implemented the change quickly, consistently and successfully in many areas of the company.

Thomas Hartkämper, CEO, explains: "Part of this strategy is also the succession planning in the Group's management, always in line with the new vision, mission and philosophy for the future Kautex. Now it is time to initiate this change in sales and service as well." He added: "In this context, we would like to thank Andreas Lichtenauer for his many years of dedication and passion for Kautex Maschinenbau. He has helped shape a successful era for the company. Andreas Lichtenauer was not only instrumental in building up the Chinese market. His success in building up the tank business worldwide has also had a lasting impact on the company and the entire industry.

■ Kautex Maschinenbau GmbH
www.kautex-group.com

Advisory Board Extended



The Managing Directors of the GINDUMAC Group, Janek Andre (left) and Benedikt Ruf (right), welcome Nadine Despineux (center), Managing Director of KraussMaffei Technologies GmbH, as a new member of the Advisory Board

■ Nadine Despineux is a new advisory board member at used machinery dealer GINDUMAC. The Managing Director of KraussMaffei Technologies GmbH has many years of industrial experience and is the driving force behind the innovation processes at the Munich-based manufacturer of plastics processing machines.

“We are delighted with Mrs. Despineux’s decision to become more actively involved personally at GINDUMAC. Her impulses and the synergy effects in the cooperation with KraussMaffei once again open up valuable perspectives for our strategic and operational business development,” describes Benedikt Ruf, Managing Director of the GINDUMAC Group. Under the motto “Pushing Forward”, GINDUMAC is pursuing a targeted growth strategy this year by strengthening its core markets and developing new market potential in growth regions such as the MENA or CIS region.

“The advisory board has confirmed that we are strategically on the right track. Together we have revised our current action plan and go with new impulses into the implementations for the coming months,” comments Janek Andre, CEO of the GINDUMAC Group.

At the beginning of 2021, the GINDUMAC Group decided to establish an advisory board to support the strategic development of the company.

The advisory board includes Mag. Alexander Eisler, (Owner and Managing Partner of WEILER Werkzeugmaschinen GmbH and Kunzmann Maschinenbau GmbH), Dr. Hans Ulrich Golz (Management Consultant), Dr. Dominik Benner (Owner & CEO of The Platform Group GmbH & Co. KG) and Nadine Despineux (Managing Director of KraussMaffei Technologies GmbH).



27th Fakuma
International trade fair
for plastics processing

12.-16. October 2021
 Friedrichshafen



- Injection moulding technology
- Thermoforming and forming technology
- Extrusion technology
- Additive manufacturing / 3D printing technology
- Tooling, materials, process engineering and services



SCHALL - HYGIENE & SAFETY CONCEPT

www.fakuma-messe.com

#fakuma2021

Organizer: P. E. SCHALL GmbH & Co. KG

+49 (0) 7025 9206-0

fakuma@schall-messen.de

Construction Competencies in Blown Film Lines Consolidated

■ With effect from July 1, the Reifenhäuser Group merged its blown-film business units Reifenhäuser Blown Film and Reifenhäuser Blown Film Polyrema, which have so far operated independently, in order to cope with ongoing growth in this sector. This move consolidates the Group's competencies even more than before to form a joint brand, Reifenhäuser Blown Film.

Initially the change is purely organizational and will give the new business unit more leverage in developing new technologies for standard and special machine tool manufacturing. The change will be incorporated in the company's statutes as of next year on July 1, 2022.

Bernd Reifenhäuser, CEO of the Reifenhäuser Group: "We have exciting tasks to solve, especially when it comes to the digitalization of blown-film production and the resource-conserving use of plastics in keeping with the concept of a circular economy. Jointly, we can then speed up developments in this direction without the delay of internal barriers – and this will also bring our customers enormous benefits."

The joint managing directors of the merged business unit Reifenhäuser Blown Film are Dr. Andreas Neuss and Marcel



Managing directors of Reifenhäuser Blown Film:
Marcel Perrevort, Dr. Andreas Neuss (FLTR)

Perrevort. Both have several years of experience in executive positions in the blown-film business segment of the Reifenhäuser Group.

Reifenhäuser Gruppe
www.reifenhauer.com

Investing in Research on Sustainable Packaging Technologies

■ KIEFEL opened a new Technology and Material Center at its headquarters in Freilassing. Thereby the mechanical engineering company's is increasingly investing in its own research activities into sustainable packaging solutions with a focus on natural fibers. The market-leading company for plastic thermoforming and joining technology opened up the additional business area of "Fiber Thermoforming" internationally last year. In future, the center will be used for material research and tests, as well as for sample production and machine demonstrations.

"The Packaging Technology Center and the connected Material R&D Center, deepen our materials expertise and allow us to support our customers even more closely in the development process for everything related with fiber materials,

Kiefel is pushing ahead with thermoforming with natural fibers in the new Technology and Material Center at its Freilassing headquarters (© KIEFEL GmbH)



products and machines.", explains Matthias Hausmann, Head of Central Development. "We are thus consolidating our role as a holistic solutions provider." With this investment, Kiefel intends to develop and use even more sustainable technologies, processes and materials.

The Material R&D Center is the starting point for product developments for customers. Here, Kiefel researches, analyzes, and categorizes various natural fibers and designs coating concepts for packaging made from natural fibers.

In the Packaging Technology Center in Freilassing, Kiefel demonstrates its extensive machine portfolio for the production of fiber packaging to its customers.

A sustainability exhibition is also integrated into the Packaging Technology Center. Cornelia Frank, Head of Sustainability at Kiefel emphasizes: "We have been involved in various initiatives for a number of years, for example helping improve plastics recyclability. As a mechanical engineering company, we want to actively take responsibility in order to become the leading solution provider for the development and implementation of the most sustainable technology." The "Rethinking Concept" has long anchored this claim in the company's DNA.

KIEFEL GmbH
www.kiefel.com

Fourteenth Blow Molder Added

■ Longtime Davis-Standard customer, Eagle Manufacturing, recently commissioned its fourteenth Davis-Standard blow molding machine to support industrial safety markets. The 40-pound dual accumulator head machine, installed in May, is primarily being used for molding large storage drums made of chemical resistant high-density polyethylene. Eagle Manufacturing is one of the leading sources of industrial storage, handling and security products in the world. This includes fire prevention safety equipment for hazardous materials, environmental protection spill containment devices, and specialized storage products. Disposal cans, safety cabinets, column protectors, outdoor ashtrays, parking stops, spill containment pallets and rack guards are all part of Eagle Manufacturing's extensive product portfolio.

"We have been a Davis-Standard customer for over 30 years," said Dave Harvey, Eagle Manufacturing's Vice President of Operations. "Our highly skilled craftsmen and operators have grown to trust Davis-Standard for reliability and great equipment performance. This latest blow molder has already been excellent with even faster cycle times than our existing machines.

Gary Byers on the left and Rocco Salatino on the right with the SE16540D Blow Molding System



One of the best improvements from previous models is the cooling design with forced air blowers on the barrel. We're able to attain consistent process temperature control without dealing with the maintenance of a closed-loop system."

As with prior installations, Davis-Standard collaborated with Eagle Manufacturing's team to engineer machine specifications according to their processes and product range. Custom feedscrew designs, part consistency, responsive parison control, cycle-to-cycle precision and efficient wall distribution have been instrumental in helping the company deliver high-quality products with excellent value to their customers. In addition to supplying Eagle Manufacturing with new equipment over the years, Davis-Standard has retrofitted used non Davis-Standard machines to improve performance. Quality control upgrades, spiral core tube retrofits, head reconditioning and replacement screws have added internal efficiencies, which are essential to Eagle Manufacturing's one-stop operation, which takes products from concept to design, to testing and market-ready.

"Our business is built around three principles; integrity, innovation and customer service," added Harvey. "Our product design, methods and processes, and getting products to market in a timely manner have been foundational to our growth and success. We are grateful to have a partner like Davis-Standard that supplies the machinery technology we need to provide market leadership and superior products."

■ Davis-Standard, LLC
www.davis-standard.com

Eagle Manufacturing
www.eagle-mfg.com

Reorganized Management

■ Effective June 2, 2021, Ulrich Bartel has assumed leadership of the Coperion Group as President of Coperion. He succeeds Kimberly K. Ryan, who was appointed Executive Vice President of Hillenbrand, Inc., Coperion's parent company, on June 2. She and her team have positioned Coperion as a global industry leader over the past six years.

Ulrich Bartel has been with Coperion since 1990 and has held a variety of positions at various Coperion sites around the world. He has spent a total of twelve years in various leadership positions at Coperion companies in Japan, China, Singapore and the USA. Since 2014, he has headed the Polymer Division as President, which incorporates all product areas related to plastics.

On June 2, 2021, Markus Parzer replaced Ulrich Bartel as President of the Polymer Division. Markus Parzer joined Coperion in 1992. Following his training at the company and industrial engineering studies at the University of Applied Sciences Esslingen, Germany, he held various leading positions at the Stuttgart extruder production plant before taking over as



Ulrich Bartel, newly appointed President of Coperion, and Markus Parzer, President of Coperion's Polymer Division (Photo: Coperion)

head of Order Management in 2014. With his appointment as President of the Polymer Division, he is now responsible for the entire product range related to plastics.

■ Coperion GmbH
www.coperion.com

Sustainable Solutions from Plastic and Cardboard

■ At Equiplast in Barcelona, Spain, from September 14 to 17, ILLIG will present its solutions for sustainable packaging at our partner ROEGELE's booth D30 in hall P3. ILLIG will illustrate how the production of sustainable all-paper blisters made of recycled cardboard with different designs and contents is possible on a single, flexible packaging system. In addition, the company will present plastic-cardboard I-PACK® brand solutions with plastic reduction of more than 50%. Because less is more: reduce – reuse – separate – recycle – renew.

ILLIG will present the latest version of the HSU 35b packaging series. The system is suitable for safe sustainable blister packaging made of cardboard-plastic-cardboard combinations (double card blister) or solid cardboard for non-food products. The economical and efficient HSU 35b is designed for variable blister heights and can be configured with 3, 6, 8, 10 or 12 transport pallets for any application. The compact machine

Environmentally friendly solutions from ILLIG – over 50% less plastic with I-PACK® (Picture: ILLIG)



adapts to the individual requirements of packaging manufacturers with numerous equipment features.

Examples include automatic product feeding, product presence control, product inlay (fixation in the carton blister), inserts for brochures, marking systems, code readers and blister lifters. ILLIG packaging systems are modular, flexible and efficient that enable brand owner and co-packers the freedom to design sustainable packaging for a variety of end markets.

Eco-friendly applications are the focus of attention for packaging manufacturers. Sustainable and easily recyclable packaging solutions that meet all requirements for hygiene, product protection, logistics and convenience are in demand. With I-PACK® (ILLIG intelligent packaging), ILLIG offers easily separable plastic-cardboard combinations with reduced plastic use. The sustainable I-PACK® trays, cups and lids are manufactured with a great deal of know-how on established production systems. The packaging experts at ILLIG accompany customers throughout the entire "Pactivity® 360" development process, from the initial idea to the commissioning of the production system. ILLIG has implemented sustainable and recyclable packaging solutions that can be perfectly sealed to maintain a protective atmosphere. I-PACK® trays save valuable resources with more than 50% reduced plastic content in the PP or PET plastic inlay. The stabilizing cardboard sleeve is easy to separate. The large sealing rim enables a tight closure.

Note: Terms marked with ® are registered and protected trademarks of ILLIG Maschinenbau GmbH & Co. KG.

ILLIG Maschinenbau GmbH & Co. KG
www.illig.com

Generation Change

■ Effective July 1, 2021 Dr. Paul Walach becomes Managing Director of Reifenhäuser Cast Sheet Coating together with Karsten Kratz. With this move, the Reifenhäuser Group business unit specializing in cast film, sheet and extrusion coating lines introduces a generation change at executive management level. Bernd Reifenhäuser, CEO of the Reifenhäuser Group, explains: "We are placing young executives in charge but with experienced executives to flank them. This makes for a good mix of know-how, diversity, and stability."

Dr. Paul Walach holds a doctorate in mechanical engineering and has already worked successfully for the Reifenhäuser Group in various positions over a period of seven years – the last three of them as technical director of Cast Sheet Coating. Karsten Kratz, in addition to his function as CFO of the Reifenhäuser Group, was the sole Managing Director of Cast Sheet Coating until recently.

"Personally, continuing along our current track of growth represents a motivation as well as a responsibility," explains Dr. Paul Walach. "In the future we will focus on combining our

expertise in special machine tool manufacturing with field-proven components from our modular system and deliver clever solutions on the themes of the Circular Economy and digitalization. To achieve this, we keep close contacts with film manufacturers. We are very much looking forward to transforming their current challenges into opportunities for the future."

Reifenhäuser Cast Sheet Coating
www.reifenhauser.com

Dr. Paul Walach (Photo: Reifenhäuser)



Large Die Cart with Crosshead Introduced



■ Guill Tool announced the immediate availability of its new die cart with easy disassembly and reassembly. It features a high volume, adjustable center accumulating crosshead. This crosshead is designed to produce a smooth linear bore and provide jacketing over various substrates. The crosshead's maximum thru core is 18," while its' maximum die ID is 23". Built to handle thermoplastic applications, the crosshead includes tooling and isolation sleeve design. Additionally, the tooling section features quadrant heating. Guill's crosshead stand is equipped with an integral alignment station and concentric role guide. The stand is also an integral cleaning station, so clients don't need to remove the crosshead for cleaning. Lastly, this crosshead has "on-the fly" catenary adjustment and can be easily maintained with simple hand tools.

"Micro Medical" Extrusion Tooling

■ Guill Tool & Engineering introduced the new Micro Medical, an extrusion crosshead that uses micro-fine adjustment screws for precise concentricity adjustment. The precision of concentricity reaches 0.008" or finer per revolution. This single point concentricity adjustment is a unique Guill innovation for the extrusion of thin-walled and precision ID/OD medical tubing. One adjustment bolt controls 360° of adjustment. Features of the Micro Medical crosshead include a patented cam-lock deflector for quick changeovers, with a residence time of one minute at .5 lb/hr material flow, optimized usage with extruders measuring ½" and ¾", and a max die ID of .250." Additionally, the Guill Micro Medical crosshead offers great flexibility to its users. It not only accepts both vacuum and micro-air accessories, but is also ideal for pressure and sleeving applications. Fluoropolymer designs are available upon request.

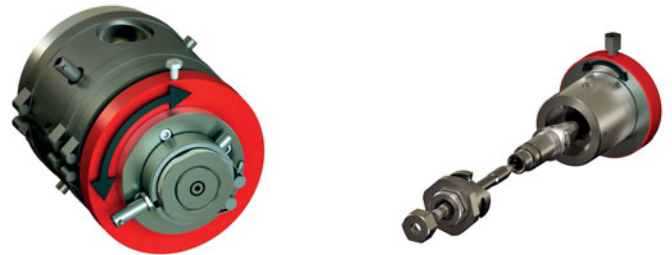

Rotary Extrusion Dies with 2X Increase in Speed

■ Guill Tool announced a new design for its high-production rotary models, both inline and crosshead style. A 2X increase in speed, with models running to 1000 RPM depending on the application, are now available in the Guill line of patented rotating tip & die designs. By rotating the tooling in relation to the material flow, a rotary head increases the wall strength of an extrusion, thereby allowing a thinner wall with less material and the corresponding cost savings for

the user. Typical applications for rotary heads include medical and multi-lumen tubing plus various high-end extrusions with interlocking layer or multiple striping requirements. Features offered on these new rotating extrusion dies include counter-rotating tip & die, co-rotating tip & die, rotating die with conventional tip, rotating tip with conventional die, crosshead or inline, multi-layer, striping, certain profiles and optional quick-change cartridges that minimize cleaning downtime.

By using rotary dies, extruders can realize a cost savings due to the elimination of secondary processes, cosmetic enhancement of the end product with the elimination of weld or parting lines, plus reduction or complete elimination of ovality. Guill Tool offers its new high-speed rotary models as turnkey packages, complete with die cart, tools and all accessories for installation and maintenance.



The head on cart

■ Guill Tool & Engineering Co., Inc.
www.guill.com

Latest in a Row

■ Requirements for tires are ever changing and becoming more stringent, so do the demands on tire manufacturers. These demands translate directly to suppliers who are continuously facing new challenges. For decades, major tire companies have valued TROESTER co-extrusion, or CoEx® heads as the key element in their tire-component extrusion lines.

As a complete system supplier with an unrivaled range of CoEx® heads for up to 6 compounds, TROESTER is first choice for excellence in extrusion equipment designed to meet the most difficult industry requirements. This high level of experience and expertise has led to the development of the latest in the evolution of co-extrusion heads, the CoEx® 4+2.

The proven quadruplex hammerhead design allows selective compound changes along with modular tooling, and an opening width tailor-made to meet specific requirements. The CoEx® head incorporates two dedicated extruders for specialized compound application, thus giving it the designation CoEx® 4+2.

Today's challenges for tire design experts are the source of an ever-growing number of tasks for the CoEx® 4+2 head offering a wide array of applications, including the production of ultra-high-performance tires.

TROESTER CoEx® heads provide as well benefits when it comes to total cost of ownership and return on investment.



Multiple extrusion aggregate CoEx® 4plus2 (Photo: TROESTER)

The flexibility and precision to produce the highest quality co-extrusion, the highest degree of operational reliability and longevity, and a dedication to superior quality that is synonymous with TROESTER, make this head another example of sustainable technology made in Germany.

Author: Stefan Böttcher

► TROESTER GmbH & Co. KG
www.troester.de

Counteract Raw Material Prices with Measuring Systems

■ "Use a measuring device and automatically save material and money." This sounds simple and it is. At least for customers of SIKORA. The technology company is specialized in manufacturing measuring, control and inspection technologies. The systems are used worldwide in production lines for process optimization and quality control during the production of cables, hoses, tubes and plastic granulate. Especially against the background of the current shortage of raw materials and increased raw material prices, material saving is more important than ever.

SIKORA measuring technologies are used for process control immediately after the extruder, after the first cooling or at the end of the line and precisely measure relevant product parameters during the running production process.

The measured values, such as wall thickness, eccentricity, diameter and ovality, are available directly after starting up the system. They enable direct centering of the extrusion tools so that start-up scrap and safety margins can be

significantly reduced. This saves plastic pellets and costs. For example, optimal centering by the CENTERWAVE 6000 measuring system, based on millimeter wave technology, leads to a potential material saving of about 5 %.

Furthermore, the real-time measurement with the SIKORA measuring systems allows a reliable line control during the running process. Thereby, an automatic control to the minimum wall thickness is carried out by modification of the extruder output or the line speed. Safety margins in the wall thickness can thus be significantly reduced. The measured values are permanently logged and are available for quality management in the form of trend and statistic evaluations over the entire production cycle or the individual product length.

The use of SIKORA measuring technology leads to an optimized material consumption due to the possibility of a fast centering as well as the control to minimum wall thickness. Hence, users can specifically counteract the shortage of raw materials and the increasing raw material prices and automatically save material and costs with the help of measuring technology.



Counteract raw material prices with SIKORA measuring systems

► SIKORA AG
www.sikora.net, sales@sikora.net

Recyclability of Multilayer Films Certified

■ Institute cyclos-HTP GmbH has completed the series of tests commissioned by BASF SE to reassess the recyclability of polyamide 6 (PA6) in coextruded polyethylene (PE) / PA6-multilayer film structures in post-consumer packaging waste. The main result: Multilayer films based on PE/PA6 are certified to be recycling compatible for the PE film stream. This was analyzed for PA6 concentrations of up to 30 percent in original packaging films. This result is intended to form the basis for a review of the classification of PA6 in the "Minimum standard for determining the recyclability of packaging subject to system participation pursuant to section 21 (3) VerpackG (Verpackungsgesetz – German Packaging Act)" of the Stiftung Zentrale Stelle Verpackungsregister (Central Agency Packaging Register). In the Annex 3 to this standard, PA6 is to date listed as an "incompatible" component, for example, in the waste stream of the packaging group "film and PE-LD."

In addition to confirming the recycling compatibility of PA6 in the waste stream of flexible polyethylene packaging, cy-

clos-HTP has also classified PE/PA6 multilayer films as fully recyclable materials under certain conditions. This is the case while using so-called compatibilizers in PA6-containing film structures additionally to the PA6 content of up to 30 percent in original packaging films. This secures the homogeneous mixing of the polymers which are incompatible in these concentrations, although this is not absolutely necessary due to the dilution of PA6 in the real waste stream.

The certified compatibility of the examined PE/PA6 systems in the waste stream of flexible packaging applies to both new injection molding and blown film applications.

■ **BASF SE**
chemicals.basf.com/global/de/Monomers/polyamide_intermediates/mechanical-recycling.html
www.basf.com

Institut cyclos-HTP
www.cyclos-htp.de

PET Recycling – Decontamination and IV Control in One Step

■ Currently, the recycling of post-consumer PET Bottle Flake is well established and it has become a sought after secondary meantime. Increasingly, the focus is shifting toward using other sources of PET waste for recycling, such as post-industrial fibre waste and to other post-consumer sources of PET, such as thermoformed pots, tubs and trays.

The important difference in recycling these materials is that whereas with PET bottle flake, a certain IV drop extrusion is acceptable, the IV of fibre waste or thermoformed pots, tubs and trays is at a level that any further IV drop would result in unacceptable mechanical properties. Typically, the only answer is to install a complicated and/or energy intensive liquid phase or solid state IV boosting processes downstream of the extruder.

The Gneuss MRS extruder for PET offers unparalleled decontamination performance (and has

food contact approval for post-consumer waste without the need for any additional thermal treatment of the material). In addition to this, the new MRSjump version of this extruder provides a drastically increased surface exchange rate under vacuum so that partial polycondensation takes place within the extruder and it is possible to retain the input IV.

Additionally, the intense devolatilisation and long residence time of the polymer under vacuum can be controlled to provide a consistent output IV in spite of the inevitable variations in the residual moisture level of the input material.

The new Gneuss MRSjump therefore offers both decontamination performance to food contact levels and the ability to maintain and control the IV of the PET in one single extrusion processing step. There is no need to treat the material prior to extrusion and no need for an additional melt or solid phase IV boosting process in addition to extrusion.

The result: lower energy consumption, better material quality, greater flexibility, smaller machine footprint, lower complexity, less operator attention and the possibility of using types of raw material which were previously uneconomic to recycle.



■ **Gneuß Kunststofftechnik GmbH**
www.gneuss.de

Making Full Use of Measuring Technology

■ In the increasingly complex and automated tube and pipe production, measuring devices that reliably measure the required product parameters in real time have long been standard. However, measuring alone is no guarantee for excellent product quality. Only in combination with display and control systems such as the SIKORA ECOCONTROL series, the production process can be specifically controlled and optimized.

SIKORA offers three ECOCONTROL premium processor systems with 22", 15" or 8.4" TFT screens. All models are characterized by their simple and intuitive touch screen operation and a clearly arranged display.

Recorded production data can be stored on the internal SSD hard disk or directly on a server (Ethernet). Production reports (time, length and batch based) are also available for all ECOCONTROL models, which are used in quality control as well as in daily production to document product quality over a defined period of time.



At the ECOCONTROL measuring values of connected SIKORA gauges are visualized

SIKORA offers 3 ECOCONTROL processor systems



Furthermore, the ECOCONTROL series has all standard market interfaces, such as fieldbus or OPC UA, to conveniently transfer measurement data to the plant control system or server structures. The devices are therefore "Industry 4.0 ready" and ideally suited for use in modern tube and pipe extrusion lines with increasing levels of automation.

In addition to the display and documentation of measured data, the ECOCONTROL series offers its own automatic control with the SET POINT module. Here, the processor system automatically modifies the haul-off speed or the extruder speed to control to the nominal value of the wall thickness. The ECOCONTROL models thus enable a higher degree of automation (especially for older extrusion lines) and guarantee maximum process reliability with increased productivity and simultaneous compliance with the given specifications.

■ SIKORA AG
www.sikora.net

Additive Guide App

■ BYK has transformed its Additive Guide into an even more user-friendly and informative Additive Guide app. The fresh design comes with new technology and enhanced function-

View of the new BYK Additive Guide app

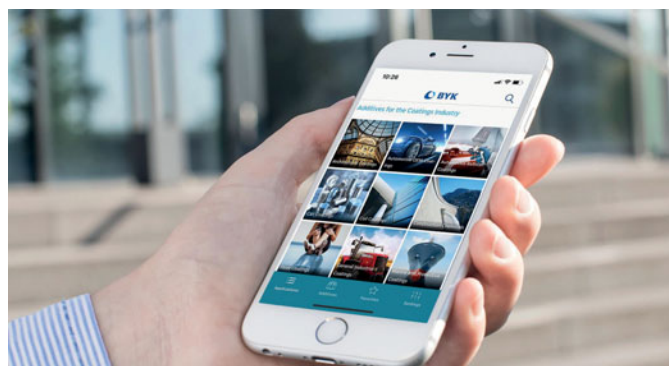

alities for users. Analogous to the BYK website, the app recommends products based on numerous filter options in multiple application fields. Users can also find comprehensive product information by searching BYK brands.

In addition to these familiar functions, the new app now also offers an additional product search function. Power users will appreciate the option of only having to enter the number of an additive – e.g. "190" for DISPERBYK-190. New products are labeled accordingly.

The new Additive Guide app was published in the App Store and in the Google Play Store recently.

■ BYK-Chemie GmbH
www.byk.com

Product Line Optimized

■ Maguire has made its ULTRA dryer touchscreen control even more powerful and feature rich by integrating the Company’s FlexBus Lite software into the platform’s powerful Arm Cortex microprocessor. FlexBus Lite, a standard feature on all touchscreen blender controls, is now integrated into the ULTRA dryer touchscreen controls, allowing users complete pump and receiver control in a cell, in a user friendly and straightforward control system.

FlexBus Lite features an Intuitive receiver and pump control – with features typically only found on larger central system

controls. It allows control of 1 vacuum pump and full system functionality control of up to 10 materials receivers. The Icon based touchscreen shows each of the receiver’s activity in real time whether it is calling for material, receiving material into it, or showing material discharging. The pump and receiver settings can be easily adjusted in real time by the operator. “With the dryer, vacuum chamber and material retention hopper on load cells – you are able to completely regulate the drying rate to the process rate. This allows the operator to program a shutdown to any specific day and time,” said Frank Kavanagh, vice president of sales and marketing. “The control system then monitors the rate so that the loader will stop calling for material and the dryer will be empty. With the control system monitoring the rate, this makes material changes even easier.”

FlexBus Lite on the ULTRA dryer offers full feature conveying control with several advantages:

- Designed to handle single or multiple dryers (up to 10 receivers) with ground level receiver and pump control. With one operator friendly touchscreen you can control the dryer’s onloading and offloading (and never set foot on a ladder to do so).
- Control of up to (10) receivers means that one ULTRA dryer can manage the conveying of an entire cell.
- Remote control capability makes mezzanine and elevated installations easier than ever for the operators.
- This important feature adds to the overall system value.

There are no additional controls necessary with FlexBus Lite – the control system can work with any Maguire product and also any third-party system.

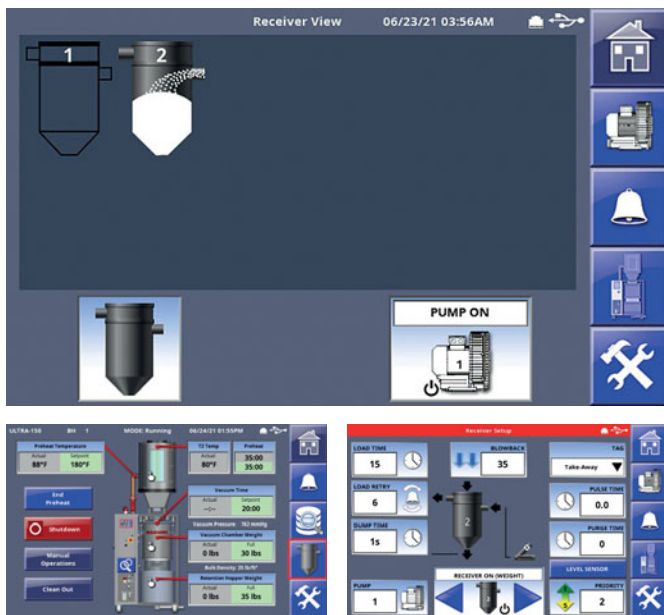

■ Maguire
www.maguire.com

Chemical Recycling Europe Joined

■ EREMA Group is a member of the Chemical Recycling Europe association as of July 2021. The Austrian plastics recycling machine manufacturer and provider of services related to the recycling process has been committed to improving networking and intensive cooperation within the plastics industry for many years. EREMA’s aim is to integrate recycling know-how into the value chain in such a way that benefits the environment, the industry, and society.

In order to achieve the European Union’s targets for plastics recycling and the use of recyclates, the technical capabilities of mechanical recycling need to be exploited to the full by expanding collection, sorting and recycling infrastructure and by further developing the technologies and end applications. For material flows where this recycling route is approaching its limits, it is important to regulate and apply additional pro-

cesses. Chemical recycling presents a viable option to recycle the maximum volume of plastic waste, and is the shared interest of the companies in the association.

“In many cases, mechanical processes are at the beginning of the process chain for chemical recycling in order to prepare input streams and ensure a reliable, continuous and energy-efficient material feed,” explains Klaus Lederer, Technology Research Manager - Chemical Recycling at EREMA Group GmbH. That is why EREMA extrusion technologies adapted to meet these specific requirements are already being used in existing chemical recycling plants. As a member of Chemical Recycling Europe, EREMA Group would like to contribute the know-how of the group of companies to the further development of chemical recycling processes, broaden the group’s own understanding of the needs of plant operators and promote cooperation.

■ EREMA Group
www.erima.com

Innovative Process for Bottle-to-Bottle Recycling

■ Polyethylene terephthalate (PET) is a high-value material that is on course to take over a key function in the plastics industry's path toward a circular economy. PET flakes can now be processed without pre-drying into pellets using Coperion ZSK twin screw extruders. Next they are condensed in the SSP (Solid State Polycondensation) reactor, and re-processed back into bottles again with the quality of virgin material.

PET recycle manufactured using this innovative process has received approval from the United States Food and Drug Administration (FDA) for food-contact uses. Thanks to the highly efficient plastification within the ZSK extruder, Coperion systems for this bottle-to-bottle recycling process achieve throughput rates between 2 and 8 tons per hour, therefore recycling companies profit from very high product quality, reduced operating and logistic expenses as well as from energy cost savings up to 30% in comparison to conventional PET recycling methods.

PET plays an ever more important role in recycling, due to the large volume of packaging materials in use today. PET is a very high-value material, possessing extremely good properties for reprocessing. Its continuously expanding use in single- and reusable bottles, as well as its recovery via deposit systems, add to its value. Correspondingly, it can be lucrative for companies to focus on PET recycling. Before PET can be reprocessed, it must first be shredded to flakes and then cleaned. Ordinary technologies require pre-drying, crystallization or agglomeration of the PET flakes following washing. However, using the specialized

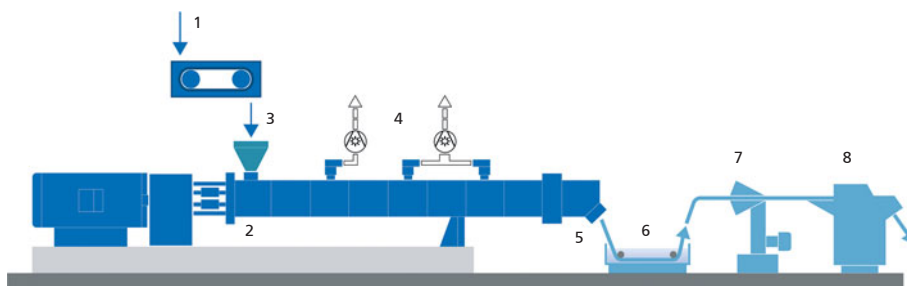

Typical set-up of a recycling system for economically processing PET flakes into PET pellets that can be used in turn to manufacture bottles: 1) SWB (Smart Weigh Belt) feeder; 2) ZSK twin screw extruder; 3) Addition of PET flakes; 4) Devolatilization of volatile components; 5) Discharge via gear pump and filter; 6) Water bath; 7) Strand drying; 8) Strand pelletizing (Image: Coperion)

technology from Coperion, the shredded PET can be fed directly into the ZSK twin screw extruder and compounded.

The shredded flakes are reliably fed into the ZSK extruder using high-accuracy SWB (Smart Weigh Belt) feeders or gravimetric feeders from Coperion K-Tron. In addition, other regrind materials, new materials, or mixtures can be added. Melting, intensive devolatilization, and complete homogenization take place in the ZSK process section before the melt is transferred via a gear pump and filter with an automatic screen pack changer to a strand or underwater pelletizer for pellet production.

Pellets are then condensed in an SSP reactor. The pellets' quality meets the requirements of virgin material.

With this direct processing of PET into bottles, recyclers profit particularly from the very high end product quality. Product handling in the bottle-to-bottle process is very gentle. The residence time in the ZSK extruder is very short and dispersion is very good. The ZSK extruders' high torque enables processing at low temperatures and with almost no viscosity loss. ZSK extruders' self-cleaning enables rapid recipe and color changes. Thanks to the ZSK twin screw extruder's very good devolatilization options, volatile components such as monomers, oligomers, and water are reliably removed and channeled away from the exhaust flow in suitable separators before discharging the process section.

Coperion ZSK twin screw extruders provide very good devolatilization with short residence times in the process section as well as very high dispersion, contributing significantly to high end product quality (Photo: Coperion)

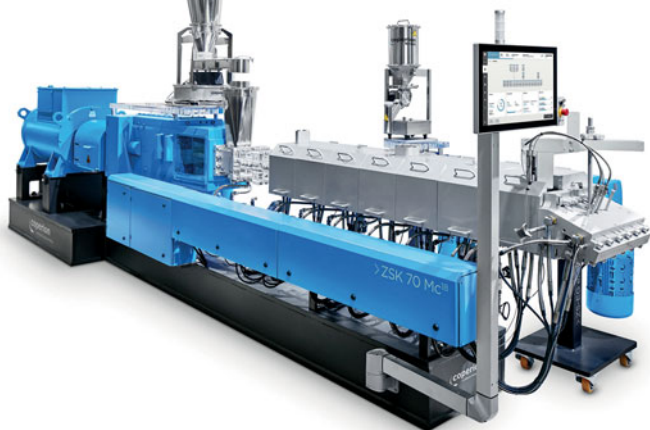

Partner for Recycling Companies

■ Ecomondo is a leading international trade fair for materials and energy generation. It will be taking place from the 26th to the 29th of October in Rimini on the Italian Adriatic coast – and Vecoplan will be there as a leading specialist for efficient recycling technologies and as a solution provider for mechanical material processing.

After many years of cooperation with an Italian partner, the recycling specialist company is continuing to strengthen its presence in the Italian market. The service division is being significantly expanded and an independent sales office is being established. Vecoplan complements its digital services with reliable local services and a dependable spare parts supply for its Italian customer base.

The company provides mechanical material processing solutions for the recycling industry, encompassing machinery, systems and service. Vecoplan will be demonstrating its professional expertise at Ecomondo with the Vecoplan Smart Center (VSC) and other innovative products. The VSC, a new and powerful digitalisation concept, offers a modern communication interface between Vecoplan and the customer's plant – the VSC.connect system. The user can access services such as document management and remote service. The integrated, intuitive VSC.control operating panel serves as a communication medium for the machine's control system and as a live link to the Veco-

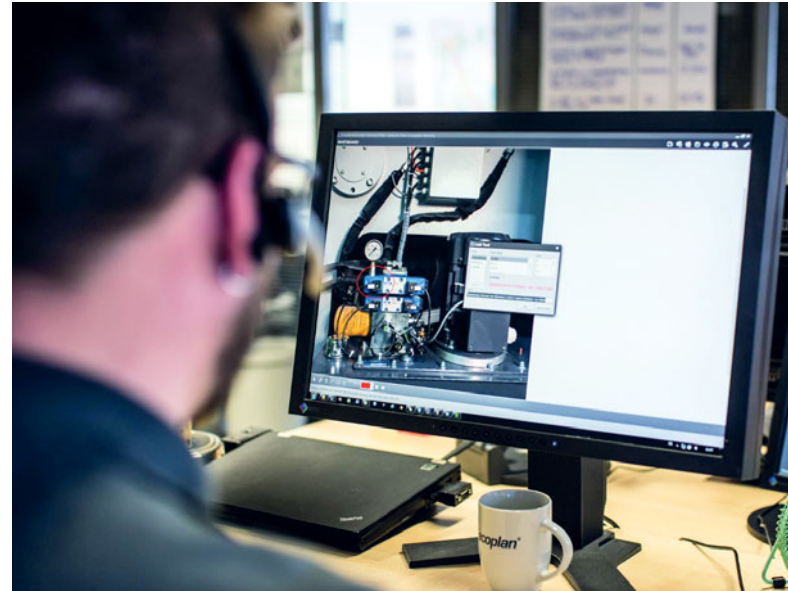

The system that sees it all – the Vecoplan technicians can access the control system or the customer's control panel, enabling them to detect, analyse and correct errors in real time (Source: Vecoplan)

plan technicians. This enables the solution provider to see everything that's happening on the customer's Vecoplan machines.

■ **Vecoplan AG**
www.vecoplan.de
 Ecomondo: Hall A2, Stand 033

Acquisition

■ The ALPLA Group is purchasing the Wolf Plastics Group to expand its product portfolio and sees growth potential in Central and South-Eastern Europe.



Wolf Plastics supplies SMEs and international key accounts in the construction, chemical and food industries with buckets, canisters and bottles (Copyright: Wolf Plastics)

In acquiring all the shares in the packaging manufacturer Wolf Plastics Group based in Kammern, Austria, ALPLA intends to use the company's expertise, in particular in the manufacture of plastic buckets and canisters, to expand its product portfolio. With its three production facilities in Austria, Hungary and Romania, Wolf Plastics is the market leader in its line of business in Central and South-Eastern Europe. The Austrian and Romanian competition authorities are currently examining the proposal. Closure of the deal is subject to regulatory approval.

"Wolf Plastics has decades of experience in product areas in which we want to increase our representation in order to expand our portfolio and grow in Central and South-Eastern Europe," says ALPLA CEO Philipp Lehner. ALPLA Regional Manager CEE Rainer Widmar adds: "Sustainability is becoming more and more important in the market segments covered by Wolf Plastics too. This is precisely where we at ALPLA can apply our expertise and our market position."

■ **ALPLA**
www.alpla.com

Sustainable All-Cardboard Blister Pack

■ At PackExpo Las Vegas, Nevada USA, from September 27 to 29, ILLIG will be demonstrating how the production of sustainable, all-cardboard blisters from recycled materials with different designs and contents on a single packaging system. Because less is more: reduce – reuse – separate – recycle – renew.

At booth 5963 in the South Lower Hall at the Las Vegas Convention Center, ILLIG will be presenting the latest packaging system of the HSU 35b series. The system is suitable for safe and sustainable blister packaging made of cardboard-plastic cardboard combinations (double card blister) or solid cardboard for non-food products. The economical and efficient HSU 35b is designed for variable blister heights and can be configured with 3, 6, 8, 10, or 12 transport pallets for any application. The compact machine adapts to the individual requirements of packaging manufacturers with numerous equipment features. Examples include automatic product feeding, product presence control, product inlay, inserts for brochures, marking systems, code readers, and blister lifters. ILLIG packaging systems are modular, flexible, and efficient,



ILLIG's HSU 35b flexible packaging system is suitable for sustainable blister packaging made of solid cardboard with inlay for product fixation (Picture: ILLIG)

allowing brand owners and co-packers the freedom to design sustainable packaging for a variety of end markets.

Note: Terms marked with © are registered and protected trademarks of ILLIG Maschinenbau GmbH & Co. KG.

ILLIG Maschinenbau GmbH & Co. KG
www.illig.com

Two Presentations at the Extrusion 2021 Conference in Rosemont, IL

■ Two exciting presentations from iNOEX at the Extrusion 2021 conference will provide insights and expert knowledge on the high-precision measurement and control systems that help achieve the highest product quality, process optimization and cost savings. With the help of this expertise, production can be taken to the next level.

On 21 September, iNOEX LLC President Adam M. Grier, will give a presentation on Progress in Inline Plastic Pipe Measurements – Radar Technology Comes to Plastic Extrusion. The presentation will present the latest progress in radar technology



*Adam M. Grier,
President at iNOEX LLC*

*Brad Allen,
Sales & Service Profile
Market at iNOEX LLC*



for inline plastic pipe measurements as well as a case study with cost-saving potentials when using automated control loop features.

On 22 September, Brad Allen, Sales & Service Profile Market at iNOEX LLC, will also give a presentation. His topic is: Where's My Weight? Maximizing Material Savings Through Precision Measurement. One of the costliest pieces in the extrusion of plastics, is the plastic material itself. Therefore, understanding the distribution of plastic within an extrusion profile is financially critical.

iNOEX GmbH
www.inoex.de
Stand E12,3 Hall F

New Design MEDD Extruder at Plastec West

■ Davis-Standard exhibited its upgraded MEDD (Medical Extruder Direct Drive) extruder design while running a swab stick line during Plastec West in Anaheim, Calif., August 10 – 12, 2021. The new MEDD design reflects medical industry expectations with components encased and stainless steel surfaces throughout for ease of cleaning. The running line featured a 1-inch MEDD along with DS-eVUE controls, a Con-

The sleek new MEDD design reflects medical industry expectations with all components completely encased and stainless steel surfaces throughout



air vacuum tank, puller/cutter and blowoff conveyor, as well as a Guill Tool die and Zumbach gauging system.

The sleek new MEDD design merges high-performance with cleanroom convenience. Stainless steel electrical enclosures, hoods and guards make for easy cleaning and a compact footprint. Cable management is improved with an enclosed plug plate area at the front of the machine including an access door, as well as a cable divider above the front door for wire bundling and separation. Specific to the extruder, there are provisions for cable routing, a bi-directional hood vent, and access doors to enclose the feed section cooling and material drain port. The access doors on both sides of the barrel allow the operator easy access for quick removal and changeover of the barrel assembly. Processors can take advantage of various MEDD models with interchangeable barrel assemblies in the following sizes: ¾ to 1 inch, 1 to 1.25 inch and 1.25 to 1.5 inch sizes, each with a 24:1 or 30:1 L/D. The DS-eVUE control has been a cost-effective option for medical processors. It is built for mid-size systems, involving up to three extruders, that require data collection or communication to third-party line controls. The control's PLC is customizable and available with graphic overviews, custom reports and real-time or historical trending capabilities. The DS-eVUE operator interface utilizes an industrial panel Windows®-based PC, a full-function SCADA (System Control and Data Acquisition), and a 19-inch widescreen monitor.

■ Davis-Standard, LLC
www.davis-standard.com

HQ Operations to Expanded Facility in Parsippany, N.J. Moved

■ Conventus Polymers has announced the relocation of its headquarters operations to a larger facility in the Parsippany, N.J. area. The new location is designed to meet the expanded demands of the company's growing plastics distribution business. The move represents the fourth expansion for Conventus over the last six years.

Conventus has signed a lease agreement which will more than double the size of the company's current facility. The new office space will provide room to grow and more space for collaboration with customers. The expanded facility will house human resources, finance, commercial operations, and the supply chain team, which includes customer service, import/export, warehousing, logistics, and material management. John Jorgensen, President of Conventus Polymers, and several other personnel have relocated from the Houston area to consolidate into the new location. "With a larger space and all of us under one roof, we expect this move to yield major synergies to deliver even greater service to our growing customer base," said Jorgensen.

Conventus also has approximately 20 people in field sales who are either direct employees or agents, along with a third-party logistics team. The company distributes its materials from approximately 25 local warehouses throughout the U.S.

Conventus offers a highly technical focus and unique expertise and strong relationships with key OEMs. The company's highly focused approach within key end-use markets and its ability to develop new applications is critical in expanding penetration of its high-performance polymer portfolio.

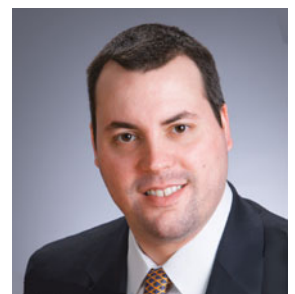

*John Jorgensen, President of
Conventus Polymers*

■ Conventus Polymers LLC,
www.conventuspolymers.com

Two Scholarships to Students Specializing in Plastics Awarded

■ The Society of Plastics Engineers (SPE) Thermoforming Division has awarded scholarships to one undergraduate and one graduate student to support their continuing studies and active participation in plastics.

The students have been invited to attend the 28th SPE Thermoforming Conference®, which will take place September 20-22, 2021 in Grand Rapids, MI, at DeVos Place, the JW Marriott Grand Rapids and the Amway Grand Hotel. The SPE has awarded both students a trip to the conference which includes the full conference registration.

The scholarship recipients are:

Olivia Ferki, University of Massachusetts, Lowell: Olivia is a graduate student and research assistant, pursuing a M.S. in Plastics Engineering at the University of Massachusetts, Lowell. She is specializing in medical plastics design and manufacturing and hopes to pursue a career in medical polymer research. Her anticipated graduation date is May 2023.

Olivia graduated with a 4.0 GPA from Pennsylvania College of Technology with a B.S. in Plastics and Polymer Engineer-

Olivia Ferki



Isabella Gayoso



ing Technology and a minor in Mathematics in May 2021. During her time at Penn College, she was an active four-year member of the SPE student chapter and served as Secretary and Vice President (twice). She has also been a member of the Alpha Chi Honors Society since April 2019.

Isabella Gayoso, Penn State University: Isabella, from Moon Township, PA, is a rising junior at Penn State University. She is a double major in Mechanical and Aerospace Engineering with minors in Entrepreneurship and Innovation and IST for Aerospace Engineers.

During the Summer of 2020, Isabella worked as a Process and Quality Engineering Intern at Brentwood Industries, a thermoforming plastics company in Reading, PA. In Spring 2021, Isabella interned as a Build Reliability Intern at SpaceX in Hawthorne, CA. Isabella is interested in how thermoformed plastics can be used in aerospace applications and hopes to use her experiences to positively impact both industries.

During the school year, Isabella is actively involved in the Society of Women Engineers, Women in Engineering program orientation, Phi Sigma Rho (engineering sorority), Engineering Ambassadors, and undergraduate research.

“Education is central to all of our activities, from grants and scholarships to the Conference,” said Robert Browning, SPE Thermoforming Division Student Activities Committee Chair. “Supporting the educational endeavors of the next generation of plastics professionals is one of the most important responsibilities that we, as a board, undertake each year. Olivia and Isabella have impressive credentials with bright futures ahead of them.”

■ SPE Thermoforming Division
thermoformingdivision.com

Plastics Machinery Shipments – Typical Slower First Quarter but Poised for Growth

■ The Plastics Industry Association (PLASTICS) announced shipments of primary plastics machinery (injection molding and extrusion) in North America came in lower in First Quarter 2021 than Fourth Quarter 2020. Shipments decreased following three consecutive quarters of growth, according to statistics compiled and reported by PLASTIC’s Committee on Equipment Statistics (CES). The preliminary estimate of shipment value from reporting companies totaled \$334.9 million in First Quarter 2021, an 11.1% decrease from the previous quarter. However, compared to First Quarter 2020, plastics machinery shipments increased by a solid 31.9%. This was the third consecutive quarterly increase in plastics machinery shipments year-over-year.

“Plastics machinery shipments usually start slow every first quarter, so it was not surprising to see the data came in lower. This is

in sync with overall economic activity that is usually slow, starting every first quarter. Judging from a year-over-year comparison, plastics machinery shipments were actually off to a good start. With the economy staying in a recovery cycle, plastics machinery shipments can be expected to increase this year. However, supply chain issues in plastics end-markets could slow growth in plastics equipment demand, so we’ll be watching market dynamics very closely in the coming months,” said Perc Pineda, Ph.D., Chief Economist of PLASTICS.

Injection Molding vs Extruders

Although the value of shipments of injection molding equipment decreased by 11.1% in First Quarter 2021, it was 39.8% above First Quarter 2020. The value of shipments of single-screw

extruders fell 38.3% from Fourth Quarter 2020 and was 28.9% lower than First Quarter 2020. Shipments of twin-screw extruders, however, soared by 42.3% in First Quarter 2021 and rose by 18.3% over the same period in 2020.

Market Sentiment

PLASTIC's CES also conducts a quarterly survey of plastics machinery suppliers that asks about present market conditions and expectations for the future. In general, outlook among plastics machinery suppliers is very optimistic.

"The equipment sector of the plastics industry came out of 2020 strong. The much-improved trade outlook will be a positive for plastics equipment suppliers on top of what can be expected as another good year for plastics equipment demand," added Pineda.

In the coming quarter, 89.5% of respondents expect conditions to improve or hold steady compared to a year ago, lower than the 96.0% that felt similarly in the previous quarter. As for the

next 12 months, 93.0% of those surveyed expect market conditions to be steady-to-better. This is higher than the 89.8% in the Fourth Quarter 2020 survey.

Plastics machinery total exports in First Quarter 2021 increased by 9.4% to \$395.0 million over Fourth Quarter 2020. Imports fell by 3.5% to \$845.0 million, resulting in a \$450.0 million trade deficit, which was 12.6% lower than in Fourth Quarter 2020. The volume of merchandise trade is expected to increase this year as global economic conditions improve.

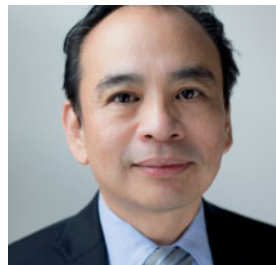

Perc Pineda, Ph.D., Chief Economist of PLASTICS

■ The Plastics Industry Association (PLASTICS)
plasticsindustry.org

Australian Representative Retained

■ Processing Technologies International (PTi), Aurora, IL announced the appointment of Plastic Machinery Works as its exclusive representative for PTi's extrusion systems and after-market sales and support in Australia and New Zealand. Plastic Machinery Works, located in Keilor Park, Australia now represents PTi in the sales and promotion of PTi's complete line of products, includes the SUPER-G® HighSPEED™ and HVTSE® DryerLESS™ extruders, and the G-SERIES® Configurable Roll Stands. In addition, Plastic Machinery Works will serve as the region's dedicated supplier of spare parts for PTi equipment.

PTi is recognized as a global leader for the supply of high-performance sheet extrusion machinery, with an emphasis on superior equipment performance and sheet quality. Product lines are comprised of single and twin-screw extruders, providing conventional, dryerless, and multi-resin extrusion capabilities for the production of mono, multi-layer, high barrier, foam, fiber and various other applications. Whether customized to exact production standards or chosen from a standard configuration within PTi's stock inventory program (Genesis), PTi sheet extrusion systems, including compounding and reclaim systems, provide solutions for a wide array of applications used in the

The SUPER-G HighSPEED SGHS3000-36D is a PTi extrusion system with high output capabilities, requiring a minimal footprint for operations, suitable for PS, PP and PET applications. It represents just one of the high quality extrusion lines that Plastic Machinery Works will assist PTi in bringing to the Australian and New Zealand markets



packaging, automotive, construction, food and beverage, and agricultural industries.

Plastic Machinery Works prides also itself on providing superior service and technical excellence, backed by a team of highly competent, factory trained engineers with decades of experience in the Australian and New Zealand manufacturing markets. Specialized services include machinery and control system installation and removal, repair and maintenance, diagnostic analysis and testing, as well as an inventory of readily available parts. Such services, along with Plastic Machinery Works ability to provide high-quality technical and hands-on support by experienced process engineers, aligns directly with the strategic goals and principles of PTi.

"This collaboration with Plastic Machinery Works defines the model for PTi to expand into strategic global markets, as this alliance provides the means for us to match the level of service and support currently experienced by domestic markets including Mexico and Canada," says Matthew Banach, PTi's Vice President of Business Development. With Australia's dependence on imports and the trends in sheet goods showing a rise, a regional presence provides a benefit that Australian extruded sheet producers would not otherwise have.

Leading the venture will be Plastic Machinery Works' Managing Director, Jeff Powers, and his team, who will work directly with Matthew Banach. "We are building an infrastructure to support the Australian sheet producers and thermoformers with this increasing demand for high quality domestic products," says Banach.

■ Processing Technologies International, LLC (PTi)
www.ptiextruders.com

Plastic Machinery Works, Pty Ltd.
www.pmw.com.au

Thermoformer of the Year Named

■ The award will be presented during SPE's Thermoforming Awards Dinner, held in conjunction with the 28th SPE Thermoforming Conference®. The conference will take place September 20-22, 2021 in Grand Rapids, MI, at DeVos Place, the JW Marriott Grand Rapids and the Amway Grand Hotel. The Awards Dinner will be held on Tuesday, September 21, at the JW Marriott Hotel.

As a young adult, Hal Gilham began his informal education by working at Productive Woods, his father's wood pattern shop. Gilham graduated from Lynchburg College with a degree in political science and for a short time he successfully entered corporate sales in the greater New York City area. However, motivated by the freedom and opportunity he saw in his father's small business, Hal joined the company and quickly made an impact by bringing in modern accounting, job costing, and business operations analysis. It wasn't long before more business came in, including thermoforming tooling. After working with a team reworking a fiberglass mold, Hal saw an opportunity and decided to expand the business into plastics processing. He purchased his first machine, and Productive Woods became Productive Plastics.

As the business grew with a steady flow of heavy gauge work, Gilham sought ways to expand his business, which included providing 'value added' services. By offering information on the materials, design, and the thermoforming process to his customers, Gilham expanded the business into more active markets. In the 1990s, the company continued to expand into other markets. Under Gilham's leadership, Productive Plastics increased its pressure forming capabilities and began serving the medical device industry, utilizing more heavily engineered materials that required specifications above the usual ABS or HDPE. As new technologies were used in 5 Axis CNC machining and tooling techniques with loose pieces, process improvement became

a core value and a catalyst for running the business. During this time Hal's father James, the founder of the company, retired and Hal gained complete control of Productive Plastics.

Toward the end of 2010, Productive Plastics conducted numerous projects where plastics purchases were equal to those in metal in cost, which was highly unusual for a small thermoformer.

A former SPE Thermoforming Division Board Member, Hal joined SPE in 1991 and is now an emeritus member of SPE. During his tenure on the Board, Gilham served as Chairman of the Materials Committee, the Processing Committee, the Machinery Committee and Parts Competition Chair at a few SPE Thermoforming Conferences. In addition, he served on the Division's Awards and Nominating Committees. Gilham is now retired but remains engaged in the industry where he spent most of his 40+ year career. His son, Evan Gilham, is now Chief Operating Officer of Productive Plastics.

"Hal Gilham's career is an inspiration to us all. From the next generation of plastics professionals to those who carry the entrepreneurial torch – in spirit or in practice – Hal's accomplishments motivate us all to think big," said Steve Zamprelli, SPE Thermoforming Division Chair. "The SPE Thermoforming Division Board is honored to name Hal Gilham as the 2021 SPE Thermoformer of the Year."

► SPE Thermoforming Division
thermoformingdivision.com



New Collaborative Innovation Center

■ Clariant announced a new collaborative innovation center to support North America's paints and coatings industry in meeting the challenges of emerging trends, increasing performance requirements, and meeting sustainability needs.

Clariant's new collaborative innovation center at Mount Holly West will focus on providing rapid solutions to paints and coatings' customers unmet needs and toughest challenges (Photos: Clariant)



Clariant's new state-of-the-art laboratory will bring together its research and technical experts in specialty formulation ingredients and additives to foster collaborative product development across all formulation aspects. Customers in the region will benefit from a unique level of R&D and application testing support. "Delivering industry-targeted, sustainable innovation to advance our customers' evolution is at Clariant's core. We are excited to expand our footprint in North America with an additional regional innovation center. It enhances our market proximity and ability to jointly develop solutions tailored to unmet needs, which will speed up our customers' time to market in offering differentiated products," said Gene Mueller, Head of Region North America at Clariant.

"There is so much more to modern paints and coatings than just color, they're incredibly complex," commented Andy Michael,

Technical Manager of Industrial Applications, BU Industrial & Consumer Specialties. "With our Additives colleagues alongside us in this new innovation center, we'll be able to take a more universal approach to solving these challenges, working on the best technology and multifunctional solutions to address customer needs."

The investment will strengthen R&D support for customers across the industrial space of paints, coatings, inks, adhesives and elastomers. Existing capabilities at the location, which includes research laboratories and a pilot plant currently used by the technical teams of Clariant Industrial and Consumer Specialties, will be upgraded and expanded with an additional 5000 sq feet of new laboratories and office space. New jobs will be created in the community as a result of the expansion.

The emphasis will be on innovating new ingredients, formulating, applying and testing. This includes on-site application testing capabilities, with the ability to test a paint formulation on performance, such as scrub, sag, levelling and color acceptance, with industry draw down methods. Further research will be performed in the areas of examining solutions for dispersing and wetting, emulsification, open time, durability and formulation optimization. New equipment has been included that will promote faster throughput screening, improved



Clariant's Mount Holly site

rheological testing, a spray booth and accelerated weathering chambers.

Construction of the new Mount Holly West Innovation Center is scheduled for completion in Q1 2022. Clariant's latest regional innovation center for North America follows the opening of the Consumer Care Innovation Center in New Providence, New Jersey in September 2019.

 Clariant
www.clariant.com/coatings

Vice President, Aftermarket Sales Promoted

■ Davis-Standard announced that Joe Guigli has been promoted to Vice President, Aftermarket Sales – North America. Joe will lead a dedicated team to advance customer service goals, field sales coverage, and improve market penetration throughout the United States and Canada.



Joe Guigli

Guigli brings more than 13 years of Davis-Standard experience to his position having held various leadership roles including regional sales manager, inside aftermarket sales, and product manager. He will build and manage an expanded aftermarket field sales team that will better serve Davis-Standard's broad customer base with dedicated personnel for each territory. In addition, Davis-Standard is seeking candidates for coverage in three new regions, which include the West, upper Midwest, and Northeast/Canada.

"Joe's aftermarket expertise and leadership of a dedicated team better positions us to provide resources and support to customers," said Zachary Ament, Executive Vice President of Davis-Standard. "North America continues to be a strong and growing market for us. Providing customers with aftermarket products that improve operational efficiency, application development, and other profitability-driven goals is essential.

Commercial Product Director Appointed

■ Jay Baxter has been appointed to Commercial Product Director – Liquid Coating. Baxter will be responsible for growing Davis-Standard's global business in liquid coating and will support strategic initiatives.



Jay Baxter

"We are pleased to have Jay's range of experience and knowledge as we expand our reach in liquid coating applications," said Danis Roy, Davis-Standard Vice President of Sales, Films and Flexible Packaging. "One of his first projects as a new process engineer was to purchase and install Davis-Standard feedscrews. He understands the paper and nonwovens market and Davis-Standard equipment capabilities, which will serve our customers well as they pursue quality, efficiency, and profitability."

Baxter has a bachelor's of science degree in chemical engineering and a master's in business administration. He has been a member of the National Air Filtration Association, Pressure Sensitive Tape Council (PSTC), European Adhesive Tape Association (AFERA), Federation of European Producers of Abrasives (FEPA), and is a founding member of the Healthcare Plastics Recycling Council.

 Davis-Standard, LLC
www.davis-standard.com

Complete Solutions in PVC-O Large Diameter Pipes for a Wide Variety of Applications



The choice of a certain pipe or material for pressurized water networks is conditioned by many factors, some technical and others economic. Among them are the low roughness of the material that will reduce the energy required to transport the water, its reliability and durability of the pipe, its behavior against transient phenomena that occur during the exploitation phase, the ease of installation, and of course its cost at the time of execution. The objective of TOM® PVC-O Pipes is to intelligently manage water resources. The pipes are subjected to stresses and tensions, both physical-mechanical and chemical and microbiological. These factors occur both in the soil and in the quality of the water they carry. The interaction of these factors is what determines the durability of an installation



Big diameter pipes

In water supply networks, large diameter pipes are traditionally used in materials such as steel, polyester (GRP), ductile iron and concrete, but there was no efficient solution that could combine the necessary charac-

teristics to comply with all the factors previously described. Water supply networks made of traditional materials currently register a leakage rate of up to 25 % of piped water. In addition, chemical deterioration means that

some pipes have to be replaced a few years after being installed. The need to expand the range in plastic solutions that combine and fully comply with these requirements for the durability of an installation, is what leads

NEXT LEVEL SOLUTIONS
Integrated Systems for Polymer Processing

Come and visit us at Fakuma in Friedrichshafen, Germany: October 12-16, 2021
HALL A6 | BOOTH 6202

maag.com

PUMP & FILTRATION SYSTEMS ›
PELLETIZING & PULVERIZING SYSTEMS ›
RECYCLING SYSTEMS ›
DIGITALIZATION ›

MAAG Group is the Partner for the Polymer Processing Industry worldwide. All of our integrated solutions from Pump and Filtration Systems to Pelletizing and Pulverizing systems to Recycling Systems have an outstanding performance for demanding customer requirements.

MAAG Group
a **DOVER** company



Molecor to develop a technological solution for the manufacture of TOM® PVC-O pipes up to diameter 1200 mm.

Technical, environmental and quality factors

TOM® PVC-O pipes have several advantages compared to other traditional materials, among which it is worth highlighting: their greater hydraulic capacity, allowing the transport of greater volumes of water for the same diameter; less load losses with improved energy costs; their better behavior against water hammer due to their lower speed; and their excellent impact resistance. TOM® pipes are the ones that provide the highest installation performance in meters/hour of assembly compared to other solutions, mainly due to their lightness and flexibility and their ease of connection. The tightness that

they provide to the system in the conduction prevents leakages, and therefore water losses, which would reduce the volume of water supplied.

The Molecular Orientation process provides TOM® Class 500 pipes with exceptional mechanical and hydraulic characteristics compared to pipes made with other materials available on the market. Applied to pressure pipes, a pipe of great mechanical and chemical resistance is achieved, therefore, with a very high useful life of more than 100 years. This characteristics provide solutions aimed at optimizing available water resources and reducing energy costs in hydraulic infrastructures.

In addition to this, TOM® PVC-O pipes are the most ecological solution of all that exist on the market for the transport of pressurized water, due to their best contribu-

tion to the correct sustainable development of the planet, as shown by different studies worldwide, among which we can highlight: Estimation of energy consumption and CO₂ emission associated with the production, use and final disposal of PVC, PEHD, PP, Foundry and Concrete pipes (Universitat Politècnica Catalunya) and the PVC-O Environmental study Product Declaration TEPPFA (The European Plastics Pipes and Fittings Association). TOM® PVC-O pipes present environmental advantages in all phases of their life cycle, extraction of raw materials, manufacturing and use, thus being the most efficient from the energy point of view.

In environmental matters, Molecor has obtained the Environmental Footprint seal from the Sustainable Life Foundation that calculates the environmental footprint of its TOM® pipes and

ecoFIT TOM® fittings in accordance with the Recommendation 179 / 2013CE proposed by the European Commission for the calculation of environmental footprints. It is thus proven that the environmental impact they show, not only in global warming, but in other environmental impacts such as the destruction of the ozone layer, is also lower than other materials. In this way, among the different environmental advantages that Oriented PVC presents in all phases of its life cycle we can find greater efficiency in terms of the use of natural resources.

Likewise, the quality of TOM® Pipes and ecoFIT TOM® PVC-O Fittings is evidenced by the AENOR N Mark recognition, which has granted the corresponding product certificates. TOM® PVC-O pipes have been certified according to the UNE-EN 17176 standard and ecoFIT TOM® PVC-O fittings according to the UNE-CEN/TS 17176-3: 2019 standard.

TOM® Pipes are certified in more than 10 countries, and have been awarded on different occasions for their high quality, efficiency, as well as for the technical innovation they have brought to the market. TOM® PVC-O pipes are also a product guaranteed for 50 years.

The choice of TOM® pipe: diameters and pressures

The projection of hydraulic networks is carried out worldwide and it is increasingly common for TOM® PVC-O pipe to be the material chosen for their execution, thanks to the wide range of advantages it offers for all the players involved in the sector, from the promoter to the end user.

The market shows great interest in Oriented PVC pipes as an alternative to traditional solutions, thus meeting the current needs for the application of plastic materials as an efficient alternative in large pressurized water pipelines, being the best technical and

economic proposal for network design.

The choice of the product to be used must be considered taking into account several parameters such as the durability of the installation, the hydraulic capacity, the ease of installation, the operational efficiency or the maintenance costs, all of them characteristics well covered by the TOM® pipes and ecoFIT TOM® fittings becoming the best solution for the transport of pressurized water.

Thanks to its exclusive Genuine Air System, Molecor produces Class 500 pipes and fittings in Oriented PVC, offering the market comprehensive solutions in PVC-O, highly effective, sustainable and with a long-life expectancy. With the development of technology for the manufacture of pipes up to DN1200 mm, PVC-O becomes part of the materials that can be used to undertake large-diameter works, offering the market the widest range of PVC-O pipes in a wide variety of nominal pressures.

Molecor is a pioneer in the manufacture of large diameters. The technology developed by the company made it possible to manufacture pipes with nominal diameters of DN500 mm, DN630 mm, DN710 mm and DN800 mm, non-existent in the world market for PVC-O pipes, and which have been turning points in the sector, since their manufacture was unthinkable until the appearance of the Molecor technology.

TOM® PVC-O pipes are manufactured in a wide range of nominal pressures (12.5, 16, 20 and 25 bar) and diameters (90 to 1200 mm), and ecoFIT TOM® PVC-O fittings are manufactured in PN16 bar and nominal diameters of 110, 160, 200, 250, 315 and 400 mm.

MOLECOR®
molecor.com/en



INSPECT MORE



Optical Inline Inspection of extruded products

Small-budget solutions

Surface. Geometry. All-In-One.

www.pixargus.com

Effective Process Optimisation in the Production of LDPE by Means of Online Quality Control

“Quality control has always been important to us. But we were not really aware at the beginning that we could also ensure a considerable process optimisation by means of the OP5. At first, the measuring device delivered results that seemed unreal to us. This was solely due to the fact that even several daily laboratory measurements could not adequately reflect the dynamic changes in production. These variations only became visible through the short measuring interval of the automated OP5 online measurement. The continuous quality control with the use of the OP5 allows us to optimise the production process at any time and at the same time to finally classify our batch material. The advantages such as the fully automated measurement, the considerable time savings through the reduction of transition times and the high reproducibility through the OCS equipment, in comparison to the manual ISO 1133 measurement, contribute to an effective process optimisation and reduction.” David Cerra González, Quality Coordinator at Transformadora de Etileno A.I.E. (TDE), Spain

OP5 Online Measurement at customer site TDE, Spain



Plastics are produced in countless variants today. The most common is polyethylene. Modern processes mean that there are also different variations of this material today. Low-density polyethylene, or LDPE, produced using a high-pressure process, is one of them.

Transformadora de Etileno A.I.E. (TDE) has three plants for the production of low density polyethylene (LDPE)

Online MVR Measurement with OP5 vs. Manual.

Note: If the MFR value changes dynamically in production, small time intervals between the sampling of OP5 and laboratory measurement are sufficient to result high differences. The high fluctuations are now shown by the high measuring rate of the online measurement of the OP5. (© OCS)

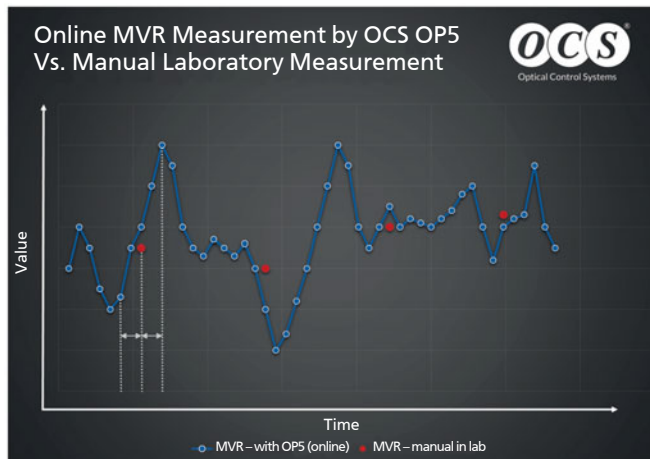

in Spain. The annual capacity of LDPE is approximately 160,000 t/year. TDE focuses on continuous quality control and assurance in the ongoing production process in order to detect and optimise dynamic production fluctuations at an early stage and in a relatively short sequence. For this reason, two OP5 measuring systems are already in use in two of three production lines. Various deviations in production have an impact on viscosity and can therefore be monitored by online viscosity measurement using OP5. The continuous measurement of the Melt Index (MI) of polymer samples also allows a final classification of the batch material.

Save time and reduce costs: Due to the continuous measurement, real-time results can be visualised in 5 to 10 minutes via the touch panel with a data trend in 24/7 operation. This leads to considerable time savings compared to a manual ISO 1133 measurement. The permanent data logging makes it possible to intervene significantly in the production process and save costs.

High reproducibility through OP-MFR measurement: The OP5 MFR measurement is a method carried out by means of exact control of the melt flow in combination with a high-precision and self-developed melt pressure measurement. This method achieves a typical reproducibility of +/- 1 % in comparison to the manual ISO 1133 measurement with +/- 5-10 % deviation.

OCS Optical Control Systems GmbH
www.ocsgmbh.com

2021

7th International Conference

RePlast



«Modern plastic recycling technologies»

21-22 September, Moscow
Registration opens at 10:00

Topics for discussion

- ▶ material sorting and selection automation
- ▶ metal detectors
- ▶ crushers and shredders
- ▶ washing equipment
- ▶ water treatment and closed loop water purification systems
- ▶ agglomerators and plastic compactors
- ▶ melt filters of various designs and filter changers
- ▶ recycling extrusion lines
- ▶ inline recycling into finished products
- ▶ compounding of secondary polymers
- ▶ PET crystallinity enhancers
- ▶ peripheral and auxiliary equipment
- ▶ special-purpose additives and fillers
- ▶ quality control of material and end products
- ▶ choosing laboratory equipment
- ▶ designing products suitable for recycling

Contacts

Learn more



Alla Kravets

+49 2233 949 87 93
a.kravets@vm-verlag.com

Bella Eidlin

+49 152 299 07 895
b.eidlin@vm-verlag.com

Olga Kirchner

+49 152 056 26 122
o.kirchner@vm-verlag.com

Martina Lerner

+49 62 26 97 15 15
lerner-media@t-online.de

High Performance and Quality for White Goods

Multi-Touch roll stack



Originally developed for high-tech applications, it now also conquers standard segments: the multi-touch roll stack for sheet and board production from battenfeld-cincinnati Germany GmbH based in Bad Oeynhausen. In fact, the roll stack creates ideal cooling conditions thanks to its special process technology concept, and thus delivers high-quality semi-finished products, and all of this with narrow thickness tolerances and high line speeds, too. After the sheet industry, more and more board production customers now also rely on the modern roll stack. One of these is the Turkish Vestel A.S. Group headquartered in Manisa, which recently purchased a complete 2-layer line for Vestel Home Appliances Refrigerator Factories to produce HIPS boards. In addition to the multi-touch roll stack, the core competencies of this line include three high-speed extruders, which provide its enormous output of up to 3,000 kg/h

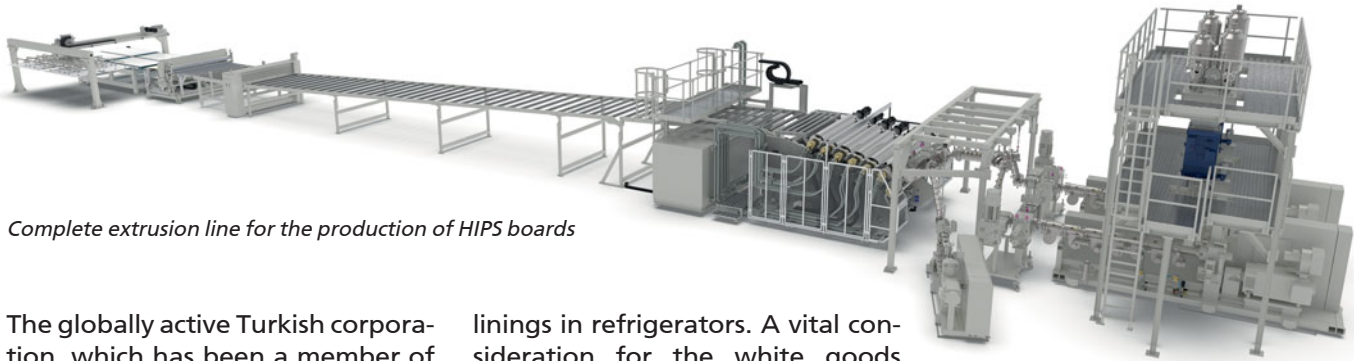

Complete extrusion line for the production of HIPS boards

The globally active Turkish corporation, which has been a member of the Zorlu Group since 1994, consists of 28 different companies and serves industries such as makers of consumer electronics, household appliances, mobile technology and LED lighting. The companies united under the roof of the Group include famous brands such as Telefunken, Graetz, Techwood, Finlux, Luxor and Vestfrost, as well as Hitachi, JVC and Toshiba. Vestel is the export champion of Turkey for 22 years in the electronics and home appliances industries through its exportation to 156 countries with a diversified product range based on technology and design development competency.

For its plant in Manisa/Turkey, Vestel Home Appliances, who can already look back on a long-standing business partnership with the German machine manufacturer battenfeld-cincinnati, most recently purchased a complete line to make HIPS sheet for door and interior compartment

linings in refrigerators. A vital consideration for the white goods manufacturer was to have a powerful line with a high performance in terms of sheet quality. This is why the modern extrusion line with its 75-40 T6.1 and 45-32 T2.1 high-speed extruders and multi-touch roll stack was chosen.

High-speed extruders from Bad Oeynhausen come with a very compact design and yield an enormous output with their high screw speeds of up to 1,500 rev/min. The melt's residence time inside the extruder is long enough to achieve optimal homogenization on the one hand, and on the other hand short enough to prevent mechanical or thermal damage to the material. At Vestel Home Appliances' Refrigerator Factories in Manisa, two size-75 high-speed extruders take care of plasticizing the core layer of the boards, which are up to 6 mm thick and up to 1,200 mm wide, while a co-extruder applies the glossy surface layer. From the

extruders, the perfectly processed melt passes through a flat-sheet die into the multi-touch roll stack with 2,400-mm-wide rolls. Thanks to a combination of a two-roll stack for pre-calibration with several re-calibration rolls, which ensure even surface contact with the rolls, it produces excellent semi-finished product attributes, that is, optimal flatness with narrow thickness tolerances. While the excellent flatness is important for further processing of the boards by thermoforming, the reduction of thickness tolerances means hard cash. With the modern line, Vestel has been able to reduce the thickness tolerance of its HIPS sheets by some 50 % compared to its existing lines equipped with conventional three-roll roll stacks. With a line output of 3,000 kg/h, this alone yields annual cost savings in six-digit euro figures.

The overall concept, with its ecological as well as economic advantages due to reduced raw material consumption, has already been favored by several other customers. For example, battenfeld-cincinnati recently installed a comparable ultra-modern sheet line for a German customer at its production plant in Poland. The specialty in this case is that the thickness range of the semi-finished products being made can vary from 1 to 6 mm, and a winder for sheet up to 2 mm thickness as well as a stacker for thicker boards are integrated.

Co-extrusion set up of the board line at the entrance of the Multi-Touch roll stack



battenfeld-cincinnati Germany GmbH
 (Bad Oeynhausen, Germany)
www.battenfeld-cincinnati.com

Picture 1. MAS cascade extrusion line for film recycling (Picture: MAS)

Since 2013, Austrian extrusion and recycling technology company MAS-Maschinen- und Anlagenbau Schulz GmbH and Dutch film recycling company Caroda BV have been cooperating in the technological development of film recycling systems. These systems focus on LDPE industrial films, with a higher LLDPE content, as well as agricultural films

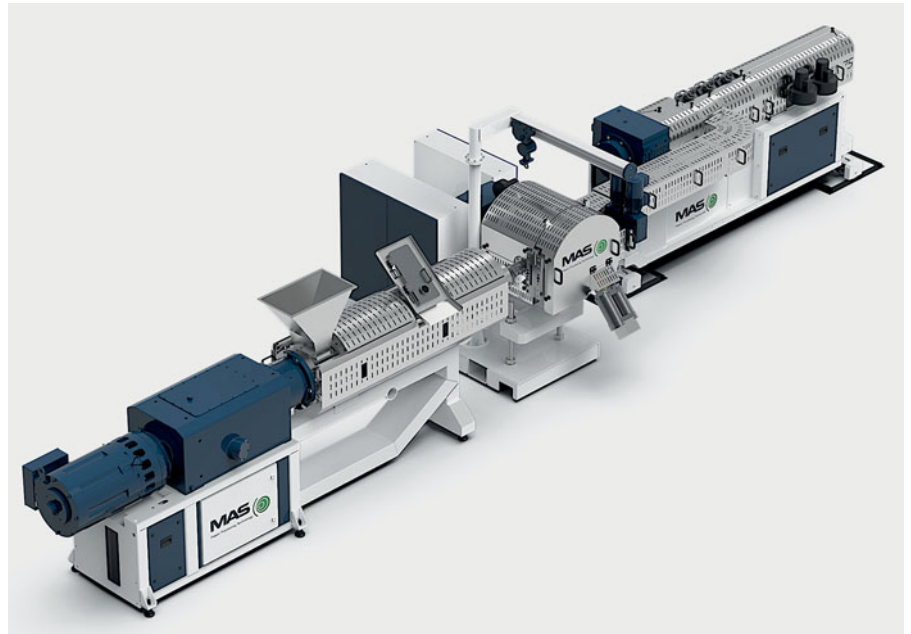

Awarded for New Process Technology in Regranulating LDPE / LLDPE Waste Films

The MAS components used for this include the DRD (Double Rotary Disc) film flake cleaning system and a downstream extrusion system. The latter consists of

the MAS-specific co-rotating conical twin-screw extruder, a continuous MAS melt filter and a single-screw degassing cascade (Picture 1).

Picture 2. MAS authorized signatory and sales manager Ing. Stefan Lehner demonstrates the significantly improved quality properties of the LDPE/LLDPE recycling film developed jointly with Caroda (Picture: MAS)



Picture 3. The trophy for the category "Recycling Machinery Innovation Awards 2020" went to MAS-Austria, Stefan Lehner (left) and the managing partner of Caroda BV, Peter Daalder (right) (Picture: Caroda BV)



Incorporated special features of the DRD dry cleaner include elements that completely dispense with the use of water as a washing medium operating via the principle of an air cyclone. In it, film flakes are dried by friction in a heated air vortex. In the process, adhering contaminants such as sand, dust and soil are separated and discharged by centrifugal forces. The advantage of waterless operation includes lower energy input for the cleaning process, resulting in a significantly smaller CO₂-footprint.

For subsequent extrusion, the MAS twin-screw extruder is also well suited to low-bulk-density feed materials thanks to its conceptually large feed opening. Due to modular, co-rotating screws and short processing length, plasticizing is designed to be mechanically efficient and simultaneously as gentle as possible.

A key goal of the joint development work was to increase the surface quality and thus, the printability of the film by minimizing the specks (dust and dirt particles, as well as cross-linked polymer agglomerations) still contained in the recycling film.

The functional principle of the MAS extruder are the keys to its success

The basis of this system is a co-rotating MAS twin-screw extruder designed to optimize the entire extrusion process. The short and gentle melting phase in the MAS extruder reduces the formation of polymer cross-links to a minimum. A screw geometry developed directly for processing LDPE films with an increased LLDPE content, together with an adjustable screw speed, enables the shear forces required for ultra-fine homogenization to be applied with pinpoint accuracy. With this, the foreign bodies contained in the melt, as well as already existing cross-linkages, are broken up, crushed and evenly incorporated. This significantly minimizes the effect of specks on the smoothness and optical properties of the film. This results in substan-

Picture 4: From Caroda B.V. with the MAS equipment recycling goods (Picture: Caroda BV)



Picture 5: Recycling-Technology-Award (Picture: MAS)



tially improved printability of the film, a significant improvement in the print image and a reduction in the amount of ink required (Picture 2).

Process technology honored with "Plastics Recycling Award 2020"

This process technology, developed by MAS and Caroda BV, received an award at the "Plastics Recycling Awards Europe 2020". During this event, which traditionally takes place in Amsterdam, both companies were awarded the main prize in the category "Recycling Machinery Innovation" (Picture 3).

Summary

Through cooperation between plant manufacturer and plant operator, MAS and Caroda BV have developed a process technology that significantly increases the surface quality of recycled films. It consists of the MAS conical twin-screw extruder, efficient melt filtration and optimum melt degassing in the downstream extrusion cascade. In a circular economy, this opens up significantly expanded application possibilities for recycling films.

Author:
Reinhard Bauer – TECHNOKOMM
office@technokomm.at

iProfilControl: Efficiency where it's really essential. The iProfilControl system uses the same proven inspection technology as its bigger brother, ProfilControl 7, but is much smaller in size. This makes the integration of the system into production lines even more convenient

Measuring technology specialist PIXARGUS is notable especially as a supplier of high-end solutions for technologically challenging quality inspection tasks. Now, PIXARGUS is setting a strong foot also in the lower-budget segment. The magic word here is: downsizing. Head of Sales, Michael Frohn, summarizes: "We offer high performance at an affordable price."



Affordable and Ready to Start in Virtually no Time – New Downsized Systems

The new downsized systems have become available just at the right time. The plastics industry, like many other sectors, has been feeling the impact of the COVID-19 pandemic for more than a year, with markets becoming increasingly hesitant. Now, flexible and efficient solutions are needed – solutions that achieve maximum ef-

iProfilControl inspects the geometry and surface of simple and even highly complex profiles in a matter of seconds. The hinged arrangement of the sensor head guarantees that the measurement is not influenced by any parasitic light effects

fects on your production while sparing low budgets. This is where the smart inspection systems AllRoundia DualVision (DV) for round products and iProfilControl for profiles come in.

While being very compact, these new PIXARGUS systems are able to adjust themselves – virtually without operator intervention – to the inspection task on hand. The systems have been designed to be ready to start with only minimum set-up effort in any production environment. They can be easily integrated into a line and swiftly switched between lines, thanks to the minimum resetting effort required – two benefits which we placed special emphasis on in the design of the systems. The technology is based on that of their bigger brother, ProfilControl 7, which scores with its innovative LED and sensor technology and its unique multi-area functionality. PIXARGUS promises high performance at an affordable price. AllRoundia DV, for example, is available from only 20,000 Euros.

Even today, PIXARGUS designs its inspection systems with a view to intuitive user-friendliness and easy digital



Smaller in size, more flexibility, and ready to start in almost no time: AllRoundia DualVision from PIXARGUS – the first ever system performing complete 360° contour measurements and surface inspection of round product in a single unit

networkability within the production process. But this is no reason for the PIXARGUS team to rest on their laurels. "Our goal is Plug & Play", adds Michael Frohn. He holds out the prospect that, not too far into the future, their systems will be able to be commissioned without the support of a technician.

PIXARGUS GmbH
Industriepark Aachener Kreuz
Monnetstr. 2, 52146 Würselen, Germany
www.pixargus.de



EXTRUSION

EXPERT MAGAZINE ON PLASTICS EXTRUSION

The only technical magazine worldwide exclusively for the sectors:

- Material Preparation
- Compounding
- Extrusion
- Recycling
- Calendering
- Thermoforming
- Welding
- Finishing of Plastics and Elastomers



Extrusion (German)

Extrusion International (English)

Extrusion International USA (English)

Extrusion Russia Edition (Russian)

Extrusion Asia Edition (Mandarin/English)

The only plastics trade magazine for Asia, published from Germany

8 issues a year

6 issues a year

6 issues a year

4 issues a year

2 issues a year

**SMART
EXTRUSION**

All editions available for free:
www.smart-extrusion.com

VVA Verlag GmbH Cologne/Germany



The PVC industry depends on a secure supply of additives to enable uninterrupted production of all extruded, injection molded or calendered articles. The shortage of one single raw material can disrupt the production process, and even cause a complete breakdown if there is no alternative available. In recent years, the production of typically used castor-derived lubricants has become increasingly dependent on the supply from India. To provide more readily available lubricants that are independent of castor as a feedstock but provide similar performance benefits, Emery Oleochemicals, a global specialty chemicals manufacturer, has developed effective bio-based alternatives



Castor plant

Alternatives to Castor-Derived Lubricants for PVC Processing

Overview of Natural-Based Polymer Additives

The Green Polymer Additives business unit of Emery Oleochemicals is highly experienced in development,

Emery Oleochemicals' lubricants are also available as dust-free beads



application and global production and supply of polymer additives including lubricants for the PVC industry. Under the brand LOXIOL®, these products support the company's mission to be the first choice in sustainable polymer additives. In addition to the sustainability objective of using bio-based raw materials to the best possible extent and providing technically superior products, security of supply is also a key pillar of the Green Polymer Additives business success.

Castor-derived Lubricants in Rigid PVC Extrusion of Profiles and Pipes

Hydrogenated castor oil (HCO) is a typical internal lubricant for PVC, so it is used to reduce friction between polymer chains. This results in decreased melt viscosity of the PVC and improved flow. HCO is ei-

ther used as a single lubricant, or as a component of lubricant packages or of stabilizer one-packs.

12-Hydroxystearic acid (12-HSA) is mainly used to disperse inorganic fillers, predominantly chalk, in the PVC matrix. It is made by saponification of HCO. 12-HSA is sometimes called the "anti-plate-out additive" because of its unique dispersion properties.

The only source on industrial scale for both HCO and 12-HSA is castor oil and the largest producer of castor oil is the country of India.

Castor Supply Dominated by One Region

The green line in Figure 1 shows the global castor oil seed production volume from 2005 to 2019. The number peaked in 2011, and since then to the year 2019, production

Emery Oleochemicals' lubricants suitable for various PVC applications



has decreased by almost 50%; indicating castor's reduction in availability. The green dotted line in the diagram represents the production solely in India where the vast majority of the world's castor oil seed comes from.

As a consequence, the Indian market share (blue line) increased to 85 to 90% in the last several years. Therefore, a shrinking world castor oil seed market is highly dependent on the Indian harvest and supply.

Challenges in Global Logistics

The shortages of raw materials caused by the March 2021 blockage of the Suez Canal demonstrated that such quasi-single sourcing can lead to serious supply issues and can bring entire production chains to a standstill on short-term notice. Extreme increases of freight rates and COVID-19 related obstacles in logistics, as observed in 2021, lead to a significant level of uncertainty in the security of supply.

Viable Alternatives to Castor-based Products

Emery Oleochemicals has developed suitable alternatives to castor-based lubricants. The company's natural-based alternative PVC lubricants mimic the performance of HCO or 12-HSA but are independent from castor as feedstock. Emery's products are manufactured from raw materials produced in all major regions avoiding long and sensitive transportation routes. Emery Oleochemicals' offers a broad portfolio of internal lubricants that are viable substitutes for HCO and that can meet a variety of application requirements. As an alternative to 12-HSA, Emery's new product innovation called LOXIOL® G 19 can be utilized to replace the castor-based product. Alternatives are also available from Emery that comply with FDA and EU 10/2011 regulations for indirect food contact.

Figure 1: World's and India's castor oil seed production in the last 15 years from 2005 to 2019 [data from the Food and Agriculture Organization of the United Nations, <http://www.fao.org/faostat/en/#data/QC/visualize>]

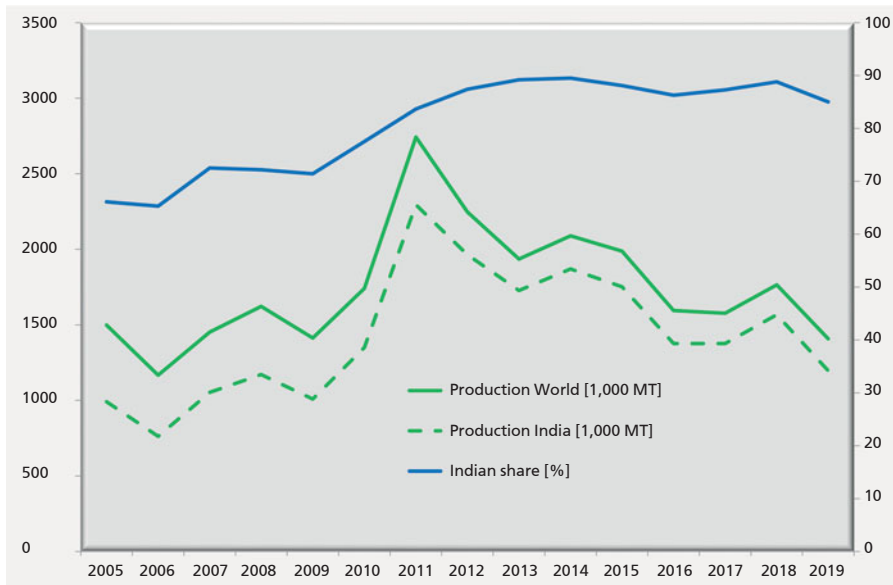

Emery Oleochemicals GmbH
 Paul-Thomas-Straße 56, 40599 Düsseldorf,
 Germany
[greenpolymeradditives.emeryoleo.com/
 /additives](http://greenpolymeradditives.emeryoleo.com/additives)

Biopolymer Extrusion Coating with „Edge Encapsulation“ Increases Line Speed and Reduces Coat

Schematic above, with upper die and feedblock halves removed, shows encapsulation achieved with Nordson feedblock insert (circled); schematics below show a new EDI® EPC™ die, with encapsulating polymer introduced in the die rather than in the feedblock

Technologies developed by SAM North America and Nordson Corporation have made it possible to increase throughput and reduce coat weight in the extrusion coating of biopolymers such as PLA by encapsulating the edges of the coating with LDPE

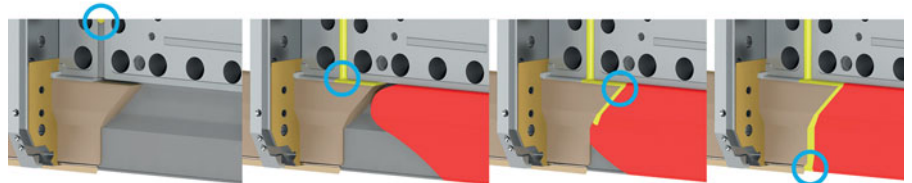
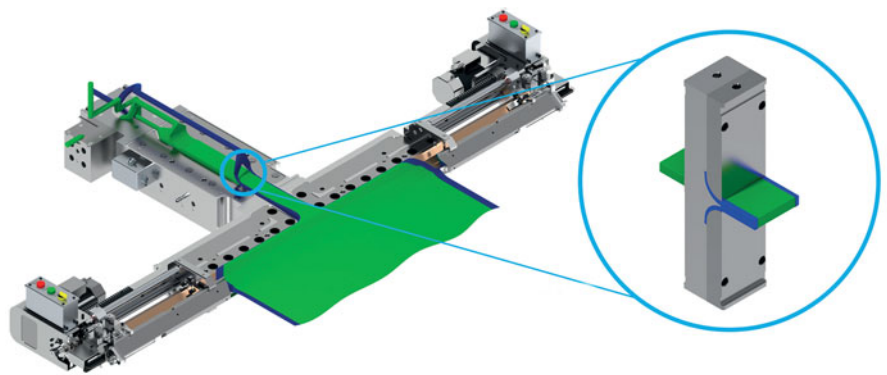

While conventional coextrusion yields two or more materials in horizontal layers, special encapsulating inserts developed by Nordson for its coextrusion feedblock make it possible to extrude additional material along either edge of this horizontal structure. Using this technique, SAM North America has found that encapsulating a PLA coextrusion with edges of LDPE makes it possible to offset deficiencies of PLA – in particular its low melt strength – that have limited its melt curtain stability, draw-down ratio, line speed, and coat weight.

“Using LDPE edge encapsulation on our pilot line, we have achieved line speeds in excess of 1200 fpm [366 mpm] with PLA, as against less than 600 fpm [183 mpm] with PLA alone,” said Ed Lincoln, V.P. Extrusion Sales

of SAM North America. “We have seen coat weight reduced from 16 gsm to less than 10 gsm.”

The high melt strength of LDPE has helped make this polymer by far the most widely used in extrusion coating. “For processors wishing to replace some portion of their LDPE usage with biopolymers, a main obstacle has been that their lower melt strength causes extreme neck-in and edge instability at desirable line speeds,” said Sam Iuliano, Chief Technologist for Nordson’s EDI® extrusion die and feedblock business. “By introducing a higher-melt strength material on each edge of the melt curtain, edge encapsulation minimizes the processing limitations posed by many biopolymers.”

Neck-in is the tendency of the polymer web to become narrower as tension is applied when it exits the die. The result is

SAM North America coextrusion coating and laminating laboratory handles web widths up to 36 in. (914 mm), from flexibles to board, pre-treated with corona, primer, flame or ozone



a build-up of material along the edges of the web, or “edge bead,” that must subsequently be trimmed away as scrap. To ensure that this edge bead consists of the lowest-cost polymer in the coextruded structure, Nordson has developed customizable feedback inserts that introduce flow of the low-cost polymer only at the edges of the structure. The combined materials are then distributed to the final target width in the flow channel or manifold of the die.

While the encapsulation inserts can be readily retrofitted into existing EDI feedbacks, Nordson offers new EDI dies equipped with the EPC™ deckle system, which can be adjusted to reduce edge bead formation, and a melt flow system in which the edge encapsulation polymer is introduced in the die rather than in the feedback. The port for introducing the encapsulation polymer moves in concert with the deckle mechanism. “By introducing the encapsulation polymer at this point in the process, the interface between it and the core structure is more defined and the transition overlap between

the encapsulation material and the biopolymer material is reduced,” said Iuliano. “The die limits the formation of edge bead and reduces the amount of edge trim.”

SAM North America has also developed coextrusion techniques for encapsulating biopolymer structures with LDPE that permit rapid change-over between conventional and biopolymer coatings. The technology addresses the wide differences in processing properties between the two materials. Andy Christie, managing director of SAM North America, will introduce the technology at the Extrusion 2021 Conference, September 21 – 23 at the Donald E. Stephens Convention Center, Rosemont, IL.

■ SAM North America, LLC
www.sam-na.com

Nordson Polymer Processing Systems
www.nordsonpolymerprocessing.com

SMART EXTRUSION

A SPECIALIZED WEB PORTAL

- ▶ News about relevant products and events
- ▶ Detailed reviews of various smart technologies
- ▶ Case studies from processors
- ▶ English, German, Russian and Chinese

- ▶ Video clips demonstrating smart equipment in live action
- ▶ Latest magazines available for reading and downloading
- ▶ Weekly e-mail newsletters

www.smart-extrusion.com

Industry 4.0 Makes Thermoforming More Effective

ILLIG Maschinenbau introduces "ILLIG Assist", a digital service platform to actively support ILLIG customers on the way to Industry 4.0. Digital transformation is increasingly becoming a reality thanks to breakthrough technologies. This also applies to the packaging industry: manufacturing processes are becoming more digital and the entire value chain is being networked

Digitalization is here. IIoT (Industrial Internet of Things) and connectivity are increasingly important for manufacturing and industrial networking with production systems such as Manufacturing Execution Systems, MES. In particular, self-describing standard interfaces are becoming important to reduce customizing efforts and improve data access.

Learning system complements machine intelligence

ILLIG systems have long been equipped with the Intelligent Control Concept (ILLIG IC). Including calculation of machine parameters, a guided setup systems, and dynamic optimization. In addition, thermoforming systems can connect to local networks and databases to query production-related data. ILLIG Assist complements these digital systems and helps the machine operator as a learning component to cope with occurring events in the daily workflow. In the past, companies relied on notes and the "tribal knowledge" of experienced individuals. The new application simplifies knowledge transfer

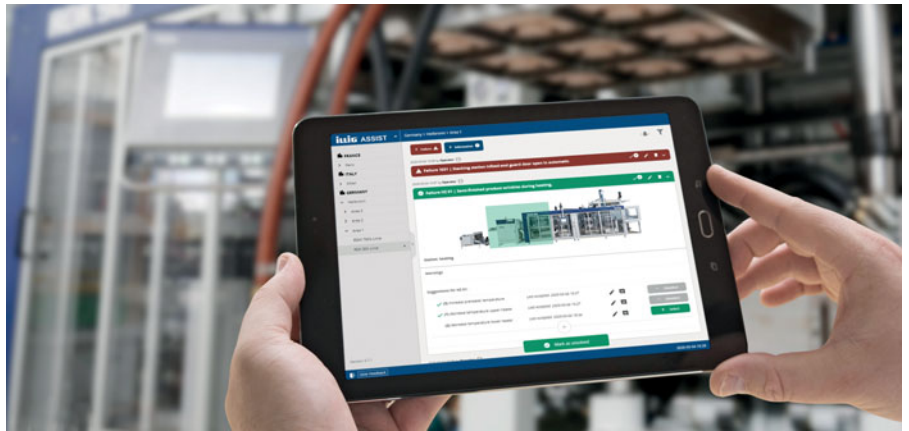

Digital service platform: ILLIG Assist supports customers on their way to Industry 4.0 (Picture: ILLIG)

through a clear and interactive graphic user interface.

Creation of a knowledge database

Messages from both connected machines and machine operators themselves are recorded and displayed chronologically. The system automatically provides a visual localization of events and offers detailed suggestions based on a solution database, initially populated by ILLIG's deep global expertise. Furthermore, operators can actively contribute their own suggestions and enrich them with videos and images. An integrated comment function allows users to comment on and evaluate proposed solutions. Users can also view and manage shift reports, maintenance information, and digital manuals. This approach serves to build up a permanent knowledge database, prevents the loss of knowledge due to the departure of experienced machine operators, and accelerates training for new employees.

IIoT platform as a basis for connectivity

ILLIG Assist is based on the IIoT platform ADAMOS and is expandable through a modular architecture of microservices that enable connections to external systems. Events reported to ILLIG Assist can be displayed using any internet-enabled communication ter-

minal and operators can be remotely informed. Event notifications are made by the operator or, in future versions, directly by the machine in the case of networked machines connected to the IIoT platform. Messages are automatically made available to other approved users inside the organization. In addition to asset management and chat function per machine, ILLIG Assist also provides rights management for creating and reading comments and other information. Depending on the user's rights, the system offers insight into the machine with its functional sub-blocks as well as an overview of the entire line, factory, or worldwide locations. ILLIG Assist has been developed together with customers, for machine operators and production managers, with the aim of increasing efficiencies in production, service, and maintenance through an intelligent communication tool and active knowledge management system. With digitalization, ILLIG brings customers even closer to their process, delivering higher added value.

Note: Terms marked with ® are registered and protected trademarks of ILLIG Maschinenbau GmbH & Co. KG

ILLIG Maschinenbau GmbH & Co. KG
Robert-Bosch-Str. 10, 74081 Heilbronn,
Germany
www.illig.com

SMART EXTRUSION

**THE SPECIALIZED WEBPORTAL
ON EXTRUSION
FOR EVERY MODERN NEED**



VM Verlag GmbH
Cologne, Germany

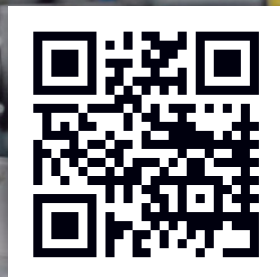

www.smart-extrusion.com



Web conference

December 8, 2021 • Start: 10.00 CET

lab.extrusion-info.com

The official language
of the conference is English

Laboratory & quality control in plastics processing

- laboratory equipment
- quality control of input raw materials
- quality control of finished products
- analytical equipment
- measuring equipment
- pilot and test lines
- desktop mini IMM and mini extruders
- laboratory mixers and compounders
- laboratory and processing simulation software
- metrology and equipment verification
- laboratory analysis services
- formulation development services
- certification services
- external engineering and research services
- R&D in the enterprise

Developed by:

VM VERLAG
Cologne/Germany

EXTRUSION

EXTRUSION
INTERNATIONAL
WORLDWIDE

ЭКСТРУЗИЯ
EXTRUSION RUSSIAN EDITION

挤塑 EXTRUSION
ASIA EDITION

smart.molding
international



Contact: Alla Kravets • Tel.: +49 2233 949 87 93 • a.kravets@vm-verlag.com