

02/2024

VM VERLAG
Cologne /Germany

EXTRUSION INTERNATIONAL



Guill

WORLD LEADER IN EXTRUSION TOOLING

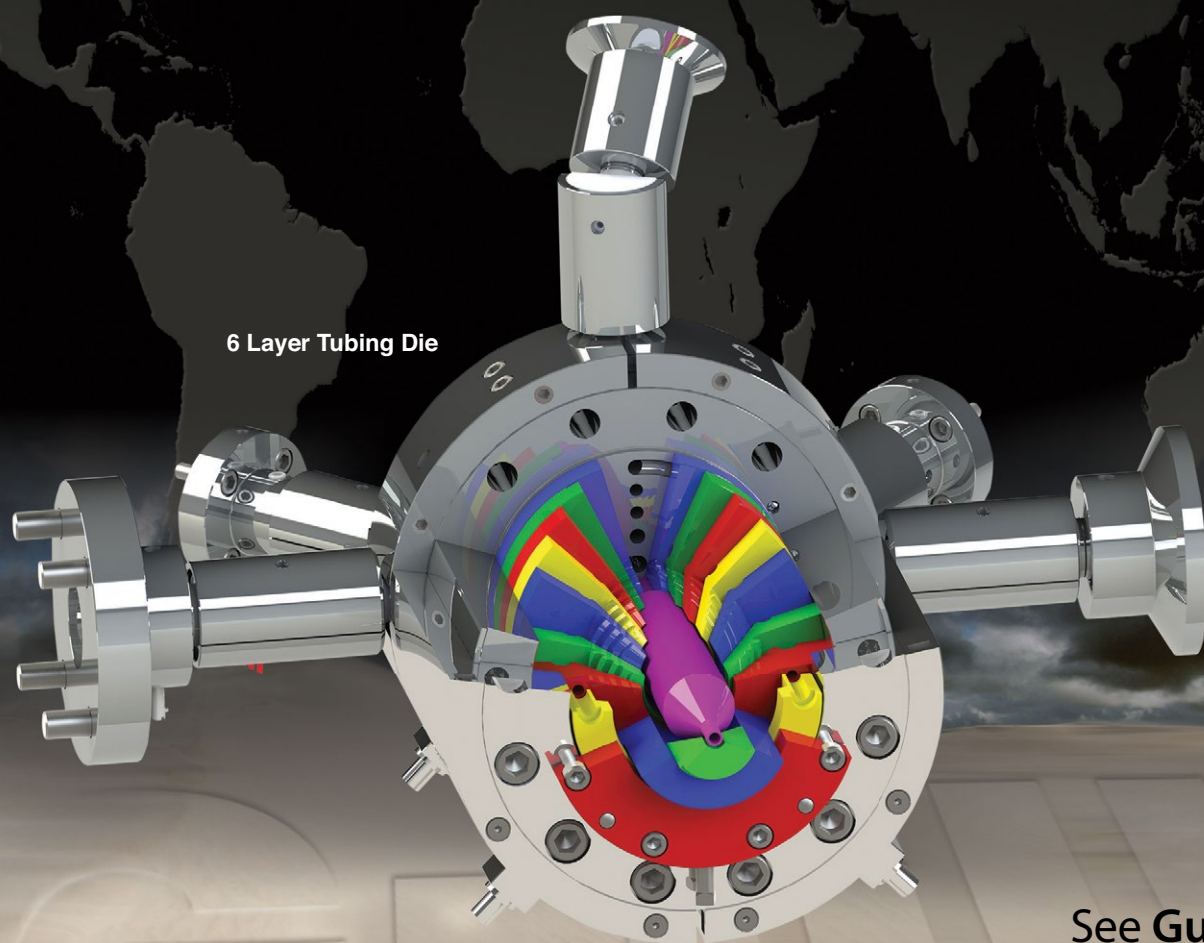

6 Layer Tubing Die

www.guill.com

See Guill at
NPE 2024
The Plastics Show
Booth W7051

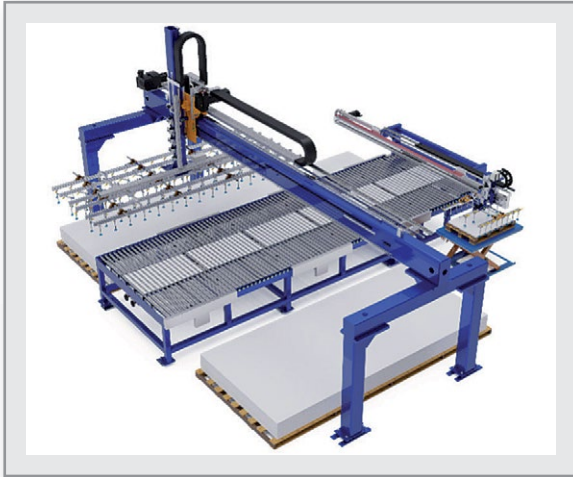
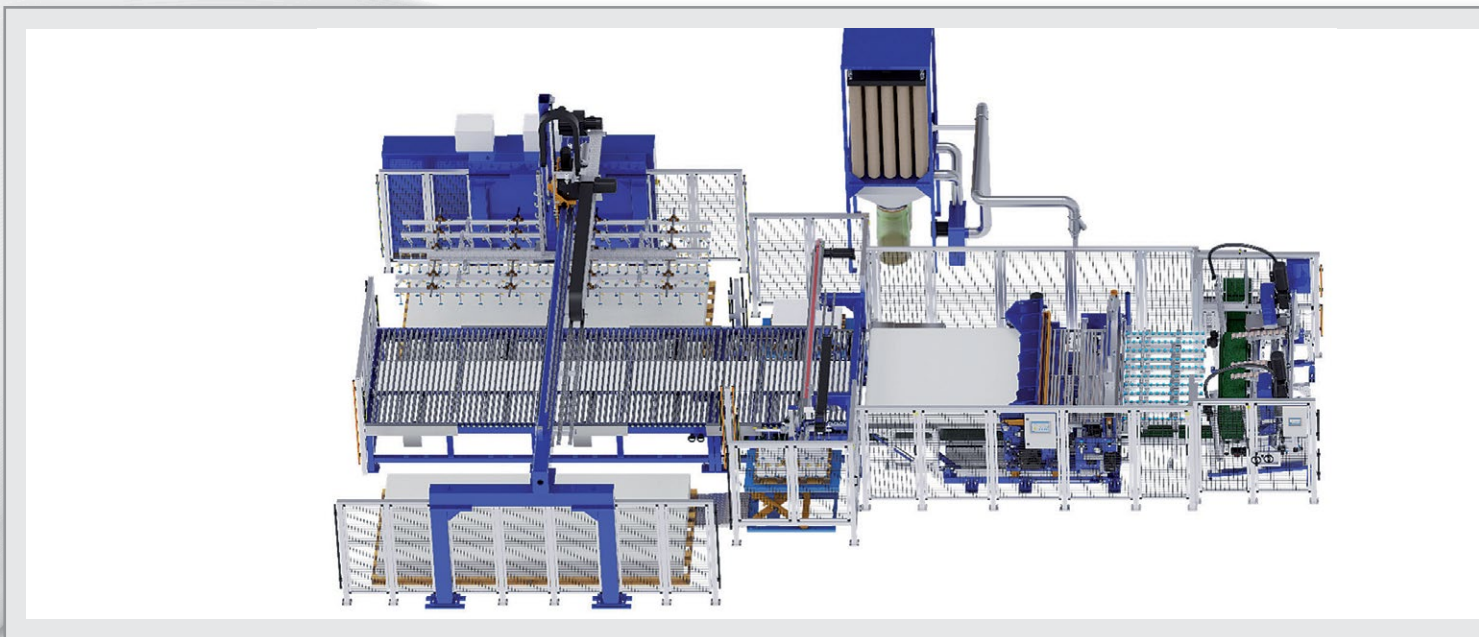

Plate Stacking Machine

for automatic depositing of your production plates on transport pallets or trolleys.

Optional available with:

- Additional stacking places
- Spreading device of sheets side by side
- Separation of consecutive panels for simultaneous stacking



Cross Cutting Combination

enables optional sawing or cutting in one machine.

Optional available with:

- Hydraulic driven scissor
- Electric driven scissor
- Cross Cut Mill instead of saw
- Cutting angle adjustment



Made in
Germany

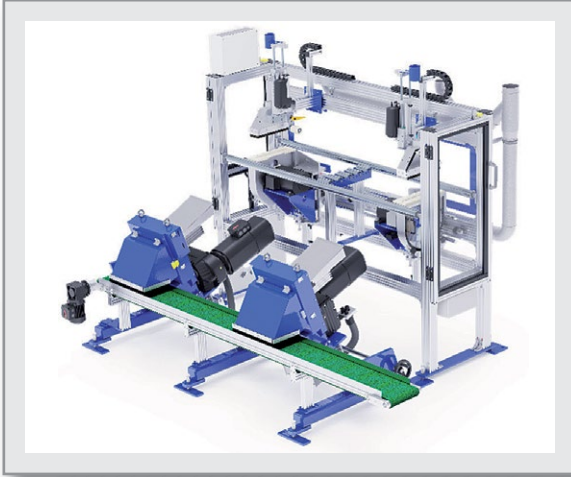

Edge Trimming Saw & Trim Strip Chopper

an unbeatable team for longitudinal cutting of your panel and direct shredding of the resulting return material.

The machines are also offered individually with many options.

As a specialist in the field of special machine construction, we always find a solution!



Pull Off Roller

provides precise regulation and compliance of roller speed and roller force.

Optional available with:

- Automatic material run control
- Selection of roller coatings
- Multiple Pull Off Roller version

Calender

for continuous dimensional accuracy and surface quality.

Key data:

- Throughput capacity depending on material 400 - 1300 kg/h
- Line speed 0,5 - 70 m/min
- Line pressure per roller: 100-1300 N/cm



STEIN Maschinenbau GmbH & Co. KG

Wartbachstrasse 9
66999 Hinterweidenthal/Germany
Tel. (+49) (0)63 96-9215-0
Fax (+49) (0)63 96-9215-25
stein@stein-maschinenbau.de
www.stein-maschinenbau.de

CONTENTS

Firms in this issue	6	Twin Screw Extrusion Equipment for Compounding,	
Imprint	7	Reactive Extrusion, Devolatilization, Foaming	
Industry News	8	and Direct Extrusion on Display at NPE2024	33
Calendar	8	Various Solutions for Mixing, Foaming	
Fakuma 2024	8	and Cooling for the Plastics Industry	34
Gold Sustainability Rating by EcoVadis Maintained	9	„Materializing Ideas“ – The Latest Advancements	
European Plastics Industry	10	in Plastic Materials for the Fast and Economic	
Stronger Worldwide in the Industrial		Realization of Demanding Projects	36
Process Colling Segment	11	Growing Demand for PTFE Replacements in FR	
Celebration of 25 Years at Vetaphone	12	Applications at NPE2024	37
Global Company Name Rebrand Announced	12	Auto-Profile System for Blown Film	
As World Market Leader Champion 2024		Rotating Dies at NPE2024	38
Awarded	13	Next-Generation Fully Electric eMotion	
Change in the Management Board	14	Welding System at NPE2024	39
Acquisition Completed	14	Melt Filters Made in Italy for the Recycling	
Market Leadership Strengthened	15	of Plastics	40
Change at Management Board	16	Solutions for Manufacturing, Processing,	
Additional Managing Director Appointed	16	Conditioning and Recycling Plastics	42
World Market Leaders	17	Innovation and Services	43
30th Anniversary	18	Extrusion Tooling	
New Management	18	Extrusion Takes Some New Turns	44
Presence in Europe Strengthened	19	Extrusion Technology	
Range of Medical Masterbatches Introduced	19	Concept of Innovation Reinvented by	
Digitalization Meets Recycling – Research Team		Introducing New Analysis Tools	
Develops Tool with Recyclate Data	20	and Doubling the Space Dedicated to Testing	46
2024 Cleanup Champions Announced	20	Film Extrusion	
New Sustainable Packaging	21	Crystal Clear Big-Size Cups – What to be Aware	
PFAS-Free Additives for the Plastics Industry	21	of when Calendering Extra-Thick APET Sheet	47
Strategic Collaboration Agreement Signed	22	Processing	
Chemically Recycled Products with up to 100%		Optimization Process Parameters for PVC	
Sustainable Feedstocks	22	Compounding using a COMPEO Kneader	48
New 800 Series Hybrid Extrusion		Sheet Extrusion – Case Study	
Tooling Announced	23	First Food Grade R-PET Sheet Production	
Mobile Mixing Container		Line to Lithuania	50
on the Market Launched	23	Measurement Technology	
Increased Efficiency in Electronics Production		With Several Innovatins at the wire 2024	52
Through Innovative Quality Assurance	24	Automation	
New Acetaldehyde Control Technology for PET		Quality is our Priority	54
Packaging	24	Blow Molding	
In-House Rheology Lab Launched	25	PET Bottle Life Cycle and NIR Heating	
NPE2024		Technology	56
Will Be the Largest Gathering of Bioplastics		Chinaplas 2024	
Companies In the Americas	26	Indonesia’s Packaging and Automotive	
NPE2024 Features First-Ever Woman in Plastics		Sectors Spur Demand for Plastics	58
Breakfast	27	Measurement Technology	
Impressive Touchdown on the American		Process Automation and Control	
Market – 4 Compact Inline Inspection		of Extrusion Lines	59
Systems on Display at the NPE2024	27	Material Handling	
New Series of OMNI Recycling Machines – Innovative		Gear Pumps Enable Extrusion Industry	
Devolatilization and Decontamination Technologies		to Meet Growing Sustainability Demands	62
for Existing and Emerging Recycling Applications	30		



27

High-performing, user-friendly and easy to integrate into the production line – these are features of the systems PIXARGUS is going to show at the NPE. All inline systems have proven themselves effective on a wide range of standard applications and are ready to start with only minimum set-up effort in any production environment



30

Gneuss' MRS Extrusion Technology is known as an alternative for the reprocessing of contaminated materials. In combination with Gneuss' Rotary Filtration Systems, vacuum technology, an online viscometer and Measurement Technology, customizable recycling lines tailor-made for a specific material can be engineered



50

By mating its energy efficient sheet extrusion lines with Kreyenborg's IR-CLEAN Super-Clean process for post-consumer recycled PET, MEAF Machines can now offer its customers a cost effective alternative for the production of FDA/EFSA approved single layer PET food grade sheet



54

As a market-leading company for adjustable calibration sleeves, CCA cares for the automation of plastic pipe production with long-term experience and know-how. Each calibration sleeve is developed to precisely match the individual production requirements

PET Technologies was among the first companies that adapted NIR heating to the linear PET stretch blow molding machines. The innovative series of blow molders APF-Max is among the first SBM machines of linear type where it was implemented

For over 40 years, iNOEX has been a trusted solution provider of innovative, high-quality measurement technology in the plastics industry. The intelligent, user-friendly systems bring lasting added value to extrusion processes



56



59



Index of Advertisers, companies and fairs referred in this issue

Achberg, Siloanlagen	23	motan	7, 17
Addex	38	Mylar Specialty Films	12
Adsale	58	NPE2024	26
Avient	24	Orion	9
Bausano	43, 46	PET Technologies	56
Borealis	18	PIE	10
BST	24	PLASTICS	20, 26
BUSS	35, 48	Piovan	11
CCA	15, 54	Pixargus	9, 27
Chinaplas	58	PlasMec	13
Davis-Standard	14	PSI-Polymer Systems	62
ELIX	22	Promix	34
Fakuma 2024	8	Rinco Ultrasonics	39
Feddersen	16	Schall, P.E.	8
FIDIC	22	Sikora	13, 52
Fimic	40, Outside Back Cover	Smart-Extrusion	Inside Back Cover
Gabriel-Chemie	19	SKZ	20
GINDUMAC	15	SML	31, 47
Gneuss	30	Stein Maschinenbau	Inside Front Cover+3
Guill Tool & Engineering	Outside Cover, 23, 25, 44	StePacPPC	21
HydroDyn Recycling	18	Tecnomatic	55
iNOEX	41, 59	Tolsa	37
Krall Kunststoff-Recycling	19	Tosaf	21
Koch Technik	11	TROESTER	14
LEHVOSS	36	Vetaphone	12
Leistritz	33	VM Verlag	Inside Back Cover
MAAG	31, 42	Zepplin	16
Meaf	49	Zumbach	17

MEDIA DATA 2024

MAGAZINE · WEBSITE · NEWSLETTER

EXTRUSION

EXPERT MEDIA ON PLASTICS EXTRUSION



02/2024

VM VERLAG
Cologne / Germany

EXTRUSION INTERNATIONAL



The Extrusion International Magazine
is published bimonthly by VM Verlag GmbH.
P.O.Box 501812, D- 50879 Cologne, Germany

EDITOR

Bettina Jopp-Witt (Editor-in-chief)
Tel. +49 221 546 1539
redaktion@vm-verlag.com

ADVERTISING SALES

Martina Lerner
Tel.+49 6226 971515
lerner-media@t-online.de

Bella Eidlin
Tel. +49 152 29907895
b.eidlin@vm-verlag.com

Tanja Bolta
t.bolta@vm-verlag.com
+49 15205626122

ADMINISTRATION

Alla Kravets
Tel. +49 2233 949 8793
a.kravets@vm-verlag.com

PRINTING

maincontor GmbH
Dr.-Gammert-Str. 13a,
63906 Erlenbach, Germany
T.: +49 937294810811
www.maincontor.de,
info@frankhohmann.com

SALES REPRESENTATIVES

China & Asia
octavia@ringier.com.hk,
Tel. +852-9648-2561
maggieliu@ringiertrade.com,
Tel. +86-13602785446

Tokyo PR Inc. (Japan)
Tel. +81 (3) 3273-2731
extrusion@tokyopr.co.jp

Reprints, Translation etc

No part of this publication may be reproduced,
stored in a retrieval system, or transmitted, in any form
or by any means, electronic, mechanical, photographic,
recording or otherwise, without prior permission of
the publisher.

www.smart-extrusion.com



motan

GRAVICOLOR 110

Gravimetric batch dosing & mixing
unit for injection moulding, blow
moulding and extrusion processes.



ZERO LOSS

www.motan.com



The regular work meeting of the Fakuma Advisory Board took place on February 6, 2024. From left to right: Andreas Wittur (P. E. Schall), Bernd Schäfer (Deifel), Bettina Schall (P. E. Schall), Dr. Christoph Schumacher (Arburg), Annemarie Schur (P. E. Schall), Rüdiger Dzuban (Oni-Wärmetrafo), Prof. Dr. Werner Koch (Koch-Technik), Susanne Zinckgraf (Wittmann) (Image: Schall)

Chinaplas 2024

23 - 26 April 2024
Shanghai / PR China
www.ChinaplasOnline.com

NPE2024

06 - 10 May 2024
Orlando, Florida / U.S.A.
<https://npe.org/>

KUTENO

14 - 16 May 2024
Rheda-Wiedenbrück / Germany
www.kuteno.de

Plastpol

21 - 23 May 2024
Kielce / Poland
www.targikielce.pl/en/plastpol

Fachpack

24 - 26 September 2024
Nuremberg / Germany
www.fachpack.de

Solids Dortmund

09 - 10 October 2024
Dortmund / Germany
www.solids-dortmund.de

Fakuma 2024

15 - 19 October 2024
Friedrichshafen / Germany
www.fakuma-messe.de

ICE Europe 2025

11 - 13 March 2025
Munich / Germany
www.ice-x.com

K 2025

08 - 15 October 2025
Düsseldorf / Germany
www.k-online.de

Interplas 2026

02 - 04 June 2026
Birmingham / United Kingdom
www.interplasuk.com

Fakuma 2024

Exhibitors and expert visitors will meet at the 29th Fakuma international trade fair for plastics processing from the 15th through the 19th of October, 2024. It looks like the exhibition halls in Friedrichshafen will be jam-packed once again this year: approximately 1000 exhibitors from 35 countries have already registered – discussions and preparations are running at full bore.

Twelve exhibition halls and several foyer areas were almost entirely booked out in October 2023 with 1636 exhibitors from 40 countries – 10% more than at the previous Fakuma in 2021. "It looks like Fakuma 2024 will also be close to fully booked out again," says Annemarie Schur, Fakuma project manager at trade fair promoters P. E. Schall. "We're extremely busy and our discussions are currently in full swing! High levels of internationalism, satisfied exhibitors, enthusiastic expert visitors, forward-looking topics – we'll surely experience a plastics celebration once again this year," confirms the project manager.

"Fakuma is one of the world's most important trade fairs on our agenda," emphasises Michael Wittmann, president of Wittmann Technology in Vienna. "Fakuma has managed to retain its relaxed atmosphere, even though it's becoming more and more important at the international level. Typical Fakuma visitors are highly qualified, thus making it possible to engage in especially intensive, top-quality discussions."

Wittmann stresses the strong thematic focus on the requirements of the trade fair visitors. Market-ready innovations are showcased at Fakuma, which yield immediate benefits for business operations.

At the beginning of February 2024, the Fakuma Exhibitor Advisory Board pushed the symbolic start button for the industry highlight at a committee meeting.

Fakuma is a genuine working trade fair – pragmatic and highly practical. The tried-and-tested format is highly esteemed by all involved parties. Rüdiger Dzuban, head of marketing at ONI-Wärmetrafo, also emphasises the direct benefits for Fakuma's expert visitors: "For us, as well as for our customers and target groups, Fakuma is one of the most important trade fairs in the German-speaking regions extending as far as Italy and Poland. Emphasis is always focussed on how we can solve potential problems together!" For Werner Koch as well, managing director of Werner Koch Maschinentechnik, there's no question that mutual, pragmatic problem solving is of the essence: "Fakuma is a very important trade fair because we bring people together here and show them how they can do an even better job." Efficiency – in terms of energy, processes and resources – is a very pressing issue this year. "By taking a holistic approach, we're able to identify and leverage enormous potential," continues Koch, emphasising the major benefits. "In addition to maintaining

customer relations, we're also able to establish new contacts at Fakuma and generate orders, from which we benefit as a company. And not least of all, we greatly appreciate Fakuma's unique charm!"

Efficiency will be a key topic at Fakuma 2024 – on several levels and from a variety of perspectives. Increased efficiency in terms of materials and energy consumption is crucial, as are process efficiency and the efficient operation of production systems, because in light of the current shortages of qualified personnel, consistently high levels of quality can only be achieved reliably with easy-to-use control systems and digital assistance. As a result of the new Energy Efficiency Act, German plastics processors will be challenged to a much greater extent to realise their full potential. Fakuma exhibitors will provide tools and solutions for the challenges of efficiency, the conservation of resources and sustainability.

The overall focus of Fakuma is thus on digitalisation, automation, flexibility, energy efficiency and sustainability. The establishment of closed-loop material flows, product optimisation targeted at recycling and the processing of recyclates for high-end applications will also be at the top of the agenda in 2024.

Gold Sustainability Rating by EcoVadis Maintained



Orion announced it has maintained a Gold medal rating from EcoVadis and ranks among the top 2% of the companies assessed by the organization in a wide range of sustainability areas.

Orion improved its score from the previous year, moving up from 77% to 78% by making significant gains in the areas of sustainable procurement and ethics, according to EcoVadis,

one of the world's largest providers of business sustainability ratings.

"The annual progress Orion is making in the EcoVadis assessments is just another example of how committed we are to being a trusted partner for all our stakeholders and becoming an even more sustainable company," Orion CEO Corning Painter said.

Over the past year, Orion has achieved several sustainability milestones.

The most notable achievements include the completion of a series of four projects, with a total cost of more than \$300 million, that involved installing technology that is substantially reducing emissions at Orion's U.S. plants.

The company also continues to be a leader in developing circular products and recently received €6.4 million in funding from the German government and European Union to further develop technology to improve the production of carbon black using circular feedstocks.

Orion S.A.
 orioncarbons.com

Fakuma is advancing a significant development: holistic product conceptualisation and the promotion of recycling and degradability. Design for recycling – this goal is taking shape to an ever-greater extent. Future-proof solutions for packaging, recycling compounds and alternatives to metal are therefore just as much in focus at the trade fair as machines for grinding and crushing, cooling systems and energy-efficient mould temperature control technology, systems for process monitoring and data acquisition, as well as innovations from the field of industrial 3D printing. The increasing use of renewable instead of fossil-based raw materials will be a further topic for discussion as well.

P. E. SCHALL GmbH & Co. KG
 www.fakuma-messe.de

PIXARGUS

IN-SPECT MORE

Surface. Geometry. All-In-One.

Inline Quality Inspection of Extruded Products

NPE2024 | May 6-10, 2024 | **VISIT US: W6792 in**
 The Plastics Show | Orlando, Florida | **West Building Level 2**

www.pixargus.com

10176 International Boulevard, Cincinnati, OH 45246 (USA)

European Plastics Industry

It's been nearly four years since uncertainty took root in the European plastics industry. First, the pandemic and lockdowns, then Russia's invasion of Ukraine and the resulting energy crises. More recently, the rabid inflation and cost-of-living crisis, and the chaos caused by the Houthi militia on the Red Sea – each of these unfortunate events took a toll on all companies along the plastics value chain.

The question is, can the European plastics industry hope for things to gradually start getting back to normal? To find the answer, Plastics Information Europe conducted its 11th market survey, in which over 330 respondents from across Europe took part.

Performance generally trended lower in H2 2023 – more than half the respondents admitted that the results of their commercial activity were worse in H2 2023 compared to H1; a roughly equal share found it either better or unchanged.

The regional split shows that business was primarily depressed in Benelux, where 100% of the respondents said their operations had deteriorated. The picture also seems grim in Central, Eastern, South-eastern, and German-speaking Europe, Italy, and the UK and Ireland. Among the industry sectors, business was particularly challenging for plastics recyclers and only slightly better for the responding companies engaged in polymer and chemical production.

Although another half-year shattered the European plastics industry's hopes for recovery, the general mood is far from its lowest ebb. Over a third of the respondents believe H1 2024 will bring their business much-anticipated improvements, which would be tangibly higher than in H2 2023. Only 16.7% of those surveyed expect new lows.

The closer to home ground, the more confident the respondents feel. On the domestic market, upturn is a likely scenario for 30.4% of those surveyed. When it comes to exports to other European countries, this figure is slightly lower, at 29.2%; only 26.5% of companies believe in the positive dynamics of their exports to non-European countries. Optimism persists in German-speaking Europe and Italy, where half of the respondents look forward to positive developments in the first quarter of the new year.

Since change is the only constant, a shift in investment activity could bode well for the European plastics industry. The share of companies willing to invest seems to be looking up, reaching almost a third, against only 19.7% in H2 2023. This appetite for spending is the strongest since H1 2021.

The dynamics are also encouraging on the other end of the gauge, with only 23.9% of companies admitting plans to downsize investment programmes. While lower than in H2 2023, this is a far cry from the dismal 8% in H1 2021. The share of companies willing to spend more money in H1 2024 is the highest in Spain and Portugal, the UK and Ireland, and Central and Eastern Europe.

Considering the soaring costs along the value chain, it is not surprising that most respondents said their investment plans are primarily focused on cost-cutting solutions, as reported by almost 57% of the participants. Slightly over a quarter of those surveyed expressed readiness to jump into capacity expansion projects – a good result, given that business performance in the past couple of years left a lot to be desired.

The prevalent hiring trend continues – more companies are still letting go of employees than those hiring them. Nearly 30.3% of the respondents admitted to layoffs in H2 2023, against 26.2% in H1 2023. Only 18.2% reported growth in staff, compared with 19.3% in H1 2023. Slightly more than half of the respondents reported no change in employee strength.

There seems to be light at the end of the tunnel: More companies along the plastics value chain plan hiring than the ones eyeing layoffs in H1 2024. Employee retention remains the dominant trend, with 65.6% of the respondents expecting no major changes in workforce. Only 21.3% plan to increase hiring and 13.1% is looking to downsize.

Sales volumes were chosen as the key concern by 63.9% of the respondents, reflecting fears that with not enough demand, businesses might be forced to downsize operations. Selling prices – a factor tightly linked to the general market health – were a concern for 48.8% of the surveyed companies.

Energy costs continue to bother at least 56.1% of the market players, while the cost of materials worries 44.2%; at least 40% of the companies are still marred by labour and salary costs. Though not as high as at the beginning of 2023, inflation is still cause for concern for 44.2% of the respondents. Overall, businesses managed to make ends meet, as the state of liquidity concerns only 10.9% of the surveyed companies.

Artificial intelligence has been around for a while, but it was in 2023 that it went mainstream and started causing chaos on the markets due to the fear of job losses. Apps like ChatGPT sparked discussions about the tectonic shifts such technologies could cause in virtually all segments.

But the European plastics industry is yet to feel the impact of AI and automation. Only 9.8% of the respondents believe their operations are already affected. A slight impact is recognised by 20.2%, while almost half asserted that AI is yet to unravel its potential. Among the areas where managers expect the most help from digital assistants are cost reduction, increased production efficiency, and better management performance.

Stronger Worldwide in the Industrial Process Cooling Segment

PiovanGroup launches a new strategic division in industrial and process cooling, the result of the integration of the business segments operated by the recently acquired Thermal Care and the existing Aquatech. The two companies share a 50-year history of designing, selling, and servicing high-quality heat transfer solutions for the plastics, food, beverage, and 50 other industry segments.

The newly formed division, specialized in innovative sustainable solutions of excellence for industrial process cooling, thus becomes a global player in its market sector, operating worldwide and with a branched manufacturing capability ranging from North America to Latin America, from Europe to Asia, with a widespread service structure capable of ensuring proximity to customers in all countries where its assets operate.

The integration of these business units will provide R&D efficiencies and an expanded portfolio of products, solutions and services capable of serving a wide range of market sectors.

The new division will be headed by Lee Sobocinski, current president of Thermal Care Inc. and will operate under the Thermal Care brand and have global consolidated sales of approximately 100 million euros.

"We are thrilled to create a new strategic division leader in the business of industrial refrigeration solutions. I firmly believe that, under the leadership of Lee Sobocinski and his team, PiovanGroup will become a global benchmark for top-notch heat transfer applications in the polymer, food & beverage, and industrial sectors," says Filippo Zuppichin, CEO at PiovanGroup.

"The creation of the global Thermal Care brand, coupled with the exchange of the institutional knowledge within PiovanGroup into this emerging division, will empower Thermal Care to provide best-in-class assistance to our customers, irrespective of their geographical presence, spanning from preliminary sales engagement to post-sales support. The future of Thermal Care is exceptionally bright, and we are confident that being "better together", we will ascend to new heights, delivering unparalleled solutions in industrial heat-transfer to our valued customers," adds Lee Sobocinski, President at Thermal Care.

PiovanGroup
www.piovan.com



EXPAND YOUR CAPABILITIES

Your competent partner in
plastics processing mixing,
dosing, conveying and drying
Made in Germany

www.koch-technik.com



Celebration of 25 Years at Vetaphone

When Verner Eisby invented corona treatment back in 1951, he could scarcely have imagined that his two sons, Frank and Jan would still be running what has become a leading global supplier all these years later.

And for Jan, 2024 marks his 25th year in the company, although as he remarked: "It's always been a family business, so I've known it from a young age – in fact, there was no way of getting away from it at home!" Beginning in 1999 as Sales Manager of a team of two – the other was older brother Frank who was also running the business, Jan spent much of his early years building sales in Europe.

Over the years, Vetaphone has developed its business in other international markets, especially the USA and Asia, with Jan as Chief Sales Officer (CSO) taking on the task of establishing a sales and support network and training the personnel. Today, the company is represented in more than 100 countries around the world, and since 1999 sales turnover has increased more than tenfold.

"The packaging market has seen dramatic changes over the past 25 years with the growth of filmic substrates and the development of new printing techniques like digital that have replaced the more conventional offset, gravure, and flexo methods in certain sectors. At Vetaphone, we have always invested heavily in R&D and that allows us to reflect these market changes by continually developing our technology – this applies to everything from narrow web corona to sophisticated plasma treatment systems for special applications, and many others in between," he explained.

Commenting on how 'every cloud has a silver lining', he highlighted the effect of the global crash of 2007/8 that forced Vetaphone to rethink the business and restructure its operation to the issues involved with the global Covid pandemic in more recent times and problems with supply chains, raw materials, and changing working practices. "What doesn't kill you makes you stronger, and we're a resilient bunch here at Vetaphone," he quipped.

Looking ahead, Jan sees an exciting and challenging future for packaging with developments in new pro-



Jan Eisby is celebrating 25 years at Vetaphone, the company his father founded in 1951

duction techniques, new substrates, new 'intelligent' packaging products to match changing consumer habits, and a marked improvement in environmental practices around the world. "Plastic now has a bad image in many people's eyes, so it's incumbent on those who work in the industry to change this perspective. That's why Vetaphone has always believed in education because it is the only way that people, whoever they are, can make the right decisions."

In his current role as Chief Business Officer (CBO), Jan is looking forward to developing a stronger educational link within the industry both through the company's agency network and via the Vetaphone Academy.

Vetaphone A/S

www.vetaphone.com

Global Company Name Rebrand Announced

Mylar Specialty Films, a leader in the production of differentiated polyester films, unveiled its global rebranding initiative highlighted by a change in name from DuPont Teijin Films to Mylar Specialty Films. This change applies to all global operations and offices located in the US, Europe and Asia. The choice of the new company name reflects the heritage of the Mylar® brand which was introduced as the world's first biaxially orientated PET film in the 1950's.

"Proudly building on our 70-years of producing Mylar® polyester films, this rebranding is a salute to our history as well as signals our continued commitment to innovation and leadership in the market," said Steve Gendreau, CEO of Mylar Specialty Films. "Mylar Specialty Films is poised to not only meet the evolving

needs of our industry, but to also anticipate them and set industry standards with our commitment to excellence and to our customers worldwide."

The company ownership remains unchanged being a joint venture between Celanese and Teijin, and the company will continue to market the Melinex® PET, Hongji® PET, and Kaladex® PEN range of products in addition to Mylar® PET branded films.

The JV operations with FSPG Hi-Tech Co., Ltd in China will also be re-branded in the near future but will continue to operate as DuPont Hongji Films until further notice.

Mylar Specialty Films

www.mylar.com

As World Market Leader Champion 2024 Awarded

SIKORA is again among the 450 secret world market leaders of the German-speaking economic area in 2024. This is the result of the University of St. Gallen in cooperation with the magazine WirtschaftsWoche and the Academy of German Business Leaders.

Since 2016, SIKORA has been listed for the 6th time in the ranking of the world market leader champions, which is published annually by the WirtschaftsWoche. For this purpose, 450 companies are selected as world market leader by the University of St. Gallen and the Academy of German Business Leaders according to a strict procedure. The winners are number one or two in at least one relevant market segment and have annual sales of at least 50 million euros, at least 50 percent of which is generated abroad on at least three continents. Only official figures are included in the evaluation,

such as published annual financial statements from the Federal Gazette or the latest annual financial statements of listed companies. In the current survey, SIKORA was one of three companies from Bremen, Northern Germany, to receive the award.

Every year, SIKORA invests more than 10 percent of its revenue in the research and development of new measuring and control technology as well as inspection, analysis and sorting systems for quality assurance during the production of wires and cables, tubes, hoses, pipes and sheets, optical fibers or plastics. With around 400 employees in Bremen, Germany, and its 13 operating international subsidiaries, the company offers innovative solutions and customized customer service.

SIKORA AG
www.sikora.net



“ENSŌ” IN MIXING

looking for perfection



in equipment manufacturing for
PVC DRY-BLEND, MASTER BATCH, THERMOPLASTIC RUBBER, POWDER COATINGS, METALLIC BONDING and WPC



PVC 2024 15-18 April 2024
 Edinburgh International Conference Centre
 Stand 18

NPE2024 May 6-10, 2024
 The Plastics Show Orlando, Florida
 West Building Level 2
 Expo Hall - Booth W7189
 Waiting for you!

plasmec
 Excellence in Mixing

PLAS MEC S.R.L.
 Via Europa 79, 21015 Lonate Pozzolo (VA) - Italy
 phone +39 0331 301648 - comm@plasmec.it
www.plasmec.it

Change in the Management Board

TROESTER, the world's leading manufacturer of equipment for the rubber, cable and compounding industry from Hanover/Germany, is starting the new year with a significant change in the company's management. As of January 1, 2024, Thomas Holzer will take over the position of CEO.

Dr. Peter Schmidt, Managing Partner at TROESTER for many years, has handed over the position of CEO to Thomas Holzer. This step is part of the corporate strategy, which aims to maintain continuity in the management of the company and at the same time provide new stimulation for the future development of TROESTER.

Dr. Peter Schmidt will continue to actively support the company in his role as Managing Partner and CFO.

Bernd Pielsticker will continue to manage the operational business as Chief Operating Officer (COO). His proven expertise and skills will therefore continue to make a sig-

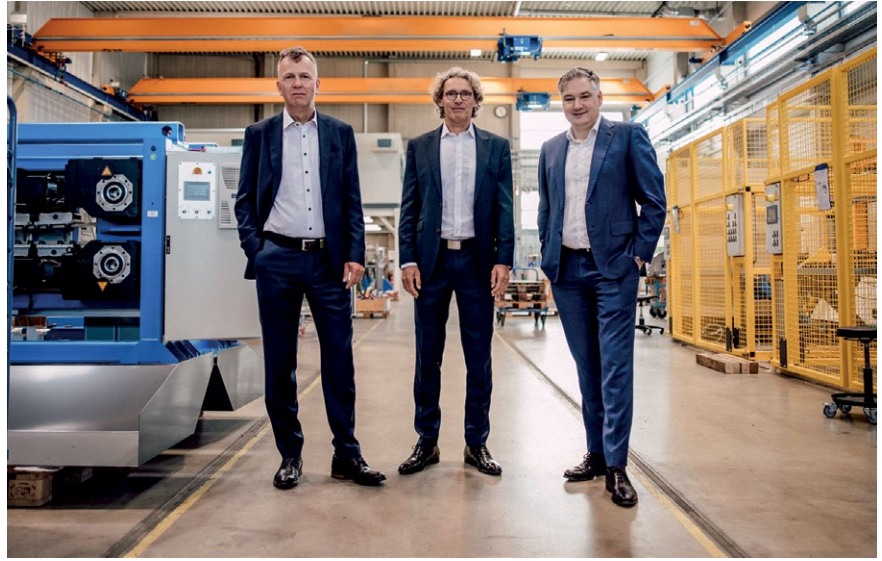

nificant contribution to the stability, efficiency and performance of TROESTER.

"Our common goal in the Management Board is to continue TROESTER's success story and lead the company into new dimensions," says Thomas Holzer.

From left to right: Bernd Pielsticker, Dr. Peter Schmidt, Thomas Holzer

TROESTER GmbH & Co. KG

► www.troester.de

Acquisition Completed

Davis-Standard announced that it has completed the previously announced acquisition of Extrusion Technology Group (ETG).

The acquisition includes three esteemed brands: battenfeld-cincinnati, Exelliq, and Simplas. These additions officially join the Davis-Standard family, marking a significant milestone in the company's strategic expansion. The acquisition further strengthens Davis-Standard's position as an industry leader, combining its expertise with the innovative technologies and market presence of battenfeld-cincinnati, Exelliq, and Simplas. With a shared commitment to excellence, the unified team is poised to deliver unparalleled solutions and support to customers worldwide.

"We are thrilled to officially welcome battenfeld-cincinnati, Exelliq, and Simplas to the Davis-Standard family. This strategic acquisition re-

inforces our dedication to providing cutting-edge solutions and comprehensive support to our customers across various industries," said Giovanni Spitale, CEO of Davis-Standard. "Together, we are well-positioned to drive innovation, enhance operational efficiency, and meet the evolving needs of the global extrusion and converting market."

Former ETG CEO and now President of ETG and member of Davis Standard Executive Leadership Team Gerold Schley stated, "We are delighted to embark on this new chapter as part of the Davis-Standard family of brands. The synergies between ETG and Davis-Standard present exciting opportunities for collaboration, innovation, and growth." Schley added, "We see numerous synergies that will allow us to integrate seamlessly, ensuring a smooth transition for customers of all brands."



Integrating these renowned brands into the Davis-Standard portfolio brings a wealth of knowledge, experience, and advanced technologies. Customers can expect an expanded product offering, increased service capabilities, and a broader geographical presence to serve their unique requirements better.

Davis-Standard remains committed to delivering value to its customers, partners, and stakeholders. The company is enthusiastic about the opportunities that this acquisition creates for collaboration, innovation, and growth.

Davis-Standard, LLC

► www.davis-standard.com

Market Leadership Strengthened

GINDUMAC, Europe's leading transactional platform for used industrial machines, again generated record-breaking results with profitable growth in 2023, powered by ongoing enhancements of technologies and processes.

Order intake doubled in DACH and EMEA supported by more than 900 directly available machines in the categories metal, sheet metal and plastics processing. Over the past years, GINDUMAC has emerged as market leader in Europe, combining platform business and transaction management expertise.

Benedikt Ruf, Co-CEO of GINDUMAC, remarks, "We achieved another outstanding year in 2023, emphasizing process efficiency and customer proximity. We successfully secured substantial market share, maximized customer satisfaction, and enhanced the quality of our offerings."

Despite challenging market conditions in the used machinery market in Germany and continued macro-economic uncertainty on the global markets, GINDUMAC is planning double-digit growth for 2024.

"Our focus for 2024 is expanding our network across Europe," states Daniel Kaiser, Co-CEO of GINDUMAC. "In Asia, we will leverage innovative sales strategies to strategically expand our presence. Our primary objective this year remains to streamline and optimize the used machinery business with platform technology for our customers."

GINDUMAC GmbH
➔ www.gindumac.com

The Co-CEOs of the GINDUMAC Group: Benedikt Ruf and Daniel Kaiser (from left to right)



hoch5.com



CCA
The Original

Quality is our Priority

Backed by 30 years of experience, CCA develops calibration sleeves for plastic pipe extrusion:

- from **Ø 12mm** up to **Ø 2.400 mm** pipe outside diameter
- precisely matched to the production requirements of our international customers

Rely on quality „Made in Germany“.

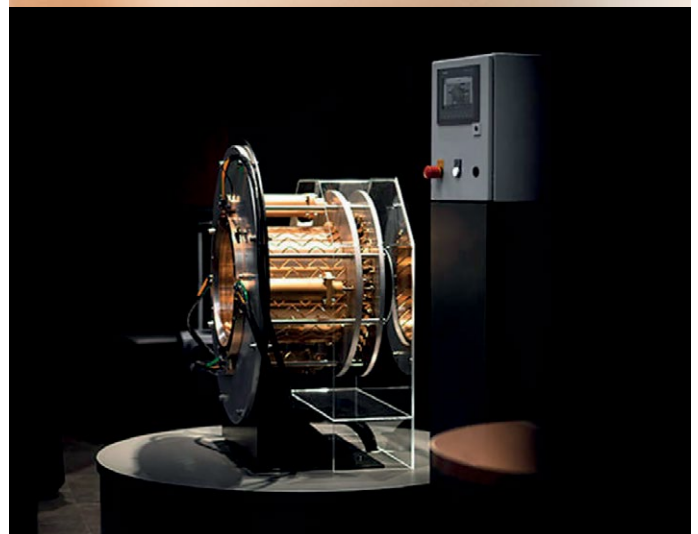

www.ccagmbh.de

Change at Management Board

Matthias Benz will become a member of the Management Board of the Zeppelin Group on July 1, 2024. He will succeed Peter Gerstmann as Chairman of the Management Board on October 1, 2024. This was decided by the Supervisory Board of Zeppelin GmbH at its last meeting in December 2023.

"We are delighted that we have been able to appoint Matthias Benz as Peter Gerstmann's successor," emphasizes Andreas Brand, Chairman of the Supervisory Board of Zeppelin GmbH, Mayor of the City of Friedrichshafen and representative of the shareholder Zeppelin Foundation. "Matthias Benz has many years of national and international management experience and faces entrepreneurial challenges in a strategic, focused and decisive manner – and always manages to take his team with him."

"Peter Gerstmann is passing on an excellent, committed and motivated team to me," says Matthias Benz. "I am very much looking forward to my new role and would like to thank the Supervisory Board for the trust they have placed in me. And I am delighted to be able to take on responsibility for a Zeppelin Foundation company again."

Peter Gerstmann has been Chairman of the Management Board of the Zeppelin Group since 2010 and has worked for the company for 24 years. He informed the Supervisory Board at an early stage that he would not be available for a further appointment and would like to hand over responsibility after 15 years as CEO of the Zeppelin Group.

"I'm leaving at a time of economic and geopolitical upheaval, so for me it's indeed quite difficult to step down," says Peter Gerstmann. "With a view to my suc-



From left: Heribert Hierholzer (Vice Chairman Supervisory Board of Zeppelin GmbH), Peter Gerstmann (Chairman of the Management Board of Zeppelin GmbH), Matthias Benz (as of July 1, 2024 Member of the Group Management Board of Zeppelin GmbH), Andreas Brand (Chairman Supervisory Board of Zeppelin GmbH and Mayor of the City of Friedrichshafen) (© Zeppelin GmbH)

cessor, our management team and the committed employees throughout the Group, our company has proven its resilience in all crises and the course has been set very well." Following his stepping back from the Group Management Board, Peter Gerstmann will be available to advise and support his successor and the Supervisory Board until the end of the year.

Zeppelin GmbH
 zeppelin.com

Additional Managing Director Appointed

On 1 March 2024, Jonas Ehinger was appointed as the new and additional Managing Director of K.D. Feddersen CEE GmbH in Vienna.

Jonas Ehinger already worked for the Feddersen Group from 2013 to 2017 – first in southern Germany as Account Manager of the Hamburg-based plastics distributor K.D. Feddersen and then as Global Key Account Manager of the plastics compounder AKRO-PLASTIC in Niederzissen.

"Jonas Ehinger has acquired in-depth knowledge of engineering plastics, their application, processing and marketing through his mechanical engineering studies

at Aalen University, specialising in plastics technology, as well as through his professional positions, starting in 2006 at an Austrian manufacturer of furniture fittings. During his career, he has successfully expanded his expertise and we are delighted that he has returned to us and joined the management of K.D. Feddersen CEE GmbH," says Dr Stephan Schnell, Managing Director of K.D. Feddersen CEE GmbH.



K.D. Feddersen CEE GmbH
 www.feddersen.group,
www.kdfeddersen.com

Dr Stephan Schnell (left)
 and Jonas Ehinger

World Market Leaders

Every year, the University of St. Gallen, in cooperation with the Academy of German Global Market Leaders, lists 451 German global market leaders. The basis is provided by a database with currently around 1300 entries of potential world market leaders. These companies are filtered and selected according to strict criteria and rules.

Thus, the motan Group was once again recognized as a world market leader.

World market leaders must, among other things, be number one or two worldwide in terms of turnover in a relevant market segment. With an annual turnover of around 147 million euros, the motan Group is in an excellent position. In addition, at least 50% of the global annual turnover of potential world market leaders must be generated abroad and on three continents. With an export quota of >50% on six continents, motan has again more than fulfilled this criterion.

Another criterion is the headquarters of the owners. This must be, at least in part, in Germany. The motan Group also fully meets this criterion with its location in Constance.

The complete list of the 451 world market leaders is published in the current special issue no. 1 of "WirtschaftsWoche" from November 6, 2023 with the title: "The 450 secret world market leaders".

motan holding gmbh
 www.motan-group.com

Zumbach
 SWISS PRIME MEASURING SINCE 1957



RAYEX® S Static X-Ray Measuring System

Benefits:

- ✓ All in one! Complete system for precision measurement of wallthickness, ovality, eccentricity and diameter.
- ✓ Fast measurement, immediate response to product changes.
- ✓ Operator friendly due to smart measurement algorithms.
- ✓ State of the art connectivity with integrated Profinet IO, Ethernet TCP/IP, Ethernet IP, or OPC UA communication protocols.
- ✓ Minimum maintenance requirement.



2

Min. object diameter (mm)



100

Max. object diameter (mm)



up to 20

Scan rate (scans/s)

Zumbach Electronic AG

Hauptstrasse 93 | 2552 Orpund | Schweiz
 Telefon: +41 (0)32 356 04 00 | sales@zumbach.ch
www.zumbach.com

30th Anniversary

In March 2024, Borealis commemorated its thirtieth year of operations. Born of a merger between Statoil and Neste, Borealis has expanded from its early Nordic roots to become one of the world's top ten polyolefins players and driver of industry change. Its dedication to value creation through innovation has produced proprietary and transformative technologies which benefit society and accelerate the transition to a circular economy. The company is regularly ranked as Austria's top innovator in the European Patent Index and holds an extensive patent portfolio of around 8,900 granted patents. In Europe in particular, Borealis has for decades bolstered the industrial landscape by investing heavily in its capital assets, and by providing thousands of highly-skilled jobs in the communities in which it operates.

Borealis Group

www.borealisgroup.com



Thomas Gangl, Borealis CEO: "On the occasion of our 30th birthday, we at Borealis are exceedingly proud of how we have built on our European heritage, along with our technological prowess, to become a global industry player. Industry is the bedrock of societal prosperity. For three decades, Borealis has helped accelerate progress and raise living standards by creating value through innovation. As we drive the industry transformation to a circular economy of plastics, and continue to reinvent the essentials for sustainable living, we will keep investing in our people, assets, and our communities."

New Management

Friedrich Rechberger took over the management of HydroDyn Recycling as CEO on February 8, 2024. Company founder Michael Hofmann focuses as co-CEO on strategic business development and sales. With this strengthening of the management team, the specialists in innovative process engineering for cleaning and processing plastic waste aim to further advance their growth plan and expand their role as a technological pioneer.

For his new role as CEO, Rechberger brings over 30 years of international experience in managing technology companies.

"I am delighted to take on the CEO position at HydroDyn and continue the successful development of

the company," says Friedrich Rechberger. "I am confident that with the dedicated HydroDyn team, we can further advance our mission of a better and sustainable future."

Josef Hochreiter, CEO of the NEXT GENERATION GROUP, and HydroDyn founder Michael Hofmann welcome the addition of Friedrich Rechberger: "With his extensive industry experience and management expertise, he brings the necessary know-how to drive HydroDyn's growth forward and to fully exploit the enormous synergies with the sister companies of the NEXT GENERATION GROUP."

HydroDyn Recycling GmbH

www.hydrodyn.de



Friedrich Rechberger

www.smart-extrusion.com

Presence in Europe Strengthened

As part of its increased commitment in Europe, Krall Kunststoff-Recycling has signed a disposal contract with distributor Sunclear, a leading supplier of semi-finished products such as sheets, multiwall sheets, corrugated sheets, tubes and profiles made of plastic, aluminium and composites in France. As part of this agreement, Krall is responsible for disposing of the recyclable materials generated during cutting or processing as waste at all 16 French branches of Sunclear and their customers. Krall supplies these collection points with its customized pallet cages, which are then filled and transported back to its own company.

The approximately 250 tons of plastic waste generated by Sunclear each year consist mainly of PC and

Krall Kunststoff-Recycling now disposes the rejects collected at Sunclear in France as well as plastic, aluminium and composite offcuts. Grid boxes from Krall are delivered and collected in exchange (© Sunclear)



PMMA, polyolefins (PP and PE), styrenics, PET and PVC, as well as engineering plastics and composites with aluminium. Krall processes the plastics into single-origin re-grind, which can then be used as a direct substitute for virgin material in many applications as part of the recycling loop, saving considerable amounts of CO₂ in the process.

Louis Krall, authorized signatory: "Sunclear attaches great importance to the integration of recycled raw materials and the search for environmentally friendly processes. Our modern technology of pure separation and processing using a high proportion of solar energy fits in perfectly with these objectives. For us, this partnership means a

Authorized signatory Louis Krall after contract conclusion at Sunclear (© Krall)

considerable strengthening of our presence in France. Discussions with their Italian subsidiary and with Sunclear's customers suggest that we will continue to expand our activities in Europe. We are thus underlining our claim to be a top international address for the disposal and reprocessing of recyclable materials that were previously used in architecture, transportation, interior design and advertising, for example."

Krall Kunststoff-Recycling GmbH
<https://kunststoff-recycling.de>

Range of Medical Masterbatches Introduced

Gabriel-Chemie announced the introduction of a cutting-edge product range tailored for the medical industry, specifically designed to meet the stringent requirements of ISO 10993.

This newly unveiled product line features Polyethylene (PE) and Polypropylene (PP) based polymer carrier masterbatches, strategically developed to help streamline bio-compatibility concerns. Gabriel-Chemie's medical masterbatches are poised to significantly reduce product development time due to being a ready-made product range.

Diego Karpeles, Corporate Business Development and Innovation Manager at Gabriel-Chemie Group, expressed enthusiasm about the new masterbatch range: „Our commitment to excellence is reflected in the careful selection of raw materials that align to meet ISO 10993 standards. Moreover, our production process is carried out under ISO 13485 certification, demonstrating our dedication to quality. Additionally, our product range includes specialized laser marking masterbatches.“ Manufactured at the Medical

Masterbatch Competence Centre within Gabriel-Chemie Germany, these medical masterbatches adhere to ISO 13485 certification, ensuring compliance with strict quality standards. The production process involves meticulous procedures, including isolated mixing, extrusion, granulation, filling, and storing. This masterbatch range is not tested on animals in an attempt to minimize animal pain.

GABRIEL-CHEMIE Gesellschaft m. b. H.
www.gabriel-chemie.com

Digitalization Meets Recycling – Research Team Develops Tool with Recyclate Data

Digitalization can massively promote the circular economy. Together with its partners GreenDelta, Cirplus and the Wuppertal Institute, the SKZ Plastics Center has now completed a project that facilitates the use of recyclates. Companies can now use a tool to find and evaluate suitable secondary materials.

Together with its partners GreenDelta, Cirplus and the Wuppertal Institute, the SKZ from Würzburg started the project Circularity Optimization for Plastics (CYCLOPS) in 2021, which has now been completed in 2023. "The ambitious goal of CYCLOPS was to provide buyers and sellers of recycled or waste plastics with a user-friendly tool that allows them to compare materials quickly and easily. The decision to use recycled plastics will be supported by concrete arguments," says Max Meister, Founding Associate at Cirplus.

To achieve this, the last two years of research have involved many small steps – such as evaluating listings and material data, creating software with a strict focus on usability, many tests and countless data comparisons, criteria and definitions. Work that has paid off: The CYCLOPS tool provides information on recyclate applications, achievable prices and their influencing factors, as well as the environmental benefits of recyclates. The overall result is a user-friendly tool that provides a quick overview when comparing sources of recycled and virgin plastic.

Recycling saves up to 90 percent of CO₂ emissions compared to new products - and thus makes a meaningful contribution to climate protection in addition to avoid-



There are still barriers in the recycling market. The CYCLOPS tool, co-developed by SKZ, aims to change this (Photo: SKZ)

ing waste and conserving resources. "CYCLOPS is a milestone in breaking down existing barriers in the recycling market," says Jan Werner, Group Manager Sustainable and Circular Products at SKZ. "The feedback from the first validations at trade fairs has been very promising. We hope to make further valuable contributions in future projects to achieve the transition to a circular economy through coordinated recycling flows."

The CYCLOPS tool is freely available.

SKZ Plastics Center

► Dr. rer. nat. Jan Werner, j.werner@skz.de

2024 Cleanup Champions Announced

The Plastics Industry Association (PLASTICS) has announced its list of 2024 Cleanup Champions. Lead by the Future Leaders in Plastics (FLiP) Community Impact Task Group, the Cleanup Champions Initiative encourages PLASTICS' member companies to use the Guide to Planning a Litter Cleanup to carry out a cleanup in their community in 2024. Each of these companies are dedicated to making a difference in their communities by working to eliminate all material waste from the environment.

"PLASTICS and the entire plastics industry are dedicated to recycling, keeping waste out of our environment, and effecting positive change within our local communities," said Heather Nortz, PLASTICS' Sustainability and Materials Manager. "Our 2024 Cleanup Champions are committed to giving back to their communities and helping our environment. We look forward to seeing all the good work they accomplish this year to make an

impact and help us come together to address the environmental challenges we face."

The 2024 Cleanup Champions are as follows: Advanced Blending Solutions; Braskem; Brueckner; Colour Synthesis Solutions; Covestro; Dart Container; Epsilyte; Industrial Heater Corporation; Pure Cycle Technologies; Schake Industries, Inc; Shawnee Chemical.

The Future Leaders in Plastics (FLiP) Community Impact Task Group was created in April of 2022 to foster collaboration among PLASTICS member companies and external organizations to provide an outlet for the industry to give back and positively impact the environment and communities the plastics industry serves.

The Plastics Industry Association (PLASTICS)

► www.plasticsindustry.org

New Sustainable Packaging

Fresh produce packaging pioneers StePacPPC has customized its award-winning modified atmosphere packaging (MAP) films to preserve fresh whole and sliced white mushrooms, and whole exotic mushrooms. The lean MAP system fulfills consumer demands for sustainable packaging that slows deterioration and dramatically reduces waste of this highly perishable item.

The appetite for mushrooms has been growing rapidly based on their health halo and being a vegan source of meaty umami flavor and texture. Yet mushrooms also have a very short shelf life. Growers and shippers are constantly grappling with these challenges, striving to improve mushroom storage capabilities and curb waste.

StePacPPC's latest advancement in its packaging formats is designed specifically to maintain the freshness of whole and sliced white mushrooms, and whole exotic mushrooms. The customized films significantly slow down decay and reduce weight loss of costly culinary delicacies, preserving texture, nutrition, and flavor thereby effectively diminishing a considerable amount of waste and cost.

The high water-vapor transmission rate of StePacPPC films, coupled with the customized modified atmosphere properties, have proven ideal for preserving the quality of both whole and sliced mushrooms, at once slowing respiration and aging, reducing dehydration, and expelling excess moisture from the packaging.

StePacPPC's packaging first demonstrated its potential for mushroom preservation during the Covid pandemic. Oyster mushroom farmers found themselves with backlogs of produce due to the logistical standstills. StePacPPC's Xtend® bulk packaging solutions were instrumental in helping prolong storage in the cold storage, effectively mitigating waste.

Since then, the company has developed Xtend bulk packaging solutions for lion's mane, shiitake and portabella.

More recently, StePacPPC and its longstanding partner, Windham Packaging, LLC, completed the adaptation of its Xflow™ brand of roll-stock films for automated packing to meet the specific preservation needs of bulk fresh sliced white mushrooms.

StePacPPC's newest Xflow solutions already are gaining momentum in North America, where they are preserving the quality of bulk-packed sliced mushrooms for foodservice outlets such as restaurants and hotels.

These lean and sustainable packaging formats can optionally be produced with 30% recycled material to support a circular economy. This is in conjunction to its longstanding use of mechanically recycled content.

StePacPPC

➔ www.Stepacppc.com

PFAS-Free Additives for the Plastics Industry

Tosaf has developed processing aids for the extrusion of polyolefins that do not contain fluoroelastomers. They can be used without restriction in place of conventional products currently affected by the PFAS debate, are suitable for a wide range of film applications, and they meet the requirements of the FDA and EFSA for use in contact with food. While AP9709PE EU provides enhanced rheological properties, AP9711PE EU is the grade of choice if the focus is on optical properties, including clarity and haze.

In laboratory tests, Tosaf compared the processing properties of a metallocene PE-LLD with those of compounds based on it. One of these contained Tosaf's standard fluoroelastomer-based processing aid (AP-5645PE EU), while the comparison materials contained the alternative PFAS-free products. The results for the flow behaviour in the capillary rheometer and for the pressure reduction in the extruder die were largely consistent. The comparison of the optical properties – light transmission, haze and clarity – even showed slight advantages of the PFAS-free solutions over both the pure PE-LLD and the compound with the previous standard processing aid. The coefficient of friction (COF) showed a negligibly lower value for the film produced with the PFAS-free solution.

Current customer applications include a 5-layer co-extrusion using 1 % of Tosaf's PFAS-free processing aid AP-



Tosaf's new PFAS-free processing aids can be used in a variety of packaging applications in place of conventional products
(© PlasticTime)

9709PE EU in the outer layer. Compared to a standard PFAS-based processing aid, this enables a 5°C to 10°C lower melt temperature and shows a significant lower occurrence of melt fracture as well as improved optical properties such as haze. The films can be printed, sealed and laminated without any problems.

Tosaf Compounds Ltd.

➔ www.tosaf.com

Strategic Collaboration Agreement Signed

International engineering federation FIDIC (the International Federation of Consulting Engineers) has signed a strategic memorandum of understanding agreement with environmental non-profit the Solar Impulse Foundation (SIF) that will see the two organisations collaborating to advance sustainable solutions and drive positive change in the construction technology and consulting engineering sectors.

The Solar Impulse Foundation is a non-profit organisation founded by explorer and clean technology pioneer Bertrand Piccard. Following the success of the first round-the-world flight in a solar aircraft, its mission is to accelerate the adoption of solutions capable of protecting the environment in an economically viable manner. It thus reflects the unifying and realistic approach of its founder around 'qualitative economy'.

Demonstrating that it is possible to address environmental challenges without undermining economic development, the foundation achieved its first goal in April 2021 of identifying and labelling 1,000 'effective solutions', assessed as clean and cost-effective by independent experts. While continuing to grow its portfolio of solutions, Bertrand Piccard and the foundation seek to facilitate the emergence of these technologies on the market by advocating for the modernisation of the legislative framework and by publishing guides to accompany political and economic decision-makers in their ecological transition.

Commenting on the signing of the MoU, FIDIC CEO Dr Nelson Ogunshakin said: "One of FIDIC's core values is sustainability and I am delighted that we will be working closely with Solar Impulse Foundation over the next three years collaborating on a range of projects and ini-



Solar Impulse Foundation founder Bertrand Piccard and FIDIC CEO Dr Nelson Ogunshakin

tiatives that will help to make our industry – and indeed the world – more sustainable."

Founder of the Solar Impulse Foundation, Bertrand Piccard, said: "Engineers play a pivotal role in procuring cleantech for projects, essential for driving the construction industry towards a cleaner, more efficient future. Let's empower them to seamlessly integrate innovative solutions into every design. Leveraging the Solar Impulse Foundation's portfolio of readily implementable solutions, FIDIC and its members gain a powerful ally. Together, we'll launch educational, inspiring and motivating initiatives to empower the change-makers within our industry."

FIDIC, the International Federation of Consulting Engineers

► <https://fidic.org/>

Chemically Recycled Products with up to 100% Sustainable Feedstocks

All of ELIX's Circular Economy activities come under the E-LOOP brand name, with two strategic programmes from ELIX Sustainable Portfolio Solutions: Circular Plastics and Responsible Innovation.

E-LOOP CR products are manufactured with sustainable and certified raw materials that incorporate circular and bio-based feedstocks. These products are certified according to ISCC+ and the mass balance model is used to ensure traceability and transparency throughout the supply chain. Different combinations of feedstocks are possible as there are different sources for the 3 main monomers: fossil fuel-based feedstocks, chemically recycled

post-consumer waste and bio-based feedstocks.

CR products with a content of up to 100% more sustainable feedstocks are now possible, meaning that all 3 monomers (Acrylonitrile, Butadiene, Styrene) can be replaced. Depending on the final mix of monomers, reductions in CO₂ emissions of more than 90% can be achieved compared to prime grades. All products from the ELIX Polymers portfolio can be produced as CR grade, including applications with the strictest requirements, such as food contact, light colours and even medical parts. The material properties remain the same, so there is no need for new material approvals and all of the available technical



(Photo: ELIX Polymers)

data can be used. First OEM approvals have already been received from various industries.

ELIX Polymers was the first ABS producer to receive yellow cards for its E-LOOP products with certified raw materials, as requested by E&E customers and consumer goods segments.

ELIX Polymers

► www.elix-polymers.com
 circular-economy@elix-polymers.com

New 800 Series Hybrid Extrusion Tooling Announced

Guill announced the introduction of a new version of its popular 800 series, known as 800 Series Hybrid. In some extrusion applications that utilize crossheads and inlines, layers of the exact same material are applied multiple times, using a single die. This method is used to reduce the propensity for errors caused by gels breaking through a thin wall, weld lines, inconsistent wall thickness, plus material and process variations. Additional errors include difficult-to-process materials and demanding applications where there is zero fault tolerance.

Seeking to design the next generation multi-layer die to overcome these challenges, the engineers at Guill looked for a way to incorporate this technology into an updated version of the 800 Series. This led to the creation of the 800 Series Hybrid. The inherent benefits of the 800 Series are retained, including compact design, low residence time and a common deflector bore that eliminates tolerance stack up. The challenge was

to create a hybrid design that incorporates the benefits of layer overlapping, while reducing unnecessary complexity and making the technology more cost-affordable for customers. This was achieved by overlapping layers in each semi-deflector, using a single cone. The highly efficient design of the 800 Series Hybrid reduces cost and size, as opposed to other methods of overlapping layers.

Essential benefits of the 800 Series Hybrid include eliminating weld lines in materials through patented overlapping technology, producing a more consistent finished product; reduced sensitivity to changes in viscosity; reduced sensitivity to changes in line speed; myriad material and multi-layer application possibilities; works in all tubing and jacketing applications with a wide range of materials; low residence time; compact design and a low tolerance stack-up error factor, all resulting in improved concentricity.

The 800 Series Hybrid extrusion tool greatly reduces stagnation, be-



cause overlapping layers are more inherently balanced than single layers and also because each semi-deflector is "tuned to flush." Conventional deflectors must simultaneously achieve a balance between flushing, balancing and eliminating the weld line. There is less difference between the slowest moving material and the fastest moving material in the deflector channels, thus making the viscosity more consistent in the deflector.

Guill Tool & Engineering
www.guill.com

Mobile Mixing Container on the Market Launched

The CR.MIX mobile mixing container expands the proven and standardized container product range of Siloanlagen Achberg. The special geometry of the mixing screw allows fast and homogenous mixing of free-flowing plastic granulate or regrind. In addition, the high-quality components on the stainless steel container ensure a long lifetime.

The mixing container can be used wherever small to medium quantities of bulk material need to be mixed. The container is filled as standard via the hinged area of the cover. An inlaid grid is installed there to support bagged goods. To start the mixing process, the hinged cover must be closed and the start button pressed. The mixing process stops by pressing the stop button or automatically after an adjustable mixing time. The rollable container can then be moved to the place of use.

The main added value lies in the special geometry of the mix-



Mobile mixer for plastic bulk materials
 (Photo source: Siloanlagen Achberg)

ing screw, which ensures optimum mixing results without an additional outer tube. This offers the advantage that the interior and the

mixing screw are very easy to clean. "We've invested a lot of development work in the mixing screw and its mixing properties," says Managing Director Gerd Maass.

Because of the steep hopper and the round container geometry, an optimum material flow is ensured. This means that the ready-mixed bulk material can be almost completely extracted at the lowest point of the hopper using up to two special suction pipes. A sensor-monitored swivel slide is attached to the bottom of the outlet for complete emptying. This, as well as the safety interlock of the hinged cover, is monitored by the control unit, which is mounted on the stainless steel cover of the container. The mixing container is supplied with power via a standard 16 A CEE connection, which is also mounted on the round cover.

Siloanlagen Achberg GmbH & Co. KG
www.achberg.com

Increased Efficiency in Electronics Production Through Innovative Quality Assurance

Automation, efficiency and sustainability – these are the areas in which BST offers manufacturers of flexible, organic and printed electronics decisive competitive advantages. The company's portfolio of cross-process and cross-industry system solutions for quality assurance in web-processing industries increases plant efficiency and reduces waste. At Lopec in March, BST presented its ultra-precise "BEST LINE" product line, featuring pioneering innovations for optimum web guiding, surface inspection, web monitoring, register and coating control. The high-precision quality assurance systems FRAMEGuide Pro, regi_star 20 Pro, iPQ-Check Pro and TubeScan Pro with their advanced functions enable a performance that far exceeds the industry standards.

BST's mission is to understand the challenges and problems faced by customers in a wide range of manufacturing industries and to develop systems that help solve them: Through ease of use, long-term process optimization and increased efficiency. "Our goal is to continue to listen to our customers' needs and provide them with holistic solutions to optimize their overall plant operations," says Jörg Westphal, Executive Vice President for the Flexible Materials business unit.

The innovative TUBEScan Pro inspection system offers maximum performance when used in state-of-the-art cutting and assembly machines. The system detects defects even faster and more reliably



The highlight of the FRAMEGuide Pro web guiding system is the high-performance drive: with repeat accuracies of $\pm 10 \mu\text{m}$, it ensures highly accurate control results for every application (Pictures: BST GmbH)

BST presented four key products at LOPEC:

TubeScan Pro – the high-speed inspection system accurately detects print defects with a resolution of up to 0.1 mm, even at speeds of up to 500 m/min. This minimizes waste and significantly improves print quality.

FRAMEGuide Pro – the high-performance web guiding system is ideal for applications that require maximum precision. FRAMEGuide Pro delivers highly accurate control results with repeatability of $\pm 10 \mu\text{m}$ - an invaluable advantage in applications where maximum precision is required. Its compact design and flexibility make it an ideal solution for demanding industries.

regi_star 20 Pro – The high-resolution RSC matrix camera sensor features ultra-precise measurement accuracy and is essential to produce safety and functionally relevant products in printed electronics.

CLS CAM 100 – the camera-based sensor controls the web directly according to objects or motifs in the center of the web to minimize variations in web width and thus improve process reliability and product quality.

BST GmbH

www.bst.elexis.group

New Acetaldehyde Control Technology for PET Packaging

Avient Corporation announced the launch of ColorMatrix™ AAnchor™, an innovative acetaldehyde control technology designed for Polyethylene Terephthalate (PET) packaging. This cutting-edge packaging solution addresses the challenges associated with increased recycled PET (rPET) content by offering improved recyclability and enhancing bottle quality.

ColorMatrix AAnchor technology provides a comprehensive solution to improve the recyclability and quality of PET packaging. As more brands are demanding sustainable packaging solutions, they are looking to incorporate higher levels of recycled material. However, this creates challenges as higher rPET content often requires more acetaldehyde (AA) scavenger, which can lead to issues

related to accumulation, such as migration and increased risk of exceeding regulatory migration limits.

One of the standout features of ColorMatrix AAnchor is a very low tendency for migration, thereby reducing the risk of exceeding regulatory limits, even in closed-loop recycling systems where accumulation and migration risk are highest. Improved thermal stability also offers

improved processability, avoiding processing issues related to sublimation and deposition on equipment and molds, helping to improve efficiency and throughput.

"We are thrilled to introduce ColorMatrix AAnchor to our customers," said Andrea Smith, Global Product Manager at Avient Corporation. "This new technology represents a significant advancement in a shared commitment to sustainability and innovation. By address-



ing the challenges associated with increased rPET content, ColorMatrix AAnchor helps brands achieve their sustainability goals while delivering high-quality PET packaging."

ColorMatrix AAnchor also offers excellent bottle aesthetics and mechanical strength, ultimately potentially extending the shelf life of packaged products while helping control odor and minimize the risk of off-taste in bottle contents. The technology is compliant with European food contact regulations.

Avient Corporation
www.avient.com

In-House Rheology Lab launched

Guill Tool, manufacturers of extrusion tooling for the global market, has opened an in-house rheology laboratory, making it the only extrusion tooling manufacturer in the industry with such a capability. Seeking to obtain better results and minimize the time it takes between testing and production, Guill built its own rheology lab in their facility in West Warwick, Rhode Island, USA. The lab features several key machines that ensure optimum results, when testing materials, especially new compounds to be extruded. The testing equipment includes a Hybrid Rotational Rheometer, a Differential Scanning Calorimeter, and a Thermal Conductivity Meter.

Third-party testing facilities are typically not experienced in extrusion processes. Guill, however, can not only gather data the same way third-party testers can, but can also interpret that data as it applies specifically to extrusion. Likewise, third-parties simply supply data, not recommendations. Guill is now equipped to both test its cus-

tomers' materials and work with them to create extrusion tooling that will give them a competitive edge. Accurate simulation and interpretation by extrusion experts greatly reduces the number of physical reworks needed, as the tooling has a greater chance of producing a good product at the outset. In-house testing also speeds up the turnaround on test results, reducing delays during the tool design process and offering better control over the processes and test parameters.

The new Guill rheology lab processes standard materials, custom formulae and it is equipped to mix materials. These materials include plastics, thermoplastic elastomers, all types of rubber and silicone. Information from the

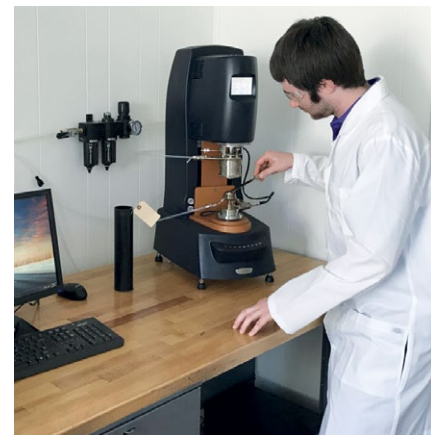

New Guill Rheology Lab at company headquarters in West Warwick, Rhode Island

lab is transmitted directly to the Guill engineering department via computer link for review by the design team.

The lab will be offered for use by extruders and chemical formulators, among others in the industry. Please contact Guill for full details.

Guill Tool & Engineering
www.guill.com

TA Instruments Discovery HR-2 Hybrid Rotational Rheometer



TA Instruments DSC-25 Differential Scanning Calorimeter

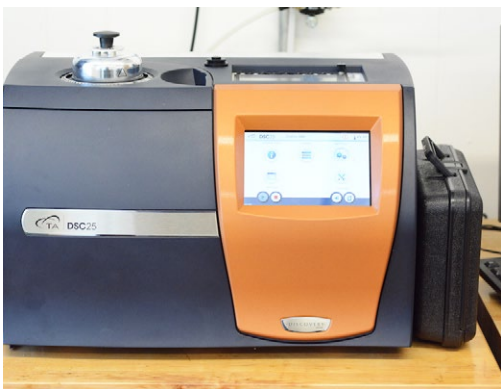

TA Instruments DTC-300 Thermal Conductivity Meter



NPE2024 Will Be The Largest Gathering of Bioplastics Companies In The Americas

NPE: The Plastics Show, Produced by The Plastics Industry Association, Will Feature 1.1 Million Net Square Feet of Exhibits, Making The Show The Biggest Plastics Show In The Americas



NPE2024

The Plastics Show

Produced by  **PLASTICS**
INDUSTRY ASSOCIATION

The Plastics Industry Association (PLASTICS) will foster the continued growth of the bioplastics industry at its upcoming trade show, NPE: The Plastics Show. With more than 45 bioplastics related exhibitors on the show floor, NPE2024 is expected to be the largest gathering of bioplastics companies in the Americas.

Companies such as NatureWorks, LG Chem, Evonik, LyondellBasell and more will display their latest developments in bioplastic polymers and additives across more than 47,000 square feet of exhibits. Attendees will explore the latest materials, technologies and processes offering innovative sustainability solutions, while also hearing from a variety of sustainability experts, suppliers, and manufacturers

Dr. Perc Pineda



on the all-new Sustainability Stage and in two Recycling and Sustainability Zones.

NPE2024 will provide a first-hand look into how sustainable plastics manufacturing is driving value creation for society, the environment and the industry. "We hope registrants will leave inspired to reduce plastic waste as they explore the latest in new end-market solutions, bioplastics, lightweighting, circularity, and more," said Patrick Krieger, PLASTICS' Vice President of Sustainability. "Our first-ever Sustainability Hub will highlight leaders in sustainability and include action-oriented displays in areas such as – renewable feedstocks, collection, sortation, energy efficient manufacturing and more – you will not want to miss it," stated Krieger.

Additionally, made for plastic material suppliers, processors, equipment suppliers, and brands interested in investing in the bioplastics industry, PLASTICS will release its 2024 Bioplastics Market Watch Report on May 8 during NPE. The new edition of the Bioplastics Market Watch will feature the latest market data compared to the 2018 report to show the market growth figures, policy implications and consumer perceptions affecting bioplastics businesses today.

"Through this report, we hope to gain a better understanding on consumer perceptions around bio-

plastic products, their sustainability value and functionality within our industry, including how the bioplastics market outlook has evolved since the last report was issued," stated Dr. Perc Pineda, Ph.D., PLASTICS' Chief Economist.

Over 55,000 individuals are projected to attend NPE2024, the largest plastics trade show in the Americas from May 6-10, 2024 at the Orange County Convention Center in Orlando, Fla. NPE will gather over 2,000 exhibitors to showcase their latest products and innovations designed to drive business forward for every part of the plastics industry, along with over 100 educational sessions and brand-new keynotes from experts in the field.

Patrick Krieger



NPE2024 Features First-Ever Woman in Plastics Breakfast

PLASTICS confirmed the participation of Kerrie Greenfelder, Engineering Director for Burns & McDonnell's Water Division, as their speaker at the first-ever Women in Plastics Breakfast, sponsored at NPE2024 by LyondellBasell and Syensqo. Greenfelder's session is entitled: "Sorry, I'm Not Sorry" (A Tale of Unapologetic Ambition).

"The Women in Plastics Breakfast is an incredible opportunity to hear from strong female leaders. Kerrie's story of empathy and ambition is an inspiration to our community,

and we are honored and excited to unite generations of women in this industry," said Ashley Hood-Morley, Vice President of Industry Engagement at PLASTICS.

The Women in Plastics Breakfast, which will be held on May 7, is one of many networking events at NPE2024 designed to connect industry veterans and young professionals.

"I was honored to be asked to speak at this event and am looking forward to connecting with every individual who attends," stated

Greenfelder. "In any career, transparency and honest communication are vital, as they allow us to learn from one another and grow as an industry – and that is exactly what we will be doing at NPE. I am proud to share my experiences with my colleagues and help pave a way for the future of plastics," concluded Greenfelder.

For more information about NPE2024:

→ npe.org

Impressive Touchdown on the American Market – 4 Compact Inline Inspection Systems on Display at the NPE2024

High-performing, user-friendly and easy to integrate into the production line – these are features of the systems PIXARGUS is going to show at the NPE. The highly compact multi-talent AllRoundDia DualVision checks both the surface and diameter of tubing and hoses with a single sensor. With minimum setup effort, the system is ready for use in virtually no time. iProfilControl is a downsized series designed for complete 360° inspection of profiles of up to 250 mm. ProfilControl 7 S CorrugatedTube checks the surfaces of corrugated tubes, detecting flaws in the tiniest corner. ProfilControl 7 DX WoodPlasticComposites (WPC) provides high-precision dimension measurement and reliable surface

inspection of decking boards made of wood-plastic composites. All these inline systems have proven themselves effective on a wide range of standard applications and are ready to start with only minimum set-up effort in any production environment. The goal is plug-and-play: Simply insert into the line, start, go.

With its turnkey inline surface inspection and dimension measuring

AllRoundDia DualVision: With just one sensor unit, this compact multi-talent for complete 360° inspections of round products checks both the surface and contour of the product. Using "true" LED-based lighting, the system outshines conventional lump inspection systems

systems, Germany-based PIXARGUS is a world leading supplier and innovation driver in automated quality control. Compact in design, the systems are in use 24/7 checking product quality in a wide range of industries,





Quick set-up thanks to plug and play: The AllRoundDia DualVision system comes with product data preconfigured ex works for many materials. The material data can be conveniently selected in the menu of the display

such as automotive, construction & engineering, health care products and consumer goods. Building on a reinforced local sales network, PIXARGUS is ready to further expand on the American market. At the NPE2024 in Orlando, a key event for the global plastics industry, PIXARGUS will be spotlighting its unparalleled range of systems.

AllRoundDia DualVision: The compact multi-talent for complete 360° inspection of rounds

The compact two-in-one system, AllRoundDia DualVision (DV), inspects both the surface and contour of tubes and hoses around their entire circumference with meticulous precision – with just one sensor unit. The PIXARGUS system employs “true” LED lighting instead of laser light as found in conventional systems. A newly developed lighting concept ensures that the field of vision and the measuring field are always perfectly lit. Thus, even difficult to detect irregularities and flaws in the material, such as cracks, inclusions, raised spots, and other high-contrast defects from a size of 0.5 mm, are reliably detected. AllRoundDia DV far outshines con-

ventional lump detection systems. The inline system inspects matte, glossy and even black surfaces of round products with ease, just as well as the surfaces of translucent and semi-transparent tubing.

The system is pre-configured for standard applications. Thus, it is ready for use virtually without any adjustment effort. Its functionality is straightforward and inspection straight to the point. The system comes with a clearly structured, intuitive HMI. It can be operated either directly with the system’s 10-inch touch screen or using a mobile tablet PC.

AllRoundDia DV is currently available for round products of up to 40 mm dia. There will soon be systems for extended diameter ranges of up to 63 mm and 110 mm.

iProfilControl: Smart downsized series for the inspection of small and large profiles – also in multiple-extrusion lines

The downsized iProfilControl (iPC) series comes with proven inspection technology smartly integrated into cost-optimized entry-level systems. In these systems, PIXARGUS has adapted the capacity, range of functions and hardware to the specific inspection requirements of the process to achieve maximum efficiency with minimized equipment.

iProfilControl is based on the proven inspection technology of its big brother, ProfilControl 7. The system comes in three versions: for dimension measurement, surface inspection – and as an all-in-one solution that combines both

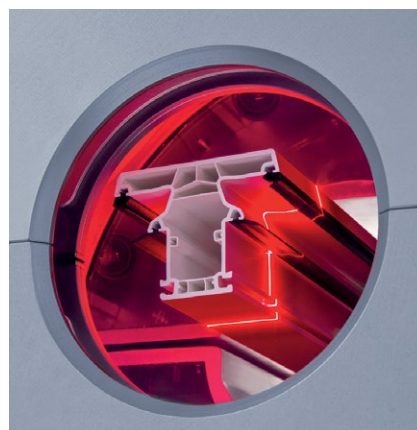

The cost-optimized downsized models of the compact iProfilControl series provide maximum performance at an attractive price – also as a standard solution for the inspection of large profiles of up to 250 mm in diameter

Introductory models equipped with four cameras can be scaled up to six or eight cameras for any future process requirement. Depending on what the customer wishes, the models are designed for 360° dimension measurement or 100 % surface inspection – or, as a combination of both functions, available as an All-in-One solution. Both the software and the sensor unit of the system are based on the successful ProfilControl 7 measuring technology from PIXARGUS. The iPC series comes with an impressive measurement repeatability of 0.01% of the field of vision (FOV) in comparison with competitor systems. The system indicates the smallest irregularities – even before the reject tolerance limit is reached. This allows the production process to be optimally controlled.

iProfilControl is available for FOV diameters of 90, 170 and 250 mm as standard. The 250-mm system is suitable, in particular, for large profiles, and for multiple-extrusion lines. Profiles produced in double-strand extrusion lines can be inspected with the specifically developed software capable of capturing both surface and geometrical de-



ProfilControl 7 S CorrugatedTube masterfully performs the highly demanding task of inline inspection of flexible tubing systems. Easy handling and the capability of performing process-adapted quality control are just two of the system's many strong points

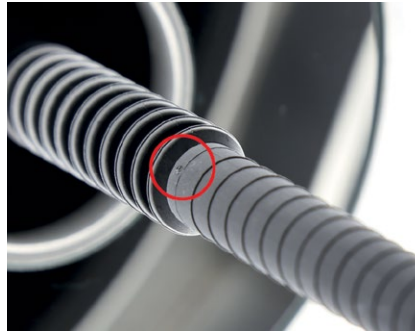

Also extremely small flaws, like the above shown tiny dent in protective tubing for electronic wiring in cars, may easily become safety-critical. ProfilControl 7 S CorrugatedTube assures the quality of corrugated tubing for use in automotive engineering and other demanding applications

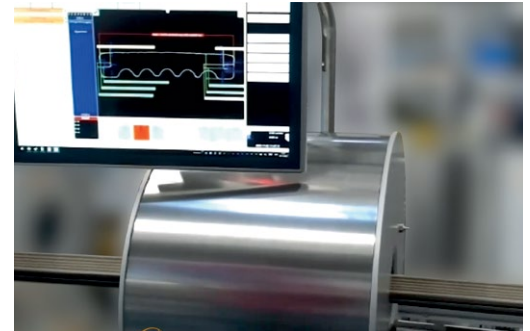

ProfilControl 7 WPC is the system of choice to ensure perfectly shaped decking and cladding boards made of wood-plastic composites. This system checks the entire contours and surfaces of decking boards in a continuous inline process

fects around the entire circumference of the profiles. The compact iPC desk-top devices come with an integrated computing unit. They can be operated via touchscreen, tablet, notebook or PC.

ProfilControl 7 S CorrugatedTube: Reliable surface inspection in quality control of corrugated tubes

What used to be the most difficult terrain for quality inspection is no longer a problem for PIXARGUS: With ProfilControl7 Corrugated Tube it is now possible to inspect the entire surface structure of corrugated tubes – not only the peaks and valleys, but also the transition areas in between – with high precision. The specially developed, in-

novative measuring head features eight high-performance cameras that capture the entire surface structure typical of corrugated tubing from different angles. The inspection algorithms employed automatically recognize and differentiate between plain and corrugated tube sections, thus ensuring that defects such as holes, dents, blisters, lumps, scratches and cracks are reliably detected in all areas of the products. But the software can do even more than that: In addition to their characteristic corrugations, corrugated tubing may consist of periodically recurring sections with features that require special attention. For this purpose, the software includes a dedicated algorithm that, in addition to recognizing where such extraordinary tube sections start and end, automatically adapts the inspection parameters accordingly. This facilitates and accelerates handling at the produc-

tion line, in particular in case of highly diversified product mixes.

ProfilControl 7 CorrugatedTube is designed for the inspection of up to 30-mm-diameter corrugated and spiral tubes.

ProfilControl 7 WoodPlasticComposites (WPC): Dimension measurement and surface inspection of deck boards made of wood-plastic composites

With its highly sophisticated measuring technology, the ProfilControl 7 DX WPC inline system ensures perfect shape of deck boards made of wood-plastic composites. PIXARGUS has masterly adapted its best-selling product family, ProfilControl7, to this challenging inspection task. In addition to measuring the outside profile contour, it excels in checking the quality of critical features. The 8 high-resolution cameras of the system capture radii, angles, distances, lengths, heights and widths inline, during the running process. This fully automatic inspection ensures that, e.g., the deep grooves along the edges for fixing the deck boards are of perfect shape. The system requires minimum handling – from quick commissioning and set-up of the system through to the automated switch-over from one product variant to another.

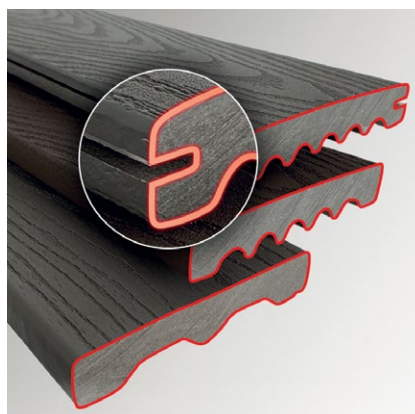

With specially arranged cameras, ProfilControl 7 WPC can reliably and fully automatically check even highly critical features, such as the grooved edges of the boards used to fasten the decking

In the DualVision version, the system simultaneously performs the 360° dimension measurement and the surface inspection of the product. Typical surface defects, such as cracks, notches and edge defects, are reliably detected.

This highly compact system also supports process automation from the extruder through to automated packaging. The intelligent software of the system can also be used to have a fully automatic product grading process based on the previously acquired quality data. Boards graded as defect-free will thus be automatically stacked ready for dispatch.

ProfilControl 7 WPC can inspect up to 250-mm-wide products and is designed to cope with the harshest production environments.

With strong partners on the US market

As part of CiTEX Holding, PIXARGUS collaborates with partners who have specialist expertise in extrusion technology. CiTEX-company iNOEX, for example, are leading experts in x-ray and radar-based measuring systems for round products, with a focus on tube wall measurements. This is a perfect complement to PIXARGUS' successful AllRoundDia-

DualVision technology - a camera-based system for outside surface inspection and dimension measurement of tubes and hoses that performs both measurements with just one sensor head. Through its partnership with iNOEX, PIXARGUS boasts a powerful sales network in the North-American and Asian markets.

PIXARGUS, INC.

10176 International Boulevard
Cincinnati, OH 45246, USA

► www.pixargus.com

**NPE2024: Booth W6792 /
West Building Level 2**

New Series of OMNI Recycling Machines – *Innovative Devolatilization and Decontamination Technologies for Existing and Emerging Recycling Applications*

OMNI Recycling Machines for closed loop recycling

Gneuss' MRS Extrusion Technology is known as an alternative for the reprocessing of contaminated materials like polyester (PET), polystyrene (PS), polypropylene (PP) or polyethylene (PE). In combination with Gneuss' highly efficient Rotary Filtration Systems, optimized vacuum technology, an online viscometer VIS and Gneuss Measurement Technology, customizable recycling lines tailor-made for a specific material can be engineered. As an option, material can be fed into the extruder via a 3C Rotary Feeder.

Several Letters of Non Objection (LNOs) from the FDA, EFSA conformity and local approvals in Latin America confirm the decontamination efficiency of the technology.

Typical applications for OMNI Recycling machines include the

processing of PET reclaim, such as bottle, sheet regrind or fiber waste, into high quality end products, such as thermoformed sheet (suitable for food contact), staple fiber, POY, FDY, BCF or strapping tapes. In addition, a wide range of input materi-



Gneuss OMNI max Recycling Machine with MRS extruder and RSFgenius filtration system



Innovative MRS extruder



Patented Rotary Filtration System RSFgenius

als such as PS, PP, PE, PLA can be recycled. The OMNI series is also used in the decontamination of post-consumer waste for the production of direct food contact products such as HDPE bottle caps, coffee caps and for odor reduction and degassing of PA, SAN or other polymers.

OMNI 130 Recycling Machine for post-consumer PET reclaim on display at NPE

Gneuss will show a complete OMNI Recycling Machine featuring a Multi Rotation System MRS 130 extruder, a water ring pump vacuum system, a fully automatic melt filtration system RSFgenius 150 and an online viscometer VIS. This machine is designed for the processing of up to 1000 kg/h (2,2000 lbs/h) of undried and uncrystallized polyester (PET) reclaim.

The line on display in Orlando will be delivered to a customer in Peru after the show to process R-PET into a thermoforming sheet.

In addition to its compact design, which requires very little space and can therefore usually be easily integrated into existing premises, the OMNI scores highly in terms of flexibility. The fully automated control of vacuum, extruder, dosing, degassing dwell time and filter exchange ensures a consistently high quality of the end product while allowing the operator to use lower cost input materials. With the tight and varying materials market it is becoming increasingly important to be able to produce regardless of the properties of the input materials, especially in the case of varying and uncertain input qualities in the future.

The compact design also results in very low energy consumption. Any energy used in the extrusion process is designed to be used in the next process step. This not only has a noticeable effect on electricity and gas consumption, but also significantly

reduces the CO₂ footprint of the recycling process.

Multiple screw extruder MRS

The MRS extruder is based on conventional single screw technology but is equipped with a multiple screw section for devolatilization. It enables very efficient and gentle decontamination of the polymer melt, whilst achieving the requirements for direct food contact standards. In addition, the MRS extruder permits the processing of R-PET directly into high quality end products such as packaging sheet, strapping tape or filaments without pre-drying by using a simple and rugged vacuum system. All this is achieved by means of its unique and patented processing section. The Multi Rotation Sec-

maag.com

» NEW member of the MAAG Group:

WITE PUMPS & TECHNOLOGY

- PUMP & FILTRATION SYSTEMS »
- PELLETIZING & PULVERIZING SYSTEMS »
- RECYCLING SYSTEMS »
- DIGITALIZATION »

NEXT LEVEL SOLUTIONS

Integrated Systems for Polymer Processing

MAAG Group is the Partner for the Polymer Processing Industry worldwide. All of our integrated solutions from Pump and Filtration Systems to Pelletizing and Pulverizing systems to Recycling Systems have an outstanding performance for demanding customer requirements.

MAAG Group
a **DOVER** company



Gneuss sensors with digital gauge monitoring

tion is a drum containing multiple satellite single screws, driven by a ring gear and pinion transmission.

The satellite screws rotate in the opposite direction to the main screw. This disproportionately increases the surface exchange of the polymer melt. A large opening for venting, exposing the full length of the satellite screws, is completely under vacuum. This provides excellent and unrestricted access to the polymer melt, the surface of which is constantly replaced at an extremely high rate by the action of the satellite screws in the multiple screw section. The surface area – and the surface area exchange rate – available for devolatilization are far greater than in other extrusion systems. As the thermal and mechanical stress on the polymer melt is minimized, reclaim processed on the MRS extruder has excellent optical and mechanical properties.

In a single, simple extrusion step, harmful contaminants can be removed so thoroughly that the resulting recycled pellets are safe for use in food contact applications.

The MRS 130 on display at NPE is designed for the processing of 1000 kg/h (2,200 lbs/h) of R-PET or 750 kg/h (1,700 lbs/h) of polystyrene or polypropylene reclaim.

Vacuum system

Gneuss has developed its own vacuum systems for the extraction of volatile impurities, some of which have patented separation systems. Due to the large melt surface in the MRS extruder, the suction capacity is considerably higher than in conventional systems, so that large

quantities of volatile impurities can be extracted from the polymer and separated from the vacuum flow by means of automated separator systems. In addition to a water ring pump vacuum system, Gneuss also offers deep vacuum systems with appropriate separators.

The vacuum system on display is a water ring pump system designed for vacuums of 25 to 40 mbar and offers high automation and process control with low maintenance, even in recycling applications.

Gneuss Filtration Technology

Gneuss' top model, the RSF *genius*, operates with an integrated back-flushing system offering self-cleaning for very demanding applications and highest quality requirements. Screens can be automatically re-used up to 400 times and filtration finenesses below 10 microns/1200 mesh are available. There will be an RSF *genius* 150 on display, with an active screen area of 450 cm²/70 square inches, for 1000 kg/h (2.200 lbs) of R-PET with a filtration fineness of 75 microns (200 mesh).

Retrofitting a fully-automatic RSF *genius* to an existing extrusion line, whether in a pelletizing, sheet, fiber or pipe application, permits the use of more contaminated (and often cheaper) material and/or the use of finer screens. Every retrofit is tailor-made and usually without the need to move any existing equipment.

There will also be an SF *neos* and a KSF model on display. These filter series also operate continuously and process constant, but do not offer backflushing, therefore these systems are for applications that don't require self-cleaning.

The SF *neos* series operates automatically as well as process and pressure constant. It is suitable for a very wide range of applications including foam sheet, battery separator film or PVC, and is characterized by a large active screen surface area compact design, as well as extremely easy and safe operation. Screen changes do not have any influence on the product quality.

The KSF series is designed specifically for applications with frequent material type, grade or color changes as well as for high pressure applications like blown film. The KSF screen changers are compact and offer excellent value for money while permitting simple and quick screen changes on the fly without disturbing the process.

Online viscometer VIS

OMNI recycling systems as well as any other extrusion line can be equipped with the innovative and compact VIS online viscosity measurement system, which will also be on display at NPE. Using a high-precision, rigid gear pump, a small partial flow of polymer melt is diverted from the main melt channel and forced through a precisely manufactured slotted capillary. The data measured there can be used to improve quality assurance. When processing PET on an OMNI recycling line the viscometer allows precise control of the end product viscosity.

Gneuss Measurement Technology

Gneuss provides flexible sensor solutions for pressure and temperature measurements, individually tailored to your application. Abrasion, corrosion, temperature, Gneuss offers the right solution for every challenge.

Gneuss delivers fast – whether standard sensor or application-specific customized solution. The flexible manufacturing structure allows shortest delivery times.

In addition to standard-compliant pressure monitoring, Gneuss offers the necessary quality assurance of the measuring equipment.

The latest generation of Gneuss sensors and pressure monitors communicates completely digitally. Integrated RFID chips for digital gauge monitoring are available for all sensor models.

Gneuss Kunststofftechnik GmbH

► www.gneuss.com

NPE2024: Booth W5181

Twin Screw Extrusion Equipment for Compounding, Reactive Extrusion, Devolatilization, Foaming and Direct Extrusion on Display at NPE2024

A wide range of twin screw extruders and auxiliary equipment will be exhibited by Leistritz Extrusion on booth #W6343 at the National Plastics Exposition (NPE) to be held May 6-10, 2024 in Orlando, Florida. The theme of the Leistritz Extrusion exhibit will be "The Race to Success", which is representative of the continued advancements made possible via twin screw extrusion to make better products at a lower cost. The following equipment will be displayed:

ZSE-60 MAXX co-rotating twin screw extruder

The most popular production compounding twin screw extruder in North America, the ZSE-60 MAXX features a modular design for barrels and screws that are rated for 425 degree C operation. Auxiliary equipment integrated with the ZSE-60 MAXX includes an LSB-side stuffer for downstream introduction of fillers into the process section and an LSA swing gate strand die with provision for filtration.

ZSE-40 MAXX co-rotating twin screw extruder

Ideal for color concentrates and small lot production, the ZSE-40 MAXX also features a modular design and an LSA swing gate strand die. An AC water-cooled motor is integrated into the machine design, which operates more quietly than air-cooled motors, and eliminates unwanted air flows in the plant.

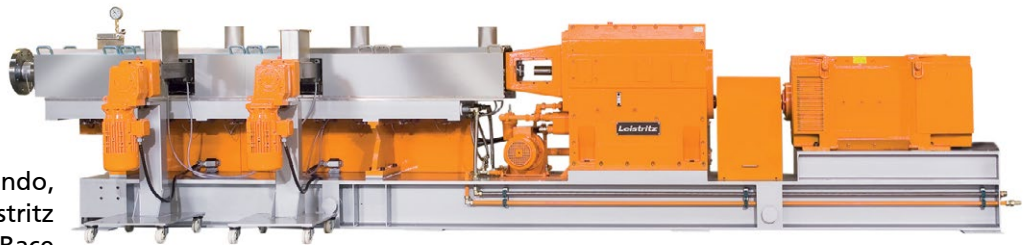

ZSE-27 MAXX co-rotating twin screw extruder

The ZSE-27 MAXX is suited for research and full scale production and features a quick-change flangeless barrels design for accelerated barrel reconfiguration, and the gearbox is attached to a

ZSE-27 MAXX + LSB + AB controls



ZSE-60 MAXX + 52-1 + 2 LSBs

dovetail mounting plate that allows the gearbox to be quickly repositioned to facilitate different length/diameter (L/D) ratios testing. All electricals are integrated into a roll-around stainless-steel base, and an Allen-Bradley PLC/HMI controls architecture will be displayed.

ZSE-12 + micro-plunger



ZSE-18 twin screw extruder

Ideal for R& D, the ZSE-18 offers a fully segmented design and can operate from ½ to 10+ kgs/hr. A base mounted LSB side stuffer allows downstream introduction of fillers, fibers and shear sensitive materials into a process melt stream. A highly customized front-end consisting of a gear pump positive displacement device and candle filtration assembly will be mated to a film die. All electricals are integrated into a roll-around stainless-steel base,

and an Siemens PLC/HMI controls architecture will be introduced at NPE2024.

ZSE-12 twin screw extruder

Exhibited for the 1st time at NPE, the ZSE-12 is suited for continuous operation and is designed for low rate and small batch processing. Modular stainless-steel barrels and screws are assembled on splined shafts. The process section can be configured for liquid injection and multi-stage devolatilization. The feed section is equipped with a pat-

ented micro-plunger feeder, which facilitates processing as little as 50 to 100 gm batches.

Representatives from Leistritz worldwide will be available to meet at NPE2024. Leistritz Extrusion USA is responsible for twin screw extruder installations into North America and parts of South America, and is a subsidiary of Leistritz Extrusionstechnik in Nuremberg, Germany.

Leistritz Extrusion

► www.leistritz-extrusion.com

NPE2024: Booth #W6343

Various Solutions for Mixing, Foaming and Cooling for the Plastics Industry

The focus of Promix's presentation at the NPE2024 is on saving raw material costs, reducing the carbon footprint, increasing production capacity and monitoring production quality.

Microcell Technology saves raw material costs and protects the environment

In plastics processing, materials account for 80% of the CO₂ footprint and this is exactly where Promix Solutions steps in. The Promix Microcell Technology creates a microcellular foam structure in the polymer by adding environmen-

tally friendly atmospheric gases (N₂ and CO₂). This reduces the product weight by 20 to 50 %, leading to significant raw material savings. This not only reduces production costs, but also helps to protect the environment.

The Promix Microcell Technology is suitable for packaging films, sheets, foam core and corrugated pipes, as well as profiles, cable sheathing, blow molding and blown films. Promix will exhibit relevant key components at the NPE and will

provide information on possibilities within specific fields of application. In the meantime, more than 300 industrial references are in operation and various machine manufacturers are successfully integrating the

Promix Microcell Technology on an extrusion line for packaging films

Foamed sheet with Promix Microcell Technology

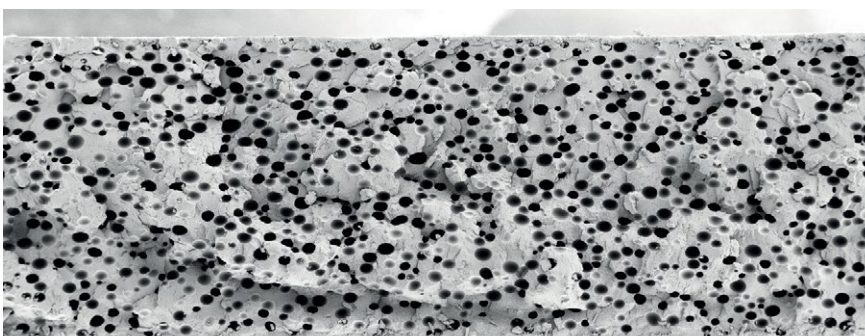

The inline viscometer "Visco P" measures the actual viscosity under processing conditions and in real time (All images: Promix Solutions AG)



technology into their lines. The Microcell Technology can be used for almost all raw materials. The technology is available for new extrusion lines and as a retrofit solution for existing lines.

The smart way to monitor raw material quality and process control

The increased use of recycled material and raw materials from different sources makes it more and more challenging to keep extrusion processes under control. The "Visco-P" inline viscometer from Promix Solutions is helpful in two ways. Firstly, the installed mixer module homogenizes the polymer melt and secondly, it measures the actual viscosity under processing conditions and in real time, directly in the melt stream. There is no bypass and no material loss.

Trend evaluations and reporting tools allow recording of the measurement results with statistical evaluation. User-selectable upper and lower limits for the viscosity trigger an alarm and show the operator current deviations from the target value, allowing corrective measures to ensure a high quality level.

The Visco-P is compatible with all common extruder designs and can be retrofitted to existing lines. It can be used for almost all polymers and is very easy to operate.

Promix Solutions AG
www.promix-solutions.com

**NPE2024: West Hall,
level 2, booth 4649**

COMPEO

Continuous compounding technology for plastics & more

Join us
NPE2024, Orlando, Florida, USA
May, 6-10, 2024
Hall B, Booth W2781

Amazingly flexible. Incredibly efficient. With its COMPEO Kneader series, BUSS offers compounding solutions that set the standard for heat- and shear-sensitive applications, in all industries.

- Extremely short processing time
- Moderate, uniform shear rates
- Significantly lower product temperatures
- Precise temperature control
- Narrow residence time distribution

www.busscorp.com

BUSS
excellence in compounding

“Materializing Ideas” – The Latest Advancements in Plastic Materials for the Fast and Economic Realization of Demanding Projects

LEHVOSS Group, the leading provider of high-performing plastic materials, will participate this year at NPE in Orlando. To stress the significance of the US market and US customers, the LEHVOSS US team will be heavily supported by a strong presence of Material Experts and Top Management from Germany. Attendees at NPE will have the opportunity to explore the comprehensive portfolio of highly advanced polymer materials – Compounds and Masterbatches – designed for a broad range of applications and needs across various industries. Participants will have the opportunity to discuss with the LEHVOSS experts at the booth economically and ecologically optimized solutions for their specific challenges and can learn about the latest trends and demands also from the European and Asian market.

LEHVOSS will present materials of its cutting-edge high-performance compounds and masterbatches, demonstrating the LEHVOSS interpretation of "materializing ideas" and the effective realization of concepts into tangible reality.

The main exhibit for this trade fair is a perfect example how LEHVOSS with its partners materializes ideas: The Buddy X1, is an injection-molded frame for an e-bike made of a LUVOCOM® carbon fiber compound. The material, specially developed for the frame, shows a 60% higher rigidity than competitive materials and it can replace typical epoxy / carbon fiber structures currently widely used in the higher



Photo: Ride through the desert regions of Morocco with e-bikes frames made from LUVOCOM® XCF

end bike market. The frame is fully recyclable and shows a carbon footprint reduction of up to 64% compared to an also recyclable aluminum frame. In February 2024, three E-bikes mastered all challenges in an extraordinary practical test – the Xtreme Tech expedition, a 1,400 kilometers (900 miles) ride in Morocco under the leadership of the well-known adventurer Mike Fuchs, organized by LEHVOSS and supported by many well-known industry partners. Frames and other components made of thermoplastic compounds from LEHVOSS easily withstood all mechanical and weather-related stresses.

A propeller for large agricultural drones is also on display. This is a perfect example how weight reduction and outstanding mechanical properties – maximum strength and

stiffness – have been combined with a good economy and significant improvement of customer value is generated. By consequent application of light weight design in all parts the drones achieve 20 to 40% longer flight times, allowing larger areas to be covered in less time and making life for farmers easier.

Light weight and weight reduction while carefully balancing the mechanical properties is also a key LEHVOSS topic in the area of masterbatches & additives. With newly developed blowing agent masterbatches for injection molding and extrusion the addition of just 1% of masterbatch allows to produce

components for the automotive industry which are 24% lighter while still fulfilling the mechanical requirements. These novel masterbatches are ADC-free and have very good and easy processing properties. Noticeable reduction of sink marks can be already achieved with a dosage of as little as 0.1%. The products are non-toxic and physiologically harmless; thus, they can also be used in other industries such as food.

An example from the semiconductor industry shows very impressively how specifically optimized materials will help to create a significant cost saving and boost productivity. The use of wafer carriers made from novel, electrically conductive and highly durable LUVOCOM PEEK compounds allow a significantly longer service life and the reject rate in production has been reduced by up to 70%.

LEHVOSS will also show innovations in its other focus area of tribologically modified compounds and their typical applications in moving parts such as thrust washers, bushings, ball bearings and gears. In addition to the proven fluoropolymer

modified materials and in response to the current PFAS discussion LEHVOSS will present PFAS free tribological compounds and alternative solution strategies.

In transportation – strongly driven by the e-mobility – but also in the building and construction industry the need for a cost efficient and effective flame protection is strongly growing. LEHVOSS is a leader in Europe for more than five decades when it comes to the flame-retardant modification of plastics. Besides the traditional highly effective halogen-based flame-retardant solutions LEHVOSS offers a full range of halogen-free masterbatches based on nitrogen, phosphorus, and mineral additives with high intumescence for various fields of application. A high level of compatibility to many base polymers is achieved through specially adapted polymer carriers: use cases range from film structures to cables and components with high wall thicknesses. The additive Inovia enables halogen-free flame retardancy of PMMA and PC without any loss of transparency.

"We are excited to bring our theme of 'materializing ideas' to NPE2024," said Dan Salak, President of LEHVOSS North America. "Our customized solutions are crafted to unleash the potential of creative concepts, enabling manufacturers to turn their ideas into reality with exceptional performance and functionality. We are eager to connect with industry professionals and demonstrate the transformative power of our solutions. I encourage anyone interested to contact our team directly at the trade fair with specific problems. In our more than 40 years legacy of permanent technical advancement and shifting the technically possible boundaries further, an extremely deep and broad portfolio has been developed, but we remain determined to find and produce fast economically sensible solutions for our customers. "

LEHVOSS Group

www.lehvoss.de

➔ www.luvocom.de

➔ www.luvobatch.de

NPE2024: South Hall, Booth 23199

Growing Demand for PTFE Replacements in FR Applications at NPE 2024

Tolsa, a leading supplier of flame-retardant synergists and specialized additives for the wire and cable, construction, railway, transportation, and electronics industries, reports growing demand for its ADINS® Additives as a sustainable solution for the replacement of polytetrafluoroethylene (PTFE) as an anti-dripping mechanism for flame retardant formulations. Tolsa will highlight this emerging market trend and identify the latest applications at the upcoming NPE 2024 exhibition.

Since November 2023, Tolsa has seen a 70% increase in demand for alternatives to PTFE as an anti-dripping mechanism, according to Dr. Marta Sacristán, Functional Additives Product Manager for Tolsa. Most of this growth is focused on the production of polycarbonate (PC) and PC/acrylonitrile-butadienestyrene (ABS) compounds and also in polyolefins such as PP and PE. ADINS® Additives meet increasingly stringent regulations as well as environmental, health, and safety standards that are directly influencing



the demand for alternative and safe materials.

"The ADINS® Additives range offers a more complete improve-

ment in fire retardancy properties because they don't just behave as an anti-dripping mechanism but are also a more sustainable solution since much of its content comes from natural sources," said Dr. Sacristán. "ADINS technology is highly versatile and can be fine-tuned to meet the high-performance needs of formulators and end users."

Tolsa has already validated the use of ADINS® Additives as a PTFE replacement in an electric vehicle (EV) battery case application in the U.K. The company is also working with global firms to substitute PTFE in automotive parts and electrical devices, along with other applications.

ADINS® products meet the growing demand for synergists, optimizing not only the consumption of conventional flame retardants, but also providing and enhancing desired properties and functionalities such as anti-dripping, char promotion, significant reduction of smoke

and heat generation, among others. ADINS® technology allows the development of customized grades that guarantee compliance with specific client and industry requirements.

In halogen and halogen-free formulations (HFFR), the use of anti-dripping agents is needed. A commonly used drip suppressant is poly(tetrafluoroethylene (PTFE) which forms a network structure through shearing-induced fibrillation to effectively reduce dripping. However, there is controversy regarding the health risks of this so-called PFAS class of "Forever Chemicals" which includes PTFE. There are health concerns surrounding the perfluoro substances that are used to make PTFE.

ADINS® Additives series products are based on needle-like silicates modified in their surface with organic compounds to ease dispersion in polymeric matrices. This structure reinforces the consistency

of the char, improving its properties and its gas barrier capabilities. This enhanced char decreases heat release and flame propagation, and also reduces smoke emissions and dripping. Key applications include wire and cable, electrical and electronics, construction (pipes, insulating foams, etc.), and transportation.

ADINS® Additives can be used in all types of matrix polymers (thermoplastic, thermosets, and rubber). They work in combination with all kinds of flame-retardant additives (halogenated, hydroxides, intumescents, and P-based). Manufacturers of FR compounds can use the same equipment that is used with other components to manufacture these ADINS®-based formulations.

TOLSA

→ www.tolsa.com/adins

NPE2024: Booth S-30174

Auto-Profile System for Blown Film Rotating Dies at NPE 2024

Addex, a leading supplier of high-performance blown film cooling equipment, will introduce the next generation of its Intensive Cooling™ External Gauge Control (Gen 3 EGC) as a retrofit to existing blown film plastic lines with rotating dies at the upcoming NPE 2024 exhibition. Addex first introduced Intensive Cooling auto-profile air rings at K 2016 for stationary dies only.

The new auto-profile system for rotating dies is based on the company's high-resolution EGC (external gauge control) air ring which can reduce gauge variation by over 50%.

New blown film lines are typically sold with stationary dies, however, there are many blown film producers with rotating dies in operation that need improved gauge control. Conventional wisdom suggests adding an oscillating haul-off to the line, but that isn't always practical due to

budget limitations or physical constraints, such as a tower that is too short, or a tower that can't support



the weight of an oscillating haul-off. Producers have felt the pressure to buy new lines with stationary dies to achieve improved profile performance, since much less expensive retrofit options that allow for a similar performance gauge control on their existing rotating dies simply did not exist. Addex has responded with a new gauge control package based on their new Generation 3 control technology, that retrofits to rotating die lines and controls to the desired 50% reduction level, according to Addex President Bob Cree.

The new Gen 3 EGC for Rotating Die System operates much like Addex's EGC gauge-controlling cousin for stationary dies, but with additional features. The EGC air ring, well known for its very high-resolution control, has a series of "fingers" that open or close to adjust localized air volume. A 300mm/12-inch

air ring, for instance, includes 168 control zones, with 200+ control zones on larger systems. This new rotating die-enabled technology is facilitated by a proprietary mapping algorithm embedded within Addex's latest Gen 3 control technology that corrects for die rotation effects in real time. The new software/hardware system controls not only the auto-profile air ring, but also

simultaneously controls the physical rotation of the die.

"We take over all aspects of rotation and then do auto-profile control in parallel. This allows us to continue to map the measurement of thickness bands to each of the high-resolution control zones, all to within one degree. This has enabled us to achieve some really shockingly good results," says Gautam Jagannathan,

Addex Software Specialist and Senior Field Service Engineer. "We actually surprised ourselves on how well this new system performs, and it's all due to what we do with die rotation and integrated real-time mapping."

Addex Inc.

www.addexinc.com

NPE2024: Booth W5543

Next-Generation Fully Electric eMotion Welding System at NPE 2024

Rinco Ultrasonics, a leading global manufacturer of ultrasonic welding equipment, will announce the world premiere of its next-generation Electrical Motion (eMotion) ultrasonic welding machine at NPE 2024 May 6 to 10 at the Orange County Convention Center in Orlando, Florida. The new servo-driven machine, available in 20 kHz and 35 kHz frequencies, provides superior performance, cost effectiveness, and the latest in user friendly features for the medical device market, according to Serge Patamia, CEO of Rinco Ultrasonics, based in Romanshorn, Switzerland.

"Our next-generation eMotion 2.0 takes electrically-driven ultrasonic welding to a new level, pushing the limits of what our customers can achieve in weld quality and repeatability," said Patamia. "We've developed a more intuitive ultrasonic system that is faster and more efficient to help manufacturers meet today's demanding productivity demands."

An important feature of the next-generation eMotion 2.0 welding system is a completely redesigned microprocessor operating system which significantly increases screen response time. The Linux Ubuntu operating system is logically structured, self-explanatory, and easy to

use, enabling operators and maintenance personnel easy access. In addition, the new operating system doesn't require a licensing agreement like Windows-based systems.

The eMotion 2.0 welding system also boasts a completely new graphical, ergonomic, and intuitive user interface. This user-friendly feature affords operators much greater flexibility, access, and speed. The user interface is easily operated via a larger color touchscreen monitor which provides quick and easy operation. The user interface also provides programmable password protection, offering many levels of digital security and protection.

A new stack mounting feature facilitates easy alignment for quick-change tools. The eMotion 2.0 welder is also fully calibratable and offers permanent audit trails so users can track all system errors and adjustments. To ensure quality and process traceability, all events and changes to the parameters are automatically stored in an audit trail protocol. This permanent audit trail along with eMotion's ISO13485 and Class 6 cleanroom certifications help medical device manufacturers comply with the unique requirements of their industry.

Traceability also helps provide quick diagnosis of any problems. A



Rinco technician, with the help of remote maintenance using an internet connection, can quickly identify any issues and, in many cases, directly correct any parameter errors immediately, reducing valuable downtime.

Unlike compressed air-driven machines, in which the horn returns after every weld cycle to the mechanical home position in the pneumatic cylinder, the starting position with the eMotion can be selected freely to any programmed position. As a result, the weld cycle can often be shortened, depending on the welded object's geometry.

Rinco Ultrasonics

www.rinco-usa.com

**NPE2024:
Booth W2773**

Melt Filters Made in Italy for the Recycling of Plastics

NPE2024 in Orlando is approaching fast after 6 years of waiting, and preparations are in full swing. FIMIC is returning for the third time to NPE with an array of exciting updates, since 2018 FIMIC has developed technologies offering a wide range of automatic melt filters and has integrated into their product portfolio a screw pump called SPA, available in three different sizes to easily transport the plastic melt without using gears that can be positioned before or after the filter. At NPE2024, FIMIC will display its flagship melt filter, RAS 700 model, showing plastics industry insiders and all other visitors how its technology can be adapted to the application requirements and is designed precisely for filtration processes.

FIMIC's booth #W5089 is located in the Recycling Zone on Level 2 of the West Building. "We are fast, we are FIMIC – We make things happen" this year's exhibition tagline, is not just a statement; it is a philosophy with which FIMIC underscores its commitment to providing fast support to customers in a fast-changing industry, by responding to promptly with the solutions they need at every step of the process.

The visitors of the FIMIC booth will be surprised by a 6'7" LEGO model of RAS-UP, the superhero of recycling, a masterpiece that will make both adults and children smile.

FIMIC live on stage for Spanish speakers

On May 8, 9am, FIMIC experts Omar Ruesga and Michele Colom-

bari will present the latest trends in recycling technology along with the most recent innovations to enhance plastic recycling to an international audience during "Seminarios Latinoamericanos". Seminar 2 will be held in Room W315AB, West Hall – Level 3 for those interested in learning in more detail about FIMIC technology with real-life case studies.

Meet the TEAM

NPE2024 is the ultimate networking opportunity and an exclusive occasion to meet the team; FIMIC's CEO Erica Canaia, frontwoman and influential figure in the promotion of Women in Plastics will also participate at the first-ever Women in Plastics Breakfast organized by NPE. The visitors can get in touch with

the Regional Sales Managers who provide timely, local service and support for FIMIC customers in the Americas; Ludovic Pitrois in North America, Omar Ruesga in South America, and meet in person FIMIC's new regional sales manager for Mexico and Central America, Teresa Márquez. Michele Colombari, an expert in the plastics recycling industry and technical support of the entire sales team will also be present to advise recyclers and help them find the most suitable solution to their specific case.

FIMIC SRL

Via Ospitale, 44, 35010

Carmignano di Brenta (PD), Italy

➔ www.fimic.it

**NPE2024: West Building , Level 2,
Hall C Booth W5089**



40
1984-2024
YEARS OF
MEASUREMENT
EXCELLENCE

iXRAY | X-RAY TECHNOLOGY

Precise diameter and wall thickness measurement
of single and multi-layer pipes and hoses



- Measurement of wall thickness, inner and outer diameter, ovality and eccentricity
- Up to 6 wall thickness values on the pipe or hose circumference using advanced 3-axis technology
- 50% more measurement positions than 2-axis systems
- Modern user interface and easy integration
- Full process automation available in combination with iNOEX gravimetry



Get your free
iXRAY White Paper
download now!



iNOEX
INSPIRE BEYOND MEASUREMENT

Solutions for Manufacturing, Processing, Conditioning and Recycling Plastics

At NPE 2024, MAAG will be located in the West Hall, booth W3961. MAAG Group will be presenting its latest innovations in integrated solutions for the plastics industry.

Die Plates – The heart of plastic pellet production

MAAG Group has long been a leader in the development of die plates for underwater pelletizing systems for compounding. Now with the acquisition of AMN, die plates for virgin polyolefin production can be provided. With the combined know-how from industry leaders AMN, Automatik and Gala, MAAG Group offers next level solutions for all underwater pelletizing applications.

MAAG will also exhibit the new PEARLO X Series pelletizer for throughputs of up to 40 t/hr. Its high level of automation allows start-up and shut-down at the push of a button, while wear-optimized cutting tools maximize production times while minimizing downtimes and waste.

Filtration solutions from extrusion to virgin polymer to mechanical and chemical recycling

MAAG, a long-time leader in melt filtration solutions, will display a variety of solutions for all plastics filtration. For extrusion applications, the FSC, flat screen changer, offers ultra compact design and optimized residence time.

With the DFS-BF, our Duplex large area filtration systems are now backflush capable. This capability is due to the Divexpro valve. In addition, Maag will display new innovations in candle filter and vessel connections that eliminate pain-points in these products.

Another new product that MAAG will be presenting at NPE 2024 is the ContiNeo. The back-flush screen changer combines the advantages of a single-bolt screen changer with those of a continuous dual-piston screen changer with backflush functionality. Ideal for extrusion processes requiring low pressure fluctuations and fully automatic operation in a small space.

At the heart of the mechanical recycling portfolio is the high-performance melt filter from Ettliger. The continuous-running machines are specially designed for highly contaminated post-consumer recycling applications.

The REX Duo plus with Vectored Air Technology enables a throughput increase of up to 25% while improving powder quality

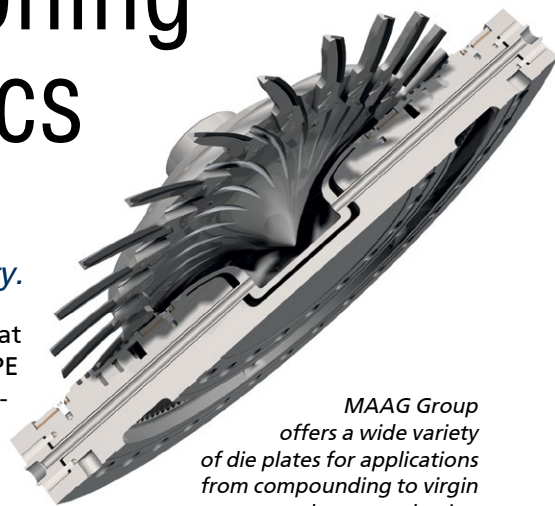

MAAG Group offers a wide variety of die plates for applications from compounding to virgin polymer production

The ERF and ECO series can deliver throughputs of up to 10 t/h depending on the application. On display at NPE 2024, will be an ERF 1000, the largest Ettliger continuous filter available.

Flexible pelletizing for compounding and master batch applications

The tried and proven PRIMOPlus 300 dry-cut pelletizer with double-sided bearings of the cutting rotor ensures high stability and precision, resulting in excellent quality of the cylinder pellets. A JSG pelletizing system model will also be on show at NPE 2024. The fully automatic system is suitable for compounding applications up to 9 t/h. Flexible cooling lengths allow processing of a wide range of materials, and broken strands are automatically rethreaded into the pelletizer.

Increase Pulverizer throughput with Vectored Air Technology

Developed with CFD analysis, the new Vectored Air Technology mill housing enables throughput increase of up to 25% on the REX Duo Plus pulverizer. This new pulverizer technology also improves powder quality and flow for rotomolding applications.

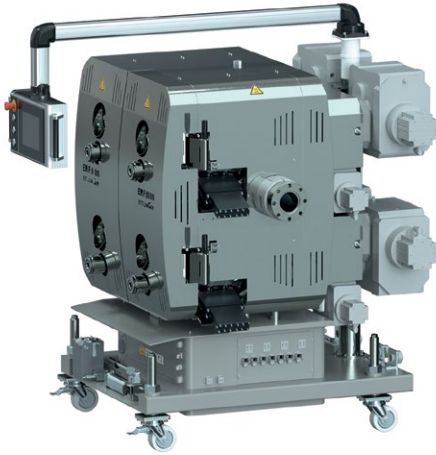

High-performance melt filters remove impurities and contaminants from the recycling melt stream

Service and after-sales based on personal commitment and know-how

Service from MAAG means: Support around the clock, worldwide, in person or remotely. In addition to MAAG Group service and support,

customers can find information and sign up to the recently launched "myMAAG" e-shop, which offers custom and plant-specific spares and wearing parts at the click of a mouse any time 24/7.

MAAG Group
www.MAAG.com

NPE2024:
West Hall, booth W3961

Innovation and Services

Bausano on the occasion of NPE2024 will give the preview announcement of the opening of its new headquarters in Charlotte, North Carolina. The event represents a strategic opportunity for the company to share, with Industry Operators, the consolidated expertise of its Team and its Total Solution, consisting of advanced extrusion technologies and services. Specifically, innovation takes center stage, at booth W929D in the West Hall Building, where the spotlight will also be on Bausano's next-generation MD 92 Nextmover twin-screw, equipped with the Multidrive system and Digital Extruder Control 4.0.

"This investment is part of a broader strategic framework along two main lines: customer intimacy and technological excellence," says Clemente Bausano, Bausano Vice President, who continues, "The state of North Carolina is an important commercial and industrial crossroads for the plastics extrusion sector along with the Gulf of Texas and Louisiana. In this sense, the opening of this new site stems from the desire to be even closer to our Customers, combining customized solutions, under the banner of technological excellence, with a first-rate onsite after-sales service, guaranteeing efficient production processes."

The company invests in advanced technologies not only to constantly monitor extruder operating conditions, but also to optimize available resources and reduce energy consumption, in response to the

Manufacturing Industry's need for superior long-term sustainability. An approach that is developed around three cornerstones aimed at optimizing the extrusion process: from Digital Extruder Control 4.0, for precise monitoring of the energy consumption of each individual production phase, to Smart Energy, the first on the market to heat the barrel by induction coils, to Multidrive, a patented transmission system that allows the distribution of the coupling force over four shaft-motors, controlled by a single static frequency converter, for constant rotation and perfect synchronism of the motors.

Bausano's Digital Extruder Control 4.0 is the reliable screening tool for extruder and end-of-line energy performance. It is an intuitive interface, allowing screw speed to be adjusted, temperature to be controlled, and alarm thresholds to be set, even remotely, with a view to vertical integration of control technologies. In addition, the ability to customize multiple configurations and to consult, at any time, the archive of statistics, facilitates predictive and preventive maintenance activities, with positive results in terms of Overall Equipment Effectiveness.

The exhibition showcases the Smart Energy temperature control system, developed by Bausano to keep the temperature of the processed material constant and reduce heat loss. The innovative technology applies the principles of electromagnetic induction to the extrusion process for faster and more uniform

heating, guaranteeing consistent extrudate quality and efficiency, as high as 95% for net energy savings of 35%.

Finally, the in-house R&D Team, with a view to supporting customers in achieving their productivity and quality goals, synergistically integrates mechanical and ICT technologies in favor of intelligent remote control of each extrusion plant and intuitive operator-machine interaction. Condition Monitoring, according to Bausano, paves the way for a proactive approach to maintenance, which brings with it numerous benefits for Customers such as enhanced operational efficiency due to the full availability of the extruder over time, the extension of its service life, as well as optimal working conditions.

"We are excited to welcome visitors to NPE to delve together into the news inherent in our Total Solution, consisting of advanced technologies and services," says Giorgio Critelli - General Manager at the helm of Bausano USA who concludes "The bonus of having an extremely well-stocked warehouse, with original spare parts and a team of technicians who intervene within 48h of the call, positions Bausano as a strategic and reliable partner able to support companies on a daily basis in overcoming the challenges of an extremely competitive and constantly evolving market".

Bausano
www.bausano.com

NPE2024: Booth W929D in the West Hall Building

Extrusion Takes Some New Turns

A longtime global leader in extrusion tooling for medical tubing and other products, Guill Tool has achieved a series of successes in the areas of multi-layer dies and, most recently, a reciprocal tubing die for wound draining that reconfigures the internal chambers of the tubing to accommodate drainage.

Drain tubes can be inserted prophylactically to prevent or remove the accumulation of fluid in a wound. Alternatively, such tubing can also be therapeutically inserted to evacuate an existing collection of fluid in a wound. Fluid is removed in order to treat or prevent infection and promote wound healing and patient comfort. Drain tubes can also be used to diagnose post-operative complications such as an anastomotic leak or hemorrhage. The Guill design has unique features that eliminate the need to weld or otherwise join sections with different profiles together.

"Our automated extrusion process drastically changes the extruded profile in production, with no need to join separate sections of internal profiles," comments Tom Baldock, Sales Manager, Guill Tool

Guill has engineered this new reciprocal tubing die with various features, unique to the product. The traditional tip and die assembly is replaced with a linear reciprocating assembly that changes the tube's profile within a given length. This process is repeated throughout a single extrusion run without interruption. Cutting capability, in association with the extrusion speed, cuts the finished product to length.

While cost and value stream activities are reduced, quality is actually improved. Only one extrusion run is needed to produce a finished product, as opposed to multiple extrusion runs with tooling changes along with a manual assembly operation to connect different tubing shapes via sonic welds or other methods of joining. Guill's new reciprocating head eliminates this entire assembly operation. It also eliminates in-process inven-



Internal configurations of different designs used on wound drain and surgical tubing no longer require separate sections to be extruded, then joined. The Guill reciprocating head design produces various profiles within the tubing in a constant production run

tory. Thus, there is no need for storage of various tubing shapes and connectors needed for assembly, fulfillment of orders and replenishment of finished goods.

Furthermore, the reciprocating head eliminates a connecting piece, allows JIT production and products made-to-order. Lastly, it reduces total run time from receiving the order to shipping product.

In the multi-layer extrusion arena, a primary focus of Guill Tool over the years, the company has also introduced the latest generation of its Series 800, the 2-to-6 layer extrusion tooling designed to produce the highest quality, highest material-efficient 1/8" to 6" OD tubing for medical and surgical applications. The redesigned Series 800 produces flawlessly smooth extrusion and layer definition of Fluoropolymer and other materials for all multi-layer, multi-lumen medical tubing. The Guill design further allows thin layer combinations of polymers and adhesives to 0.02mm or less.

Guill offers its extensive line of crossheads and inline tubing dies in fixed and adjustable center, for single or co-extrusion applications. The tooling is designed to process all compounds and features the company's patented, precision Feather Touch Concentricity adjustment, the Seal Right System, which combines with the Feather Touch system to eliminate polymer leaking. Guill also offers its unique spiral flow distribution system.

All Guill tooling is produced with rigorous computer simulation of the flow channels using Computational Fluid Dynamics (CFD) programs, resulting in optimum uniform flow with no weld lines.

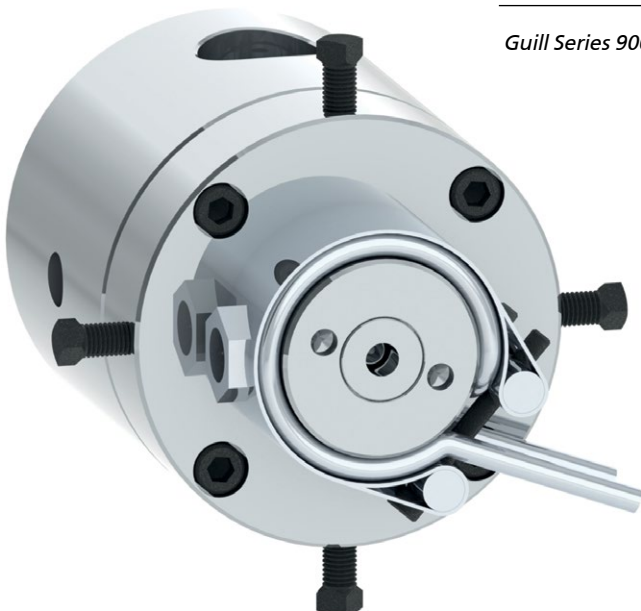

Guill Series 900

Finally, the new Series 900 of inline tubing dies from Guill Tool offers improved extrusion performance and capabilities to customize at standard, off-the-shelf prices.

The new series is applicable to extrusion of hose or pipe ranging from 0.005" (0.127mm) to 8.0" (635mm) in diameter for all types of OEM, food service, automotive, industrial, telecom and medical applications in polymer or rubber.

The Series 900 technology offers these key benefits:

- Achieves concentricity or "product roundness" which greatly reduces material usage compared with other types of extrusion tooling
- Spiderless inline-designed heads results in no spider lines and allows room for more air – thus eliminating cold legs, which can inhibit product output
- Runs 1 to 5 layers simultaneously
- Engineered for a multitude of applications – including special fluoropolymer applications

A key Guill Tool technical highlight of the Series 900 is a patent-pending FeatherTouch™ adjustment in the die holder and a cartridge-style ball assembly that does not require the loosening of retaining screws to make adjustments. Additional unique benefits of the Series 900 include Guill's Seal Right Systems, a positive seal, which eliminates leakage between deflectors, along with easy self-alignment that reduces operator error during assembly and is adaptable to a variety of specific extruder layout configurations.

"This series offers a standard platform design of the head with specific characteristics that are unique to individual applications included at no additional charge in the cost of the tooling. This is a tremendous benefit to a company that requires precision tooling with custom benefits at a standard off-the-shelf price. That certainly helps our customers' bottom line," says Tom Baldock, Guill Sales Manager.

Guill Tool also manufactures tips, dies, and breaker plates using state-of-the-art computerized CNC machin-

Guill Series 800

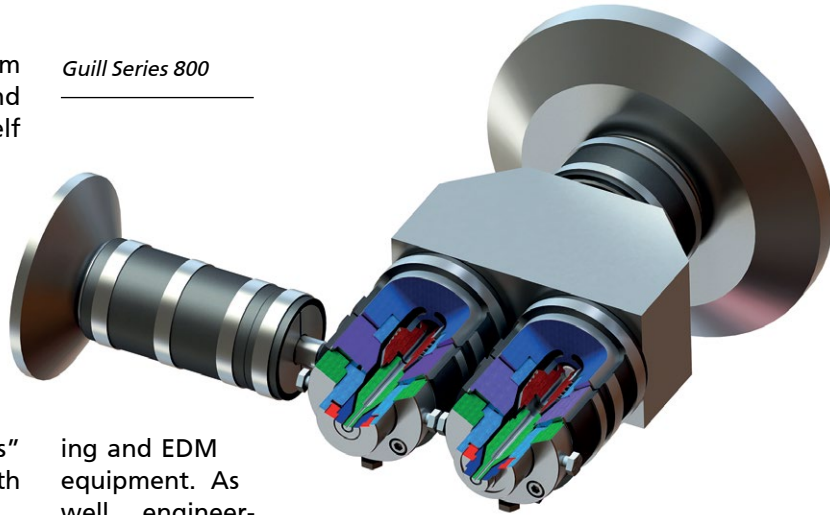

ing and EDM equipment. As well, engineering services using the latest CAD systems are available for custom-designing extrusion tooling product such as crossheads, tips, clamps, flanges, forming rolls, spiderless inline dies, dies, swing gates, breaker plates, special equipment and sizing dies.

Guill Tool received ISO certification in 1995. The first major extrusion tooling company to meet international standards, Guill Tool has long been recognized as one of the leading established designers and manufacturers of custom extrusion tooling for applications including wire, cable, fiber optics, medical tubing, wood composites, automotive tube, plastic compounding, custom applications, rubber, profile, industrial pipe, hose/tube, blow molding, plus food and packaging.

Guill Tool also encourages and provides education and training for the extrusion industry with plastic and aluminum model heads, fully illustrated operating manuals for step-by-step assembly and disassembly, training videos, and classes on the care and cleaning of extrusion tooling.

Founded in Rhode Island in 1962 by A. Roger Guillemette, Guill Tool was established as a job shop supplying tips, dies, crossheads and replacement parts to the wire, cable or wire and cable, plastic and rubber industries in New England. Later, Guill Tool became a supplier for the entire United States and Canada, and today enjoys a worldwide market presence.

Technology in the Medical field is constantly evolving, and often requires an extensive array of Medical grade tubing in a variety of materials and thicknesses. Guill specializes in working with clients to design and manufacture Custom Extrusion Tooling to produce an unparalleled range of the highest quality Medical tubing in the industry. The company's Micro Medical tooling can extrude tube thinner than a human hair, 0.008" or finer per revolution, and can be used to keep procedures as non-invasive as possible. Other models are used to produce tubing for feeding applications, including nasogastric and jejunal tubes.

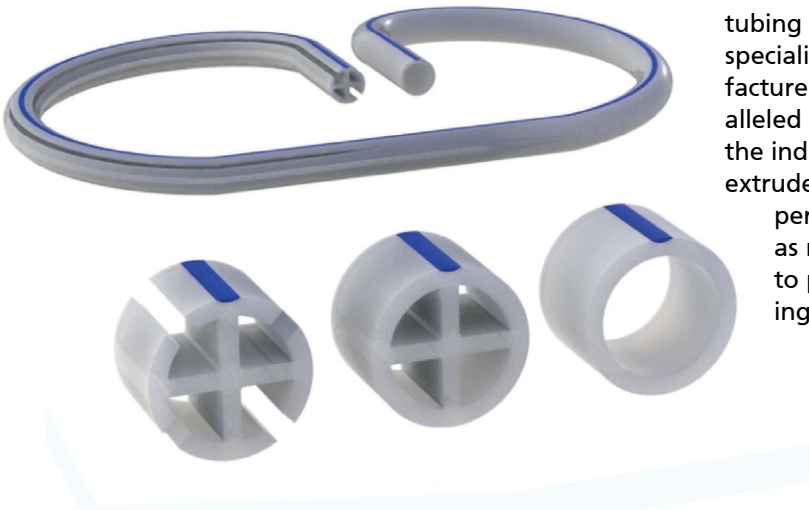

Concept of Innovation Reinvented by Introducing New Analysis Tools and Doubling the Space Dedicated to Testing

Bausano is not only driving technological progress in the production of extrusion lines, but is also strengthening its R&D department and reinventing the concept of innovation with the introduction of new analysis tools and doubling the space dedicated to testing. To this end, Bausano provides a wide range of services through which customers can experience the company's quality in the design of their systems.

Thanks to the dedicated test and experimentation laboratory, in fact, Bausano offers an exclusive working method, which starts from the customer's specific formulation to elaborate structured analyses, aimed at making each extrusion line completely tailor-made. Indeed, before designing a system, analyses are carried out at Bausano using the capillary rheometer, which studies the behaviour of the material when it flows and deforms, in order to understand its viscosity as a function of the shear rate gradient. With rheological material characterisation, Bausano is able to:

- 1) define the type of materials that can be extruded on an existing plant;
- 2) optimise head design;
- 3) fine-tuning the design of the screws.

At the same time, the information collected is processed using a plastograph. Here, the customer's starting materials are fed into the chamber, where they are heated and undergo shear stresses between two counter-rotating rotors. During machining, the torque applied to the rotating screws is measured, which provides information on the viscosity of the molten material and thus on any changes produced by machining on the system (gelation, branching, degradation).

The result of these analyses, a fundamental and distinctive preliminary step in Bausano's know-how, is compared with data processed by software dedicated to fluid-dynamic analysis. This pre-design phase allows the development of new extrusion heads, dies and screws to be optimised by predicting exactly how the material will behave during the machining process.

Bausano's work process also differs in that the data returned by the laboratory instrumentation can be tested in advance at its factory. As a matter of fact, the company is expanding its premises and doubling the space dedicated to the test room for its customers. Specifically, Bausano has two counter-rotating twin-screw extruders MD30 and MD75. The first, for small produc-



tion trials, allows the customer's formulation to be introduced into the machine and the extruded output to be observed before the line is scaled up to industrial level. The second, dedicated to trials on medium-sized plants, is aimed at guaranteeing the productivity targets required by the customer and providing the latter with a sample of material so that it can also be subjected to internal quality controls. Further enhancing the test are two more complete systems, available to Bausano customers. The first, based on an E-GO single-screw extruder for testing PP/PE base blends for the production of single and multilayer pipes, and the second, based on a single-screw extruder from the E-GO R range to test the possibility of regenerating waste materials.

The uniqueness of Bausano's services therefore lies in being able to test the customer's system twice, firstly at its own site. Prior to setup at the customer's production site, Bausano starts up the line in its own factory, either in the presence of the customer or virtually, to validate the design assumptions and test its performance, operation and noise levels. Bausano technicians are thus able to intervene promptly even before the factory acceptance test (FAT), guaranteeing maximum flexibility for

the customer. In this way, Bausano offers a space where customers can refine their R&D, for a concept of innovation that goes beyond technological progress and also embraces the value-added services sector.

"The priority for Bausano is customer satisfaction. This is why our distinctive feature lies both in the exclusive range of pre-design services which, starting from the customer's formulation, allows us to tailor-make the best extrusion line, and in the possibility of verifying the design itself with double testing." says Giovanni Bausano, R&D Manager, who concludes, "In addition to this, there are the after-sales services, which include an extremely well-stocked warehouse of accessories and original spare parts, and a specialised, timely assistance, both onsite and remote, for an all-round support capable of reducing machine downtime and guaranteeing continuity in the production department. A combination that positions us as a reliable partner along the entire value chain."

Bausano & Figli Spa
C.so Indipendenza 111, 10086 Rivarolo Canavese (TO), Italy
www.bausano.com



Crystal Clear Big-Size Cups – *What to be Aware of when Calendering Extra-Thick APET Sheet*

Calendering is a common method to produce extra-thick APET sheet for the thermoforming of big cups containing up to one liter in Europe or 32 ounces in the US. To obtain a crystal-clear product, a couple of fundamental factors must be taken into consideration. The intrinsic viscosity (IV) of the melt is a key to any successful production.

"If a glass-like quality is required for thermoforming APET sheet in the range from 1,200 to 2,000 microns, manufacturing becomes relatively demanding. Process knowledge is a basic prerequisite for a successful production," Rupert Becker, Product Manager at SML, comments.

Choosing the right raw materials: IV value over 0.78 g/dl

A highly viscous melt is essential for the production of crystal-clear, extra-thick APET sheet. Using raw materials with an IV value higher than 0.78 g/dl, in combination with pre-drying and single screw extrusion, guarantees minimum IV loss for the melt throughout the production process as a whole.

Calendering on slanted roll stacks

A slanted roll stack allows the highly viscous melt to stabilise before entering the nip, where the sheet thickness is determined. Disturbances or interruptions with



regard to the melt bead can be largely excluded. This contributes enormously towards the formation of highly transparent APET sheet, the optical quality of which is comparable with PC or PMMA sheet, that are usually also manufactured on slanted roll stacks.

Paying attention to detail

High quality components are important. To prevent scratches, dots or dents on the sheet surface and attain the demanded quality at high output, the surface of each roller – from the roll stack to the winder – has to be with premium surface finish.

The web guiding at all rollers, and especially the wrapping angles and the diameter of the guiding rollers, must be aligned for processing extra-thick sheet.

Last but not least, the optimum fine settings all over the process and the right tension settings on the sheet web are essential for successful production.



Keep dust away

Crystal clear, extra-thick APET sheet should be produced in a relatively dust-free environment, as APET has a propensity for static charges. Otherwise, dust will be “sucked” to the sheet during production and can create scratches. “Dust might seem to be a tiny issue, but all of the measures mentioned above are null and void if the production environment is not relatively free of it,” Rupert Becker concludes.

SML offers a number of different technologies for the production of APET. For extra-thick thermoforming sheet for crystal-clear applications, SML recommends single screw extrusion systems in combination with upstream dehumidifying dryers, where the raw material is pre-treated.

SML Maschinengesellschaft mbH
Gewerbepark Ost 32, 4846 Redlham, Austria
www.sml.at

Optimization Process Parameters for PVC Compounding using a COMPEO Kneader

The excellent mixing capabilities of BUSS Co-Kneaders can be attributed to the unique operating principle which features simultaneous rotation and axial oscillation of the mixing and kneading screw shaft. The oscillating screw shaft ensures intensive material exchange in an axial direction by multiple splitting, folding, and reorientation of the product. This principle is very suitable for many demanding applications, while the flexibility of the compounder offers a series of aspects that can be optimized for PVC compounds.

Following is a description of optimized machine parameters of the COMPEO kneader that contribute to high productivity and optimum quality of the PVC compounds.

- **Optimized intake zone** with back venting and expanded volume intake. Two features were improved: intake length and expanded volume intake section (EVI)
- **Flexible process section** which can be configured using 3-flight or 4-flight technology or a combination of both to optimize the transition/mixing zones
- **Flexible discharge concept** with conical twin screw or single screw in cascade configuration

One area of optimizing the intake zone is the inlet length. If the inlet length is too short, the material intake becomes the bottleneck for the whole process (not sufficient back venting, and fluidization of powder). If the inlet is too long, it will waste process length.

Therefore, the target is to find the optimum length of the inlet opening through different trials with typical PVC grades.

The findings are shown in diagram 1, where the throughput remains unchanged above 2 L/D and is reduced below 2 L/D. So, the ideal inlet length for the COMPEO machine is 2 L/D.

A further aspect of optimizing the inlet zone refers to the optimization of the EVI (expanded volume intake). This EVI can be influenced by the single screw design of the BUSS Kneader as it allows flexible variation of the outer screw diameter and its length. The target is to find optimum EVI parameters.

The first is the ratio between the inner and outer diameter. Thereby the inner diameter remains the same. This influences the free volume by the intake to get the dryblend in. The second variable reviewed is the length of the EVI.

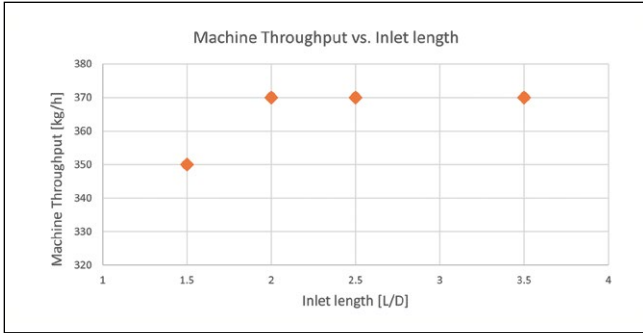

Diagram 1: Throughput as a function of the inlet length

The impact of these two variables was tested and the results are shown in diagram 2. It shows that a longer EVI section increases the throughput by 10 to 20%, while a larger EVI diameter massively increases the throughput by 50%. The overall increase in the throughput compared to the reference is approx. 60 %.

Besides the intake section, an optimized process section was evaluated through adjusted designs of the transition and mixing zones. The designs of configurations of the COMPEO process section using 3-flight- or 4-flight-technology or a combination of both were compared in their impact on temperature rise and specific energy input.

The unequaled flexibility of the combination of these various technologies is a particular advantage of the COMPEO series.

This flexibility also includes the possibility of using two flight elements that operate like dynamic restriction rings cleaned by pins. Due to this principle, the risk of burning is significantly lower compared to using real restriction rings.

The target was to define the optimal transition and mixing zones regarding specific energy input and product conveying. Firstly, different transition zone screw configurations were tested. The findings from these tests are shown in diagram 3.

The use of 4-flight elements (configuration 1) results in very good feeding behavior, and reduced shear input at the end of the feeding zone. Conversely, using

Diagram 3: Temperature trends of different screw configurations

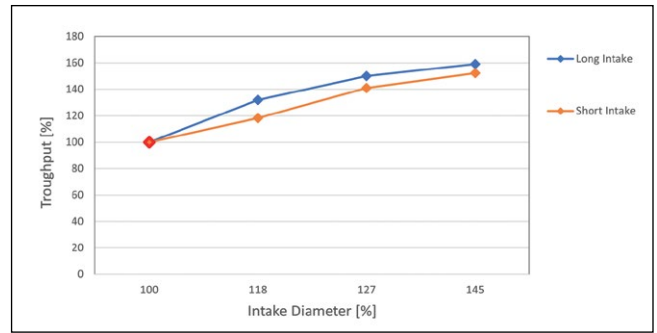
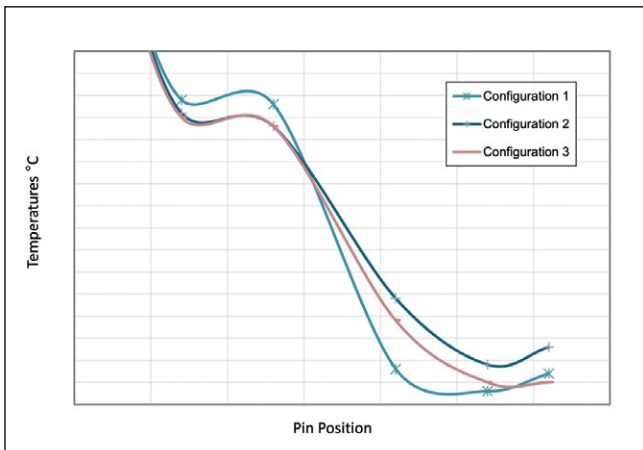

Diagram 2: Influence of the EVI diameter and length on the machine throughput

3-flight elements (configuration 2) shows reduced conveying capacity and increased shear input. The third configuration was a combination of 3- and 4-flight elements that achieved a very good intake behavior, combined with increased specific energy input in the transition zone. The flexible configuration offers superior processing performance.

To optimize the mixing zone performance, different screw configurations were tested. The results are displayed in diagram 4 and the findings are as follows: the use of 3-flight elements with long shearing flanks (configuration 1) results in very high energy input and long residence time. This is not favorable for PVC compounding. In configuration 2 (3-flight elements with short shearing flanks), still a long residence time was observed with a reduction of shear input compared to configuration 1.

In contrast to these previous configurations, the use of 4-flight elements with long shearing flanks (configuration 3) performed optimally in terms of a short residence time together with very high conveying stiffness.

The use of 4-flight elements with short shearing flanks (configuration 4) also showed a short residence time; on the other hand, the conveying stiffness was reduced.

These results reveal the huge potential of this concept to adjust the configuration depending on the product/customer requirements.

Diagram 4: Impact of different flight geometries on the temperature trend

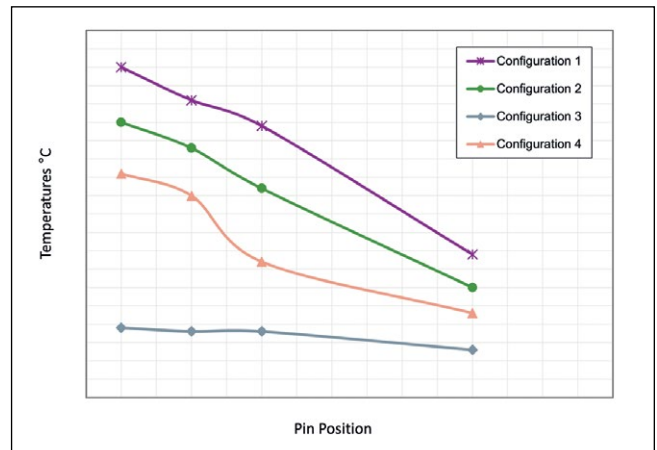

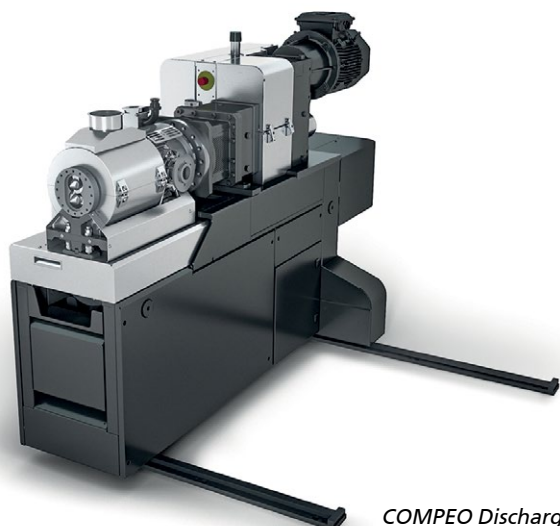

COMPEO Discharge Pump

Besides the intake and the process sections, also on the discharge end of the compounder, there is potential to optimize for PVC compounding. The aim is to produce a wide range of products on the equipment. This can be achieved using the COMPEO Discharge Pump, a conical twin-screw extruder.

A comparison of this discharge pump with a single screw and a melting pump discharge gives insights into the behavior of the various concepts:

Single Screw discharging has some disadvantages as it builds up pressure inappropriately with low viscous materials, has insufficient cleaning, and is lacking conveying capability.

Using a melt pump for discharging results in higher shear rates (gear, bearings), lacks long-term stability from abrasive materials, and is sensitive to damages from powder.

A discharge pump has the consequence of a higher equipment cost. These costs stand against a series of advantages like high pressure build-up, high conveying

efficiency comparable to a gear pump but with gentle conveying without dead zones, no shear peaks, and self-cleaning of the screws. Furthermore, there is an excellent degassing option due to a large surface area.

Based on the above and the experience after several trials, it can be concluded that for standard PVC applications, a single screw discharge usually is sufficient.

A discharge pump is appropriate for special products in the PVC world such as PVC Masterbatches. It also can be used for direct extrusion together with dies for pipes, sheets, and so on.

To summarize the above: the great flexibility and capabilities of the COMPEO kneader offer major advantages in PVC compounding. Optimum quality can be combined with much higher throughputs compared to using traditional set-ups. Complemented with a specially developed discharge pump and the long-standing experience of BUSS in the PVC industry, the COMPEO is ideally suited for solving today's and future PVC compounding requirements.

The author:

Lukas Jenni has an MSc in mechanical engineering and is currently working as a process specialist for BUSS in Pratteln, Switzerland.



Lukas Jenni

Buss AG

Hohenrainstr. 10, CH-4133 Pratteln, Switzerland

<https://busscorp.com/>

First Food Grade R-PET Sheet Production Line to Lithuania

By mating its energy efficient sheet extrusion lines with Kreyenborg's IR-CLEAN Super-Clean process for post-consumer recycled PET, MEAF Machines can now offer its customers a cost effective alternative for the production of FDA/EFSA approved single layer PET food grade sheet. A first R-PET extrusion line combining the two, has recently been installed at Pack Klaipėda UAB in Klaipėda, Lithuania, for the production of meat packaging. The line is also suited for the production of PP trays without alterations, providing the customer with even more flexibility.

Founded some 12 years ago, Pack Klaipėda UAB initially focused on expanded PS containers for take-away food. However, three years

ago the company decided to move into other food packaging, notably for meat and poultry. "We looked at several potential suppliers, but

found MEAF to have the same output at a much smaller footprint than competitors' offerings," says Darius Kontrimas, CTO at Pack Klaipėda.

“Because of rising energy costs, energy efficiency was high on our list and MEAF’s machines are probably best in class when it comes to that. Once we made our decision, we were pleasantly surprised by the level of support we received. Being new in the sheet extrusion business, we had tons of questions. MEAF answered all of them and provided us with all the info we needed and more,” he concludes.

“This new line perfectly fits the current global trend to produce ever more with 100% Post Consumer Recycled (PCR) material such as bottle-flakes and works also with other thermoforming regrind,” says Roald de Bruijne, Sales Manager at MEAF. “However, the process needs to ensure that the cleaning and decontamination is properly done in order to adhere to the strict FDA/EFSA regulations. This requires processors to invest substantially in dedicated equipment to upgrade their sheet production. At MEAF we believe our affordable, energy-efficient and flexible solution allows our customers to make the transition to recycled material more easily.”

Kreyenborg’s IR-CLEAN® is specifically designed as a cost-effective solution for the direct reprocessing

“We found MEAF to have the same output at a much smaller footprint than competitors’ offerings,” says Darius Kontrimas, CTO at Pack Klaipėda (Source: MEAF)



of post-consumer PET flakes for food packaging, combining crystallization and drying in a single process. The system operates without vacuum technology and can be retrofitted on existing extrusion lines. The efficiency of the cleaning process has been verified by a Letter of Non-Objection from the US Food and Drug Administration (FDA), while tests have shown compliance with the European Food Safety Authority (EFSA) criteria for the use of recycled materials for direct food contact packaging.

Roald continues: “At MEAF we already have a good reputation for energy efficient, affordable and flexible extrusion machines. When it comes to the use of R-PET

MEAF Machines has recently installed a first R-PET extrusion line for the production of meat packaging at Pack Klaipėda UAB in Klaipėda, Lithuania (Source: MEAF)

for packaging, bottle-to-bottle is relatively easy as the mechanical properties of the regrind are pretty stable. However, the tray-to-tray recycling process is a lot harder. We are therefore now working hard on the development of a compact unit for IV level increase that can be fully integrated in new and existing extrusion lines. This will further support customers in their transition toward true circularity.”

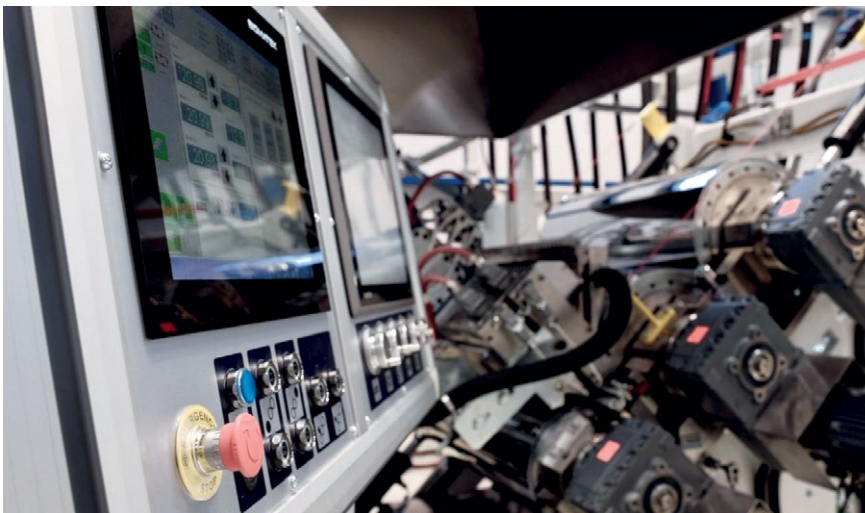

MEAF Machines B.V.
 Industrieweg 10, 4401 LB Yerseke,
 The Netherlands
 → www.meaf.com

With Several Innovations at the wire 2024

SIKORA, manufacturer of innovative measuring, control and sorting technologies, will present the entire range of current, improved and new products for quality control and cost optimization in cable production at wire 2024 in Düsseldorf from April 15 to 19. Visitors can look forward to three world premieres.

"Moving forward": World premiere of new products

At wire 2024, SIKORA will unveil three innovative measuring devices that redefine the segment of measuring technology for cable production lines. The accompanying marketing campaign "Moving forward" underlines SIKORA's commitment to offering its customers future-oriented solutions. The campaign presents the three new systems as a promise of further development and as a statement for progress. "With the new products, we are bringing movement to measuring technology. Our customers can look forward to reliable, future-oriented products that continue to lead the way with their performance and make a significant contribution to increasing productivity and cost efficiency in production," says Katja Giersch, Head of Corporate Communications at SIKORA. Visitors can familiarize themselves with the advantages of the systems live at the exhibition stand.

X-RAY 8000 ADVANCED/NXT: Remarkably efficient in CV lines

In the field of power cable production, the X-RAY 8000 has been providing precise measurements and maximum reliability for over 30 years. These are features that ensure the quality of cables during production and lead to material and cost savings. At wire, SIKORA presents

3 innovative measuring devices celebrate their world premiere at the SIKORA booth. The accompanying marketing campaign presents the systems as an expression of further development and as a statement for progress

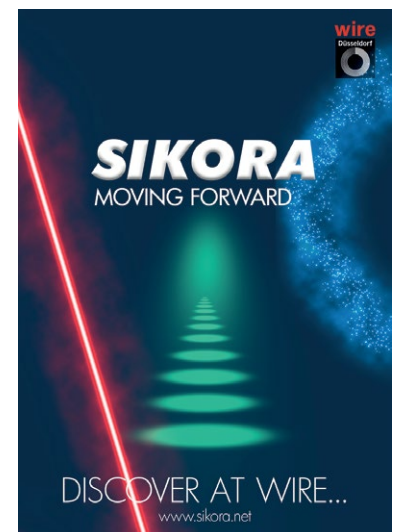

the 3rd generation measuring system based on X-RAY technology, X-RAY 8000 ADVANCED, which measures the wall thickness, eccentricity and diameter of cables in CV lines directly after the crosshead. It therefore provides measuring values for centering and control without delay.

Another highlight is the X-RAY 8700 NXT, which measures the final product dimensions at the end of CV lines, both horizontally and vertically. By using SIKORA measuring systems, both at the beginning and at the end of production, shrinkage values are determined for

The X-RAY 8000 ADVANCED is used in CV lines for the quality control of cables



The X-RAY 6000 PRO measures the wall thickness, eccentricity and diameters of cables in insulating and sheathing lines



all three insulation layers of the cable. This ensures optimum process control for maximum efficiency.

**PURITY SCANNER ADVANCED:
Pure plastic pellets for the insulation
of power cables**

Particularly in the production of high-voltage and submarine cables, it is essential that contamination, which can occur during production, does not enter the insulation of power cables. The PURITY SCANNER ADVANCED uses X-ray technology and optical cameras to detect contaminants such as metal down to 50 µm in the pellet and automatically sorts out impurities. This ensures that only pure material is processed further, minimizing breakdowns, ensuring the quality of the cable and preventing follow-up costs. The function and benefits of the system will be clearly demonstrated at wire using a hybrid exhibit.

**X-RAY 6000 PRO: Fascinating in insulating
and sheathing lines thanks to cost savings**

With the X-RAY 6000 PRO, SIKORA introduces another member of the X-ray system family. This system continuously provides measuring data on wall thickness, eccentricity and diameter in insulating and sheathing lines. These are clearly displayed on the monitor of the ECOCONTROL 6000 processor system. The X-RAY 6000 PRO can be used either after the extruder, between two cooling sections or at the end of the line for cold measurement. From the first day of commissioning, the system enables the wall thickness to be reduced to the smallest permissible value. This results in significant material and cost savings for the user.

**FIBER Series 6000: Distinctive measuring
rate for optimum tension measurement**

SIKORA's gauge head models of the FIBER Series 6000 promise the highest performance and fiber quality. From the measurement of diameter, fiber position, vibration frequency, temperature and spinning to the detection of airlines and lumps, the innovative measuring devices monitor and control the entire drawing process. The improved measuring rate of the FIBER TENSION 6003 of up to 50 kHz enables optimum tension measurement. This makes the measuring head particularly

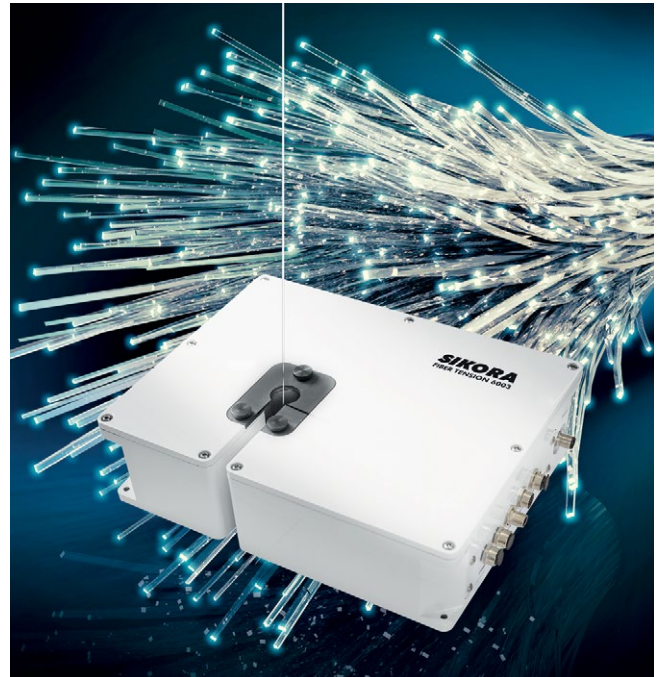

The FIBER TENSION is used in the drawing tower for tension measurement

suitable for optical fibers that are further processed into premium optical fibers. Visitors to wire will be able to see the performance of the measuring heads live in the drawing tower.

**Service To Perfection: For reliability and availability
of SIKORA systems**

When it comes to the reliability and availability of SIKORA systems in the production line, the SIKORA service team in Bremen and worldwide subsidiaries are always there for their customers. At wire, SIKORA presents the entirety of its service portfolio. From the installation and commissioning of the devices to consulting and training, always tailored to individual customer requirements.

SIKORA AG
Bruchweide 2, 28307 Bremen, Germany
➔ www.sikora.net

wire 2024:
Hall 9, booth A41

Quality is our Priority

As a market-leading company for adjustable calibration sleeves, CCA cares for the automation of plastic pipe production with long-term experience and know-how.

Each calibration sleeve is developed to precisely match the individual production requirements. This means state-of-the-art technology backed by more than 30 years of experience. The results: increased product quality and cost-effectiveness.

Innovation is our Passion

CCA stands for reliable, high-performance solutions – for pipe diameters of 14 up to 2400 mm (inch sizes available). The five different sleeve systems have one thing in common: an adjustment without maintenance-intensive adjustment gears.

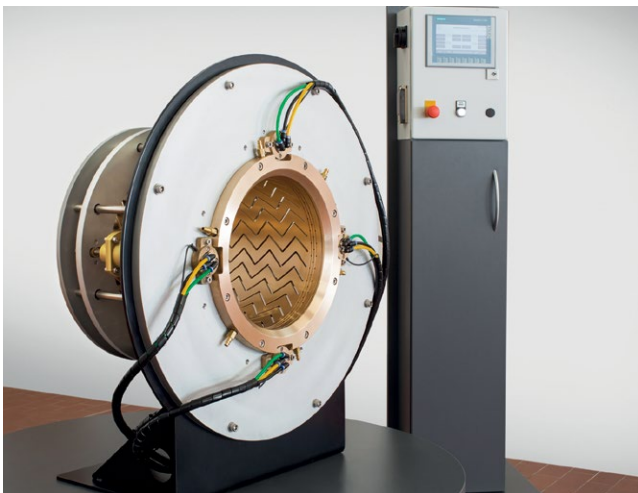

CCA GmbH
Werkstr. 10, 32584 Löhne, Germany
www.ccagmbh.de

Motor-controlled calibration sleeve for inline control of the diameter and ovality of the pipe. Starting from an outside diameter of 280 mm to 2400 mm (also available in inch sizes)

System Overview Conventional Calibration Sleeve

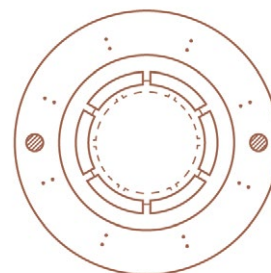
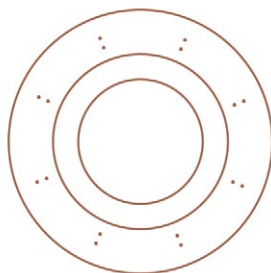

*Adjustable Calibration Sleeve
Two-Point Adjustment*

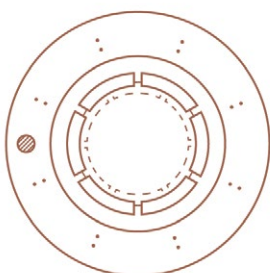

*Adjustable Calibration Sleeve
One-Point Adjustment*

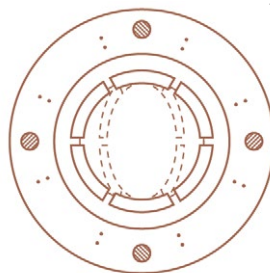

*Adjustable Calibration Sleeve
Four-Point Adjustment*

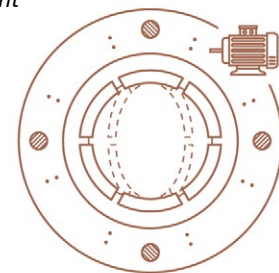

*Motor Controlled
One-, Two- or Four-Point Adjustment*

BOOST YOUR EXTRUSION



To achieve perfection and continuous improvement, Tecnomatic chooses maximum specialization and concentrates its efforts on the development of

extrusion lines for the production of polyolefin pipes with diameter up to 3 000 mm. Technical knowledge, constant research and great passion allow Tecnomatic to offer

high-performance solutions fulfilling all possible customer requirements since 1977.



TECNOMATIC

TECHNOLOGIES FOR PLASTIC PIPES PROCESSING

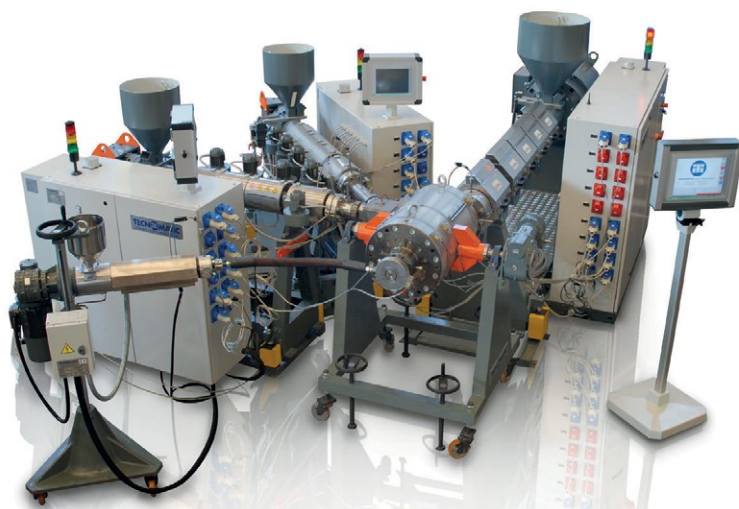

Tecnomatic Srl | Bergamo | Italy | tel. +39 035 310375 | tecnomaticsr.com

PET Bottle Life Cycle and NIR Heating Technology

The global PET containers market is expected to grow annually at 5.3% CAGR between 2022 and 2023. It will increase from USD 73,1Bn to USD 122,4 Bn, according to the Future Marketing Insights report. More than 500 billion PET bottles are used globally to pack different products. Unlike other types of plastic, PET is 100% recyclable.

NIR radiation is applied to various stages of PET bottle lifecycle: from pallets and preform injection to bottle blow molding and its recycling. The global trend to switch to rPET contributes to it. We will see why.

IR radiation & thermoplastic polymers

PET, or plastic #1 according to recycling symbol, is a thermoplastic polymer belonging to the polyester group. It is fully recyclable and widely used to produce bottles for beverages and jars for food, containers for vegetable oil and vinegar, household chemicals and cosmetics.

Polyethylene terephthalate is often recycled into fibers, sheets, fabrics and definitely in new PET packaging. In natural state, the resin is colorless, semi-crystalline, highly flexible. Once processed, it can be semi-rigid and rigid.

Being thermoplastic polymer, heat impact leads to its softening and deformation. In bottle manufacturing, a PET preform once heated and passed to the mold, takes the shape of the latter. Thus, it is difficult to overestimate the importance of the heating system of reheat PET stretch blow molding machine and lamps in particular.

Infrared lamps emit a wide range of frequencies. There are 3 types of infrared radiation:

- Wave number near infrared with frequencies of 2500-714 nm ($4000-14,000\text{ cm}^{-1}$)
- Wave number mid infrared with frequencies of 25 000-2500 nm ($400-4000\text{ cm}^{-1}$)
- Wave number far infrared with frequencies of 2 500 000-25000 nm ($4-400\text{ cm}^{-1}$)

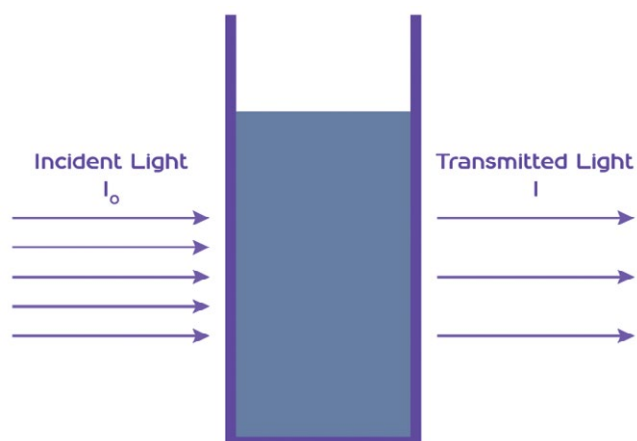

NIR lamps & bottle blow molding

Different wavelengths interact with different compounds in different ways. Each type is defined either by the source of light to trigger an interaction between constituent wavelengths and compounds present in the sample, or the electromagnetic spectrum field analyzed. IR and NIR Spectroscopy both fall into the latter category.

Both IR and NIR Spectroscopy use spectral data to characterize matter. The main difference is the field of the electromagnetic spectrum studied. NIR Spectroscopy focuses on the 714 nm to 2500 nm range. This is just outside the range normally visible to the naked eye.

Found in the 19th century, the near infrared energy found its industrial application only in the mid-20s century. It was used as add-on unit for other optical devices. In the 21st century its application expanded to PET stretch blow molding. PET Technologies is among the leaders in the field.

Near infrared radiation perfectly penetrates PET and reheats PET preforms. In fact, the radiation in the NIR range can penetrate the PET samples completely to a depth. Beer-Lambert Law is the main principle and the basis for the different methods of spectrophotometry, including NIR spectroscopy. According to it, the amount of light absorbed by a sample (in this case, it is PET preform) is directly related to the volume of sample the light passes through and the concentration of the sample.

The importance of NIR technology is difficult to overestimate for manufacturing of such PET bottles as:

- Asymmetric bottles;

- Refillable / returnable bottles;
- Hot fill bottles;
- Cylindrical bottles at high speed;
- Color PET bottles

The heating process is faster in comparison with the conventional infrared (IR) system. It reduces energy consumption and permits to design a smaller (shorter) heater of the PET stretch blow-molding machine. The equipment has smaller footprint and is easier to transport.

Case study

PET Technologies with 24 years of experience in the industry was among the first companies that adapted NIR heating to the linear PET stretch blow molding machines. The innovative series of blow molders APF-Max is among the first SBM machines of linear type where it was implemented.

It is compact and has a user-friendly concept. The machine has high output while its dimensions are more compact.

The advantages of NIR heating system for PET bottles production:

- Uniform temperature distribution between the inner and outer parts of preform wall;
- Reduced heating time;
- Compact heater size;
- Reduced energy consumption of blow molder.

Automatic temperature regulation is on the top of the story.

NIR radiation & recycling

There is a range of controversies regarding the use of colored (of any other color but for transparent and transparent blue) PET bottles. They have been banned by law in India and South Korea. There are similar discussions in other countries.

In contrast, the European PET Bottle Platform Technical Committee states that transparent colored PET bottles should not be banned. They increase the total value of PET bottle recycling.



Near Infrared (NIR), in combination with optical sorting, is an efficient and quick way to sort PET bottles automatically by color. Once sorted they are 100% recyclable and reusable for different applications. Additional sorting by individual color (e.g., green or amber) is also possible. It additionally increases the rPET value.

NIR & rPET

Finally, this recycled PET bottle is used again to produce a new PET bottle. This can repeat unlimited number of times. They are both eco-friendly and transparent, resistible and flexible. Recycled PET uses 79% fewer greenhouse emissions and less energy than the virgin one.

Some other environmental benefits it has:

- Up 50% less energy is consumed for its production;
- Eliminates plastics wastes;
- Less water is used for production.

Still, not all blow molding machines are capable to process preform from rPET due to the technical limitations. They come from the properties and characteristics of the material. Some of the reasons why not all machines are capable to process it:

- Material properties (melt flow, crystallinity, molecular weight);
- Wear and tear (rPET contains impurities that cause additional wear of blow molding machine components);
- Melt temperature and thermal stability (rPET requires higher processing temperature due to its molecular changes during recycling).

The whole model range of the reheat stretch blow molding machines developed by PET Technologies is compatible with rPET. Already implemented projects in Europe and Asia, Africa, North and Latin America are a proof.

The role of NIR heating system in bottles blow molding from rPET preform increases with the percentage of recycled content in the sample.

Indonesia's Packaging and Automotive Sectors Spur Demand for Plastics

The industrial sector of Indonesia has been contributing to its overall economic growth, regardless of the upward momentum of its production in terms of volume and value in the past few years. Government incentives to investors, favorable business environment, significant improvement in technologies and skilled manpower are among the factors that encourage the expansion of industrial sector. In particular, the plastics industry in Indonesia is exhibiting sustained growth in the next few years owing to rising demand spurred by increase in consumer expenditure.

With its huge population of 277 million, Indonesia has become an attractive consumer market and given the fast-paced changing lifestyles of buyers with higher disposable income, manufacturers are focused on meeting the requirements by building their production capabilities. Indonesia's plastics market size was valued at US\$8.63 billion in 2022 and is likely to reach US\$ 14.58 billion by 2031, expanding at a CAGR of 6% during the forecast period 2023–2031, according to the projection by Growth Market Reports. Several important industries are crucial to Indonesia's plastics industry – packaging, automotive and medical are experiencing rapid development.

Indonesia's packaging industry remains the major application of plastics. A report of Global Data states that the country's packaging market size, valued at 151.3 billion units in 2022, is poised to register



Indonesia's huge population of 277 million has become an attractive consumer market with huge demand for consumer products (Image: Tom Fisk/Pexels)

a CAGR of more than 3% during the period 2022 to 2027 with flexible packaging segment dominating the market share until 2027.

From a linear model, Indonesia's packaging industry is fast moving towards a circular economy. This has been made more pronounced by the investments of leading companies into areas that will reduce, recycle and re-use plastics. As an economy battling huge plastic waste stockpile reaching 18.99 million tons per year based on Environment and Forestry Ministry data, Indonesia has placed circular economy as its main focus by implementing Golden Indonesia Vision 2045 which is the long-term national development plan. Thus, the utilization of recycled materials has become the goal of many Indonesian companies that plan to go through the route of circular economy route. This has brought huge opportunities to companies supplying advanced recycling solutions and sustainable

materials. This has also opened new horizons to both Indonesian and foreign companies operating in Indonesia that a number of significant ventures into plastics manufacturing has been launched in the country's various industrial centers.

Coca-Cola in Indonesia has launched its new packaging made by 100% recycled PET (rPET), excluding caps and labels, in line with the vision of World Without Waste. Coca-Cola operates a recycling plant, Amandina Bumi Nusantara, located in Cikarang. The recycling



Coca-Cola Indonesia launched new packaging made by 100% recycled PET (rPET), excluding caps and labels, in line with its vision of World Without Waste (Image: Coca-Cola Indonesia)



Pan Era Group and Milliken in partnership to promote circular economy in Indonesia (Image: Pan Era Group)

plant, with capacity of 25,000 tons of PET per year, is a partnership between Coca-Cola Europacific Partners Indonesia and Dynapack Asia. The production of bottles with 100% rPET content aims to accelerate the goal of reducing the use of conventional plastics and lowering carbon emissions.

Indonesia has gained the importance as an automotive center in the region with a growing number of companies engaged in this sector that are setting up their operations in the country. The country's automotive companies are increasingly becoming focused on launching electric vehicles, and along with meeting trends such as lightweighting and enhanced safety and autonomy, bringing the dramatic demand for automotive plastics. Engineering plastics for the automotive industry are predominantly imported, but an increasing number of local manufacturers are improving their portfolio through partnership with foreign companies. It has been estimated that Indonesia's automotive industry players will need around 200,000 tons of plastics yearly with less than half supplied by domestic companies. The bright prospects for plastics in Indonesia's au-



Wuling Motors Indonesia launched the Wuling Bingo EV, its second electric vehicle (EV) model (Image: Wuling Motors Indonesia)

tomotive will be sustained by major foreign and domestic players. Investments into Indonesia's automotive industry have been on the rise, attracted by the large consumer base and excellent infrastructure.

At CHINAPLAS 2024, Indonesian plastics manufacturers will witness a full range of new materials and high-tech processes to enable them to further enhance their production efficiency and profitability in the wake of fast-changing consumer preferences. The mega exhibition highlights the most advanced packaging technologies and environmental friendly materials to support the move towards a circular economy. A broad range of machinery, equipment and engineering plastics is also on exhibit to promote the development of the automotive industry. For more information, visit:

► www.ChinaplasOnline.com

CHINAPLAS 2024:
Shanghai, P.R. China,
April 23 to 26, 2024

Process Automation and Control of Extrusion Lines

For over 40 years, iNOEX has been a trusted solution provider of innovative, high-quality measurement technology in the plastics industry. The intelligent, user-friendly systems bring lasting added value to extrusion processes.

Many of today's manufacturing sectors face increasingly complex challenges that can influence their success. The iNOEX products are designed for a wide range of pipe, tube, cable, and profile extrusion applications, serving as comprehensive solutions for process automation.

In addition to global supply chain issues and the overall economic climate, the challenges like long-term competi-

tiveness, high standards for product quality, rising material costs, shortage of skilled labour or production environment digitization are particularly relevant to much of the plastics processing industry today and therefore also to the production of pipes, tubes, and cables.

Finding solutions to these challenges requires the ability to react quickly to changes in the market and, at the



WARP – radar system

same time, meet the highest standards when it comes to product quality, accuracy, and documentation. This requires precise wall/layer thickness distribution data, compliance with limit values for ovality and eccentricity, the ability to easily adjust varying product parameters, and robust and durable system components.

Improving efficiency and achieving the highest level of accuracy is not possible without systematic process automation.

The demand for high-quality products yet the shortage of skilled workers has created a major challenge for many branches of industry. In combination with the gravimetric systems, the measuring systems from iNOEX offer various control options to ensure consistently high product quality. The data collected for process improvement and quality control create the data pool used for automation.

This holistic approach makes us a solution provider for the plastics industry. Manufacturers benefit from increased material savings of up to 5% and drastically lower quality assurance and documentation costs, resulting in a quick return on investment. At a time when there is a growing shortage of skilled labor, plant managers are no longer solely dependent on specific plant operators with many years of experience.

SAVEOMAT gravimetric dosing

The SAVOMAT product line measures, controls, and doses a wide range of raw materials with the highest level of precision. It is suitable for both mono- and co-extrusion and can be seamlessly integrated into production lines, serving as the foundation for a customized

*Jan Lohoff,
CEO iNOEX Group:
„Our broad and innovative
product portfolio enables
us to respond flexibly
to market challenges.
This is why we are a solution
provider for the pipe,
cable, profile and film
extrusion industry.“*



process automation approach. From pipes and films to cables and profiles, these systems are designed for a variety of applications and ensure consistent quality in each stage of the production process.

AUREX ultrasonic measuring system

The intelligent AUREX ultrasonic systems not only reliably measure pipe diameter, wall thickness, ovality, and eccentricity with precision. Defect detection is also available as an option. The result is higher quality single- and multi-layer pipes and cables. When combined with the SAVEOMAT gravimetric systems, the entire process can be completely automated.

WARP radar-based measuring system

WARP radar measuring systems provide precise, non-contact measurement with automatic centering



and (optional) 100% pipe coverage. This inline system is specifically designed to measure smooth walled and corrugated pipes to give maximum flexibility. Thanks to advanced chip technology, our WARP systems are reliably accurate and efficient.

iXRAY X-ray measuring system

The non-contact iXRAY X-ray technology measures the diameter and wall thickness of single and multi-layer pipes and hoses with precision. The advanced 3-axis technology measures twice the number of points of a 2-axis system, resulting in improved ovality detection. These systems are versatile and perfectly suited for aluminum multilayer pipes, fabric-reinforced pressure hoses, pipes, and cables.

One of the main challenges many manufacturers face today is fulfilling increasingly complex product and quality control requirements while at the same time experiencing a shortage of labor. Improving efficiency and achieving the highest level of accuracy is not possible without systematic process automation.

As a solution provider for pipe extrusion, automation is therefore guiding principle from iNOEX. Combining gravimetry with a measuring system and control technology is the key to increasing productivity, significantly reducing costs, and at the same time ensuring the highest level of quality possible. Furthermore, when raw materials are used efficiently, you move closer to achieving the sustainability goals and securing the competitive advantage for the future.

Gravimetry

Every raw material is subject to fluctuations in bulk density. Gravimetric weighing allows fluctuations in mass throughput to be recorded and automatically balanced out. In principle, gravimetry offers two control options: mass throughput control and meter weight control.

Mass throughput control: The extruder speed is adjusted to the material feed into the extruder.

Weight per meter control: The haul-off speed is controlled based on the amount of material fed into the extruder. This keeps the weight per meter constant and eliminates fluctuations in wall thickness in the direction of extrusion. The smaller fluctuations also reduce the target wall thickness, saving material.



SAVEOMAT – gravimetric system



AUREX – ultrasonic system

Measuring system

The wall thickness measuring system is integrated into the production line and offers additional control options during the extrusion process. The system measures important parameters such as diameter, wall thickness, ovality, and eccentricity.

Thin point control: This is where the pipe or tube is first measured. The thinnest point defines the control section. The control system then calculates the new target value for the weight per meter and adjusts the haul-off speed, which also changes the wall thickness.

As a result, the system records fluctuations in mass throughput and wall thickness so adjustments can be made. This ensures a further reduction in weight per meter. Wall thicknesses are significantly reduced while the minimum wall thickness is maintained.

Further control options

Thermal die head centering for PVC pipes helps save material. The measurement data from the measuring system can be used as a starting point for manual pipe centering. The wall thickness distribution and pipe geometry are recorded by the measuring system and temperature adjustments are then made according to the optimum wall thickness and pipe geometry. New target values are defined and set for the temperature zones. The resulting change in melting speed in the heating zone reduces eccentricity. This leads to a further reduction in the weight per meter and optimal end products.

Gear Pumps Enable Extrusion Industry to Meet Growing Sustainability Demands

Gear pumps are a proven off-the-shelf technology that can bring significant sustainability benefits, helping processors reduce their carbon footprint while improving efficiency and productivity, according to PSI-Polymer Systems. A company's carbon footprint runs deep and includes everything from the production and transportation of the raw materials to in-plant storage and material conveying, to energy used to convert the raw materials to an end-product. In many cases, processors seeking to reduce their carbon footprint can use readily available technologies to reduce energy and material consumption.

"As processors struggle to meet to-day's sustainability demands, the gear pump has emerged as an eco-friendly, go-to solution proven to reduce overall energy load for the extrusion line while simultaneously minimizing the amount of material required for the product," said Don Macnamara, general manager of PSI-Polymer Systems Inc. "This allows for 100% use of regrind without compromising output consistency and minimizing scrap from start-up or off-spec dimensions. Plastics are not going to go away, and it falls to us as industry participants to produce more responsibly. The gear pump helps get us there."

By taking over the pressure-generating function for the die, the gear pump allows the extruder to process the same, or often more volume at a lower RPM. This translates to less energy required to produce a specific volume of output. While this energy amount is arguably small, it adds up, says Macnamara. Consider an extruder running at 100 RPM, 24 hours/day, 5 days/week, 50 weeks/year. That equates to 36 million RPM/year and a gain in yield of 10% to 25% at a lower RPM and a drop in corresponding extruder amps which significantly helps the product's energy footprint.

Another eco-benefit of lowering the head pressure is reducing the extruder motor load, leading to significant long-term energy savings. Lower head pressure also minimizes wear and tear on the screw and barrel. Also reduced is the load on the thrust bearing and drivetrain, which boosts the B10 life of the bearing and reduces the need for gearbox rebuilds. Lower wear leads to fewer rebuilds, each with its additive carbon footprint. For this reason, PSI says many OEMs specify large gear pumps for high-pressure applications to take the load off the extruder.

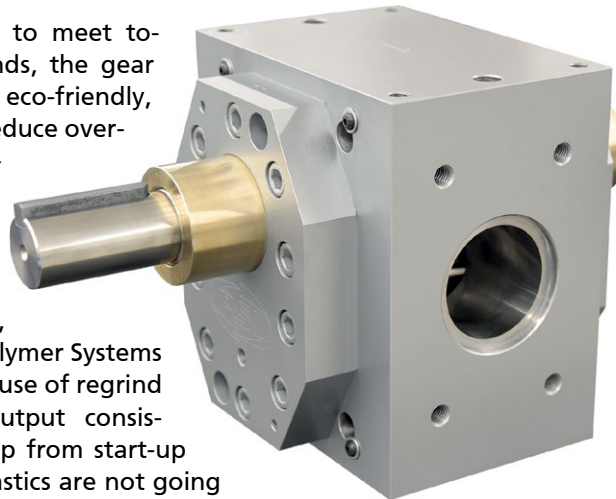

Today's focus on sustainability also involves the inclusion of reclaim, according to PSI. Many processors limit the percentage of regrind in the extruder due to pressure surge which results from variable feed and melt rates of the differing feedstock bulk densities. The tight clearances in the gear pump effectively dampen the extruder surge at the pump inlet by up to 50:1. In many cases, this results in die pressure control of +/- .25%. Consistent die pressure holds wall/gauge variation within a tight tolerance. Running true to the lower end of the dimensional specification eliminates scrap caused by out-of-spec production (over/under).

Cutting scrap saves energy by producing the product once and avoiding the energy impact of reprocessing. Running a tighter tolerance also means using less polymer per product length. For example, one conduit producer extruding 1.5" SDR 13.5 pipe had an average weight of 151 grams per length. Adding a gear pump minimized the overage and resulted in a constant weight per length of 145 grams. At 65 ft/min, 20 hours/day, 5 days/week and 50 days/year, the 6-gram savings eliminated 257,940 lb from the product footprint. That is roughly one million pounds taken out of production in four years while consistently making high-quality pipe.

PSI also notes that a gear pump can reduce the demand for additional cooling during the extrusion process by reducing backpressure-induced shear heating. This can lead to further energy savings by reducing the load on the cooling system.

SMART EXTRUSION

**THE SPECIALIZED WEBPORTAL
ON EXTRUSION
FOR EVERY MODERN NEED**



VM Verlag GmbH
Cologne, Germany



www.smart-extrusion.com

WE ARE FAST WE ARE FIMIC

WE MAKE THINGS HAPPEN

MEET US AT

NPE2024

May 6-10, 2024

The Plastics Show

Orlando, Florida

Booth W5089 - Level 2



www.fimic.it

FIMIC
ITALIAN MELT FILTER